

Remote Sensing and GIS for Stormwater Management

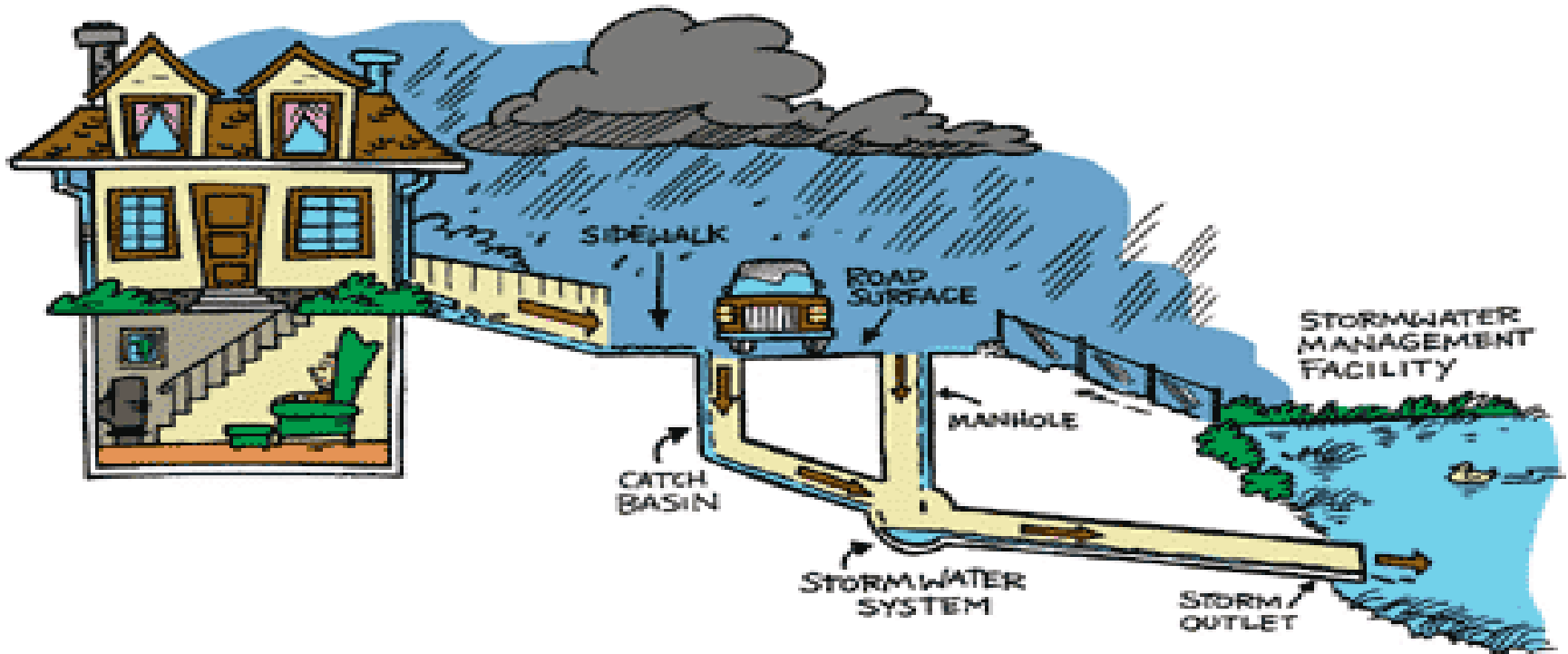

Dr. L N Thakural, Scientist
National Institute of Hydrology, Roorkee

Two major issues: Stormwater Management

- Runoff generated
- Water Quality



Factors affecting quantity of storm water

- ▶ Area of catchment
- ▶ Slope and shape of the catchment
- ▶ Porosity of soil
- ▶ Obstruction in the flow of water as trees, fields, gardens etc.
- ▶ Initial state of catchment area with respect to wetness
- ▶ Intensity and duration of rainfall
- ▶ Atmospheric temperature and humidity
- ▶ Number and size of ditches present in the area



For Effective Water Management

- ▶ Near real time hydrological information
- ▶ Temporal information: *Seasonal Variation*
- ▶ Spatial information: *Point v/s spatial*
- ▶ Synopticity: *think globally and act locally*



Data

- ▶ What form ??? Images
- ▶ Where from ??? Remote Sensing
- ▶ How ??? Airborne/Satellites



Remote Sensing provides



- ▶ Near real time hydrological information: within few hours to few days
- ▶ Temporal : 30 minutes to few days
- ▶ Spatial information : 1m to few km
- ▶ Synoptic coverage : 25 km to 800 km or more

GIS helps to

- ▶ Develop spatial database
- ▶ Integrate databases (RS, Topographic, socio-economic etc

- ▶ Develop WRM strategies



*Remote Sensing
and
Geographical Information System*

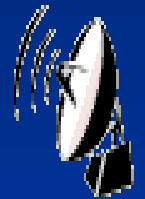



What is Remote Sensing?

Remote sensing is defined as the science and art of acquiring information about objects from measurements made at a distance without any physical contact with the objects.

Measurements in Remote Sensing : reflectance/emittance (EMR)

Sophisticated Instrument used : Sensors



[Camera, MSS, Radar]

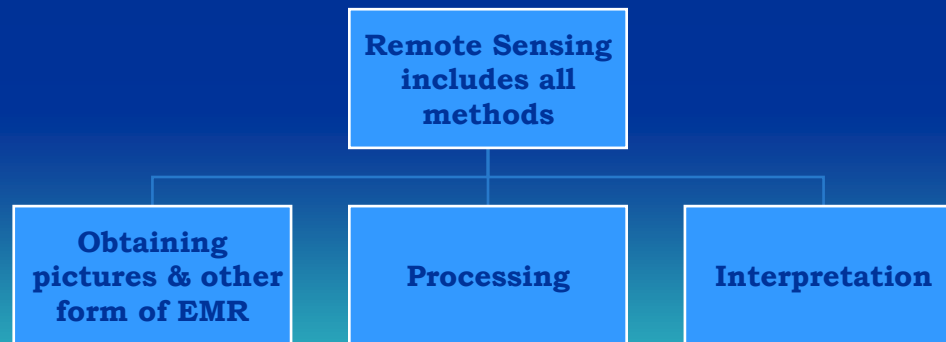



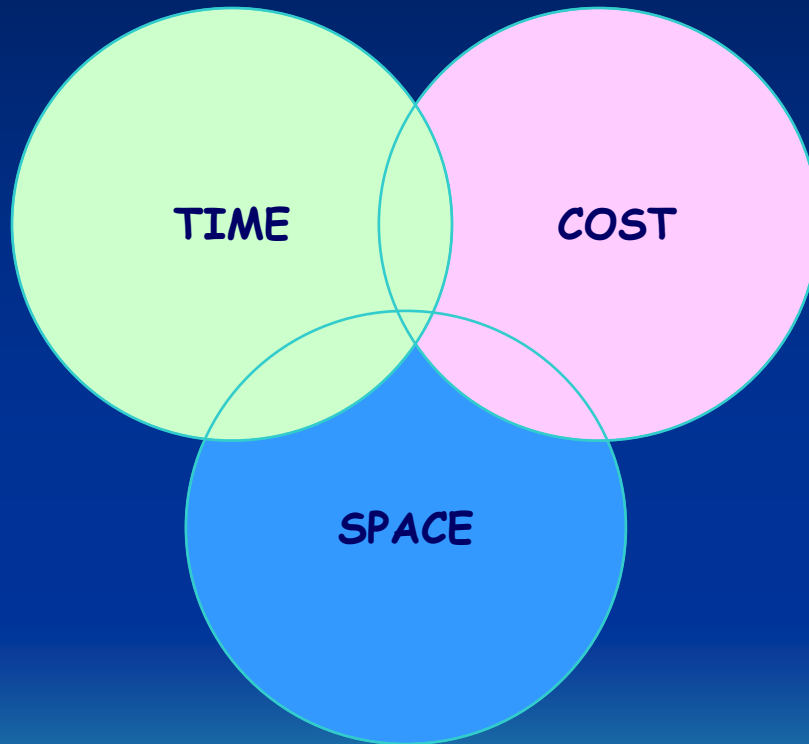

Why Remote Sensing?



**Integration of Spatial
Information for Resource
Management**

Satellite imagery offers a advantages over conventional survey techniques

-  areal synoptic coverage (gives areal information as against point information through conventional techniques)
-  repetitive global coverage (for monitoring change)
-  real-time processing
-  sensing of surrogates rather than the desired specific observation
-  multispectral coverage

Ideal Remote Sensing System

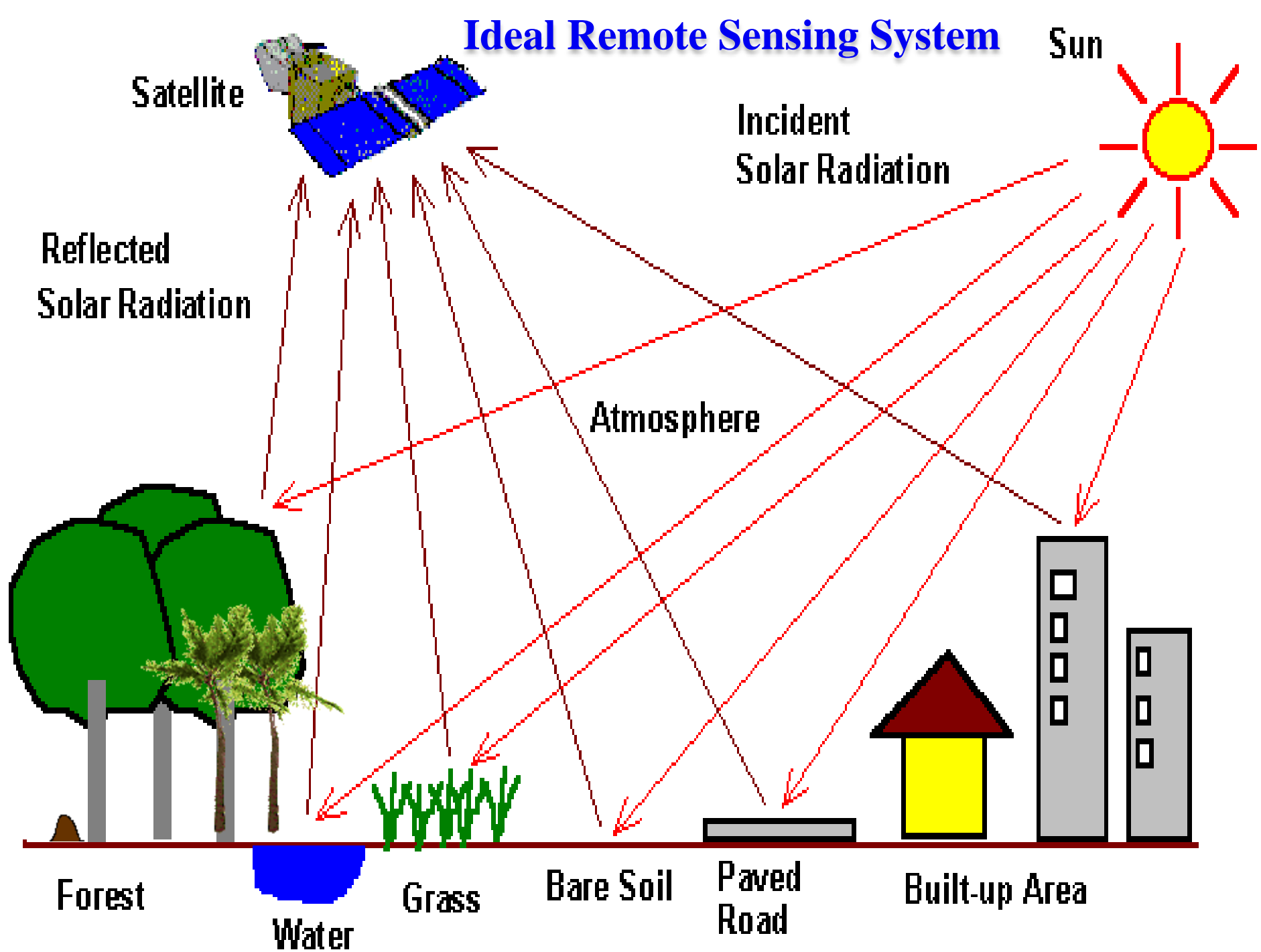

Electromagnetic Spectrum

- ❖ We are mainly concerned with the visible, infrared, and microwave portions of the spectrum

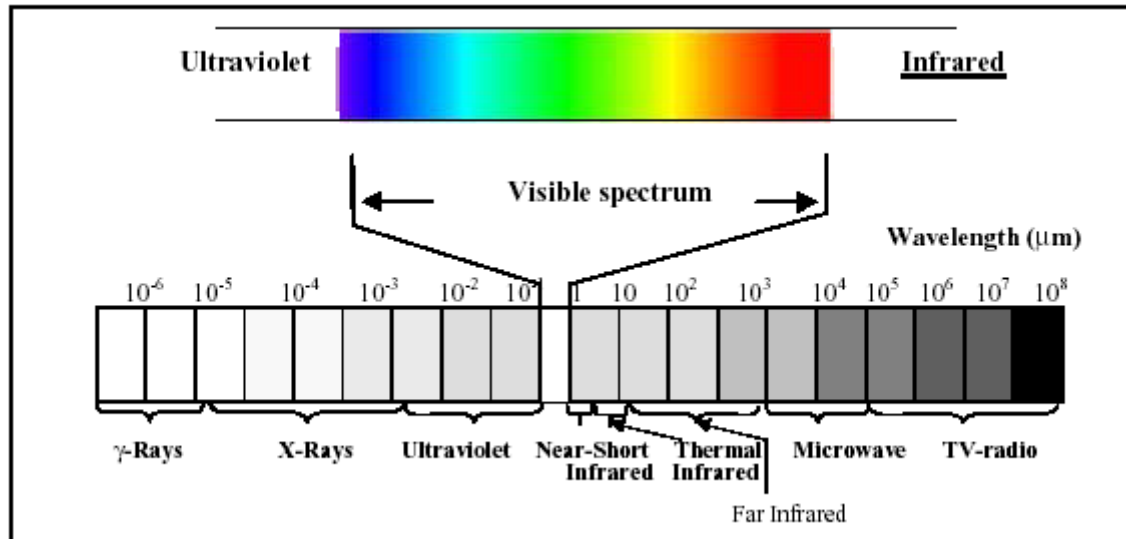

► (Ranges from very short wavelength to long wavelength)

The data collected by the sensors are in the form of electromagnetic energy (EM).

When Electromagnetic Energy (i.e. light from the sun) interacts with objects on the Earth?

- **Reflection**: colour seen is reflected, colours not seen are absorbed
- **Absorption**: when object is heated, absorbs energy
- **Transmission**: energy passes through object
- **Emission**: heat felt from hot object

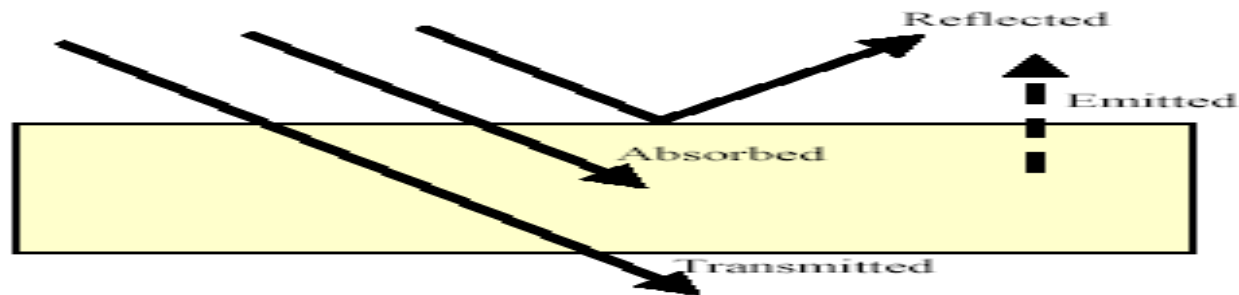
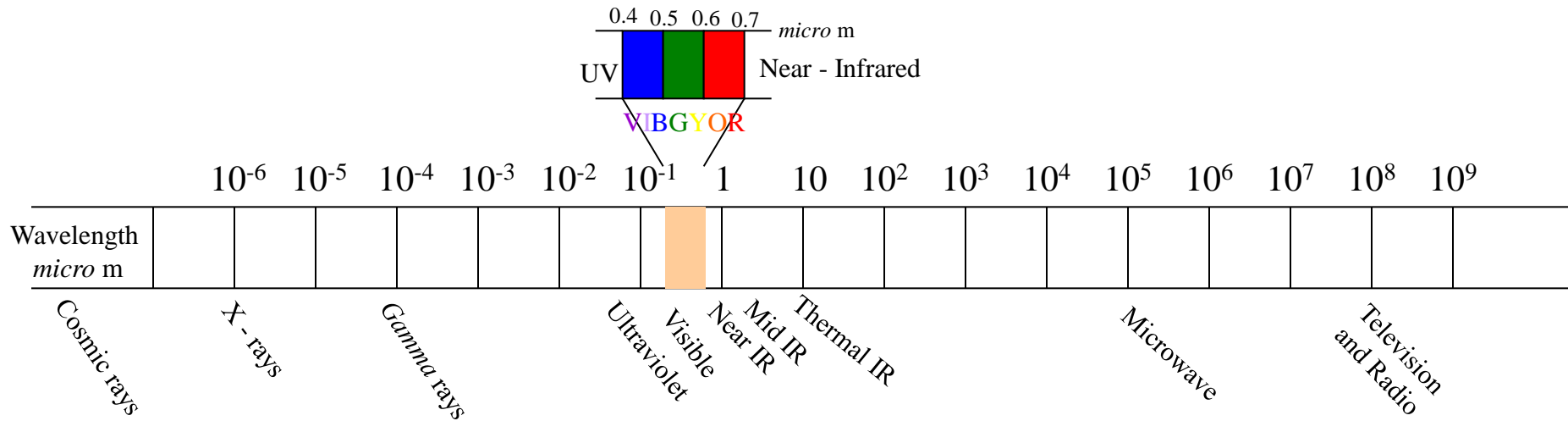

Figure 2-17. Radiation striking a target is reflected, absorbed, or transmitted through the medium. Radiation is also emitted from ground targets.

Electromagnetic Spectrum



Bands refers to spectral channels in the electromagnetic spectrum.

Band	Wavelength (<i>micro m</i>)	Nominal Spectral Location	Principal Application
1	0.45 - 0.52	Blue	Coastal water mapping, soil / vegetation,
2	0.52 - 0.62	Green	Vegetation discrimination, CF.
3	0.62- 0.69	Red	Chlorophyll absorption region, CF.
4	0.76 - 0.90	Near IR	Vegetation, water body, soil moisture
5	1.55 - 2.35	Mid IR	Moisture content, Snow and Cloud, Mineral and rock discrimination, vegetation moisture content
6	10.4 - 12.5	Thermal IR	Vegetation, Soil moisture discrimination
7	1 cm – 1m	Microwave	Soil moisture

SPECTRAL RESPONSE OF SOME NATURAL EARTH SURFACE FEATURES

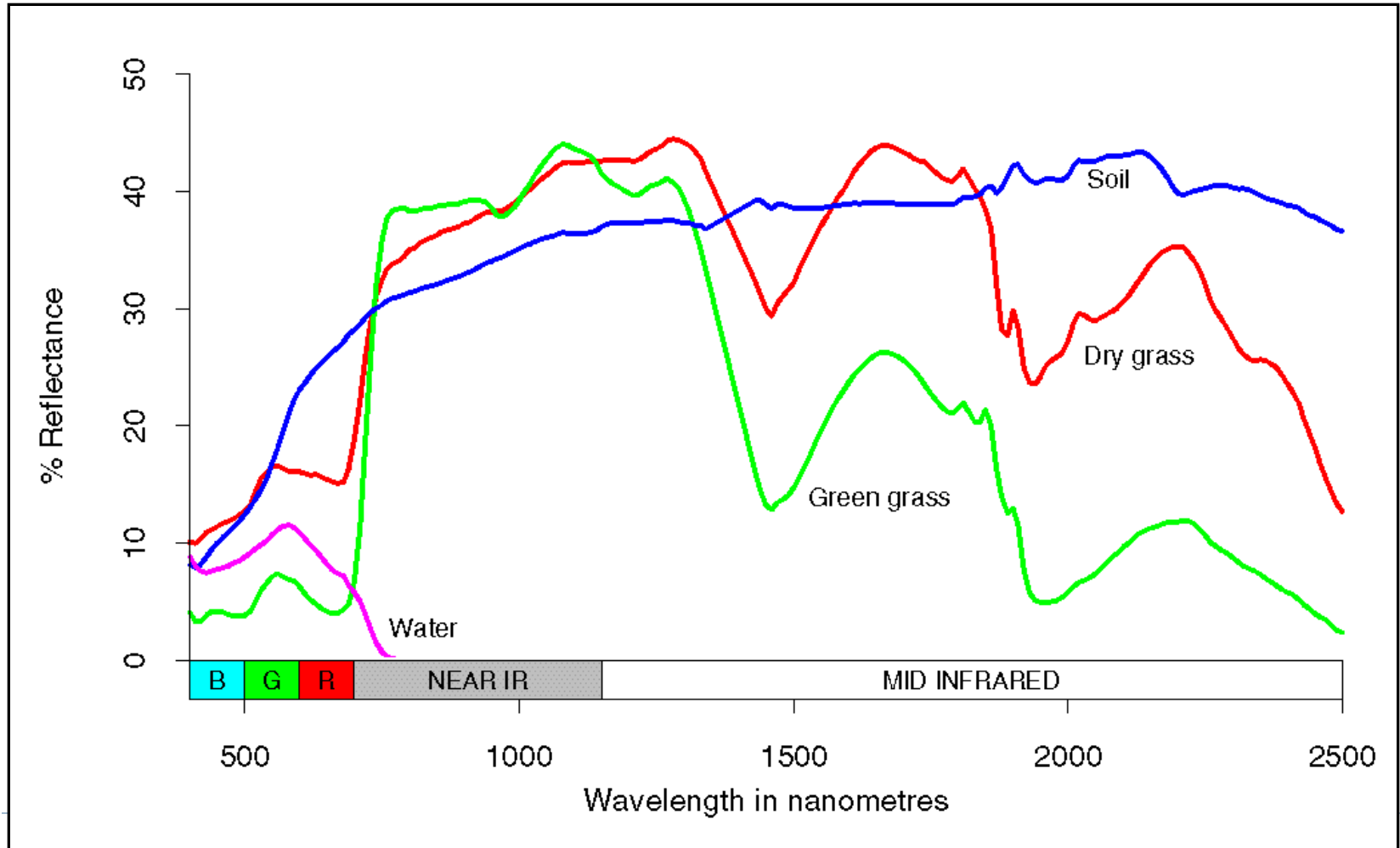

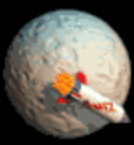

Remote Sensing Applications for different spectral bands

Spectral Band (m)	Applications
Blue (0.45-0.50)	Water penetration, land use, vegetation chta, sediment.
Green (0.50-0.60)	Green reflectance of healthy vegetation.
Red (0.60-0.70)	Vegetation discrimination because of red chlorophyll absorption.
Panchromatic (0.50-0.75)	Mapping, land use, stereo pairs.
Reflective Infrared (0.75-0.90)	Biomass, crop identification, soil-crop, land water boundaries.
Mid-infrared (1.5-1.75)	Plant turgidity, droughts, clouds, snow ice discrimination.
Mid-infrared (2.0-2.35)	Geology, rock formations.
Thermal infrared (10-12.5)	Relative temperature, thermal discharges, vegetation classification, moisture studies, thermal inertia.
Microwave-short wave (0.1-5 cm)	Snow cover, depth, vegetation water content
Microwave –long wave (5-24 cm)	Melting snow, soil moisture, water, water-land boundaries, penetrate vegetation



PLATFORMS AND SENSORS



Platforms and Sensors

- **Sensors**= a device that records **EM Energy**
- **Platforms**= carrier bed used to **carry a sensor**
- **Sensors** and **platforms** that are used to **create image data** of the Earth

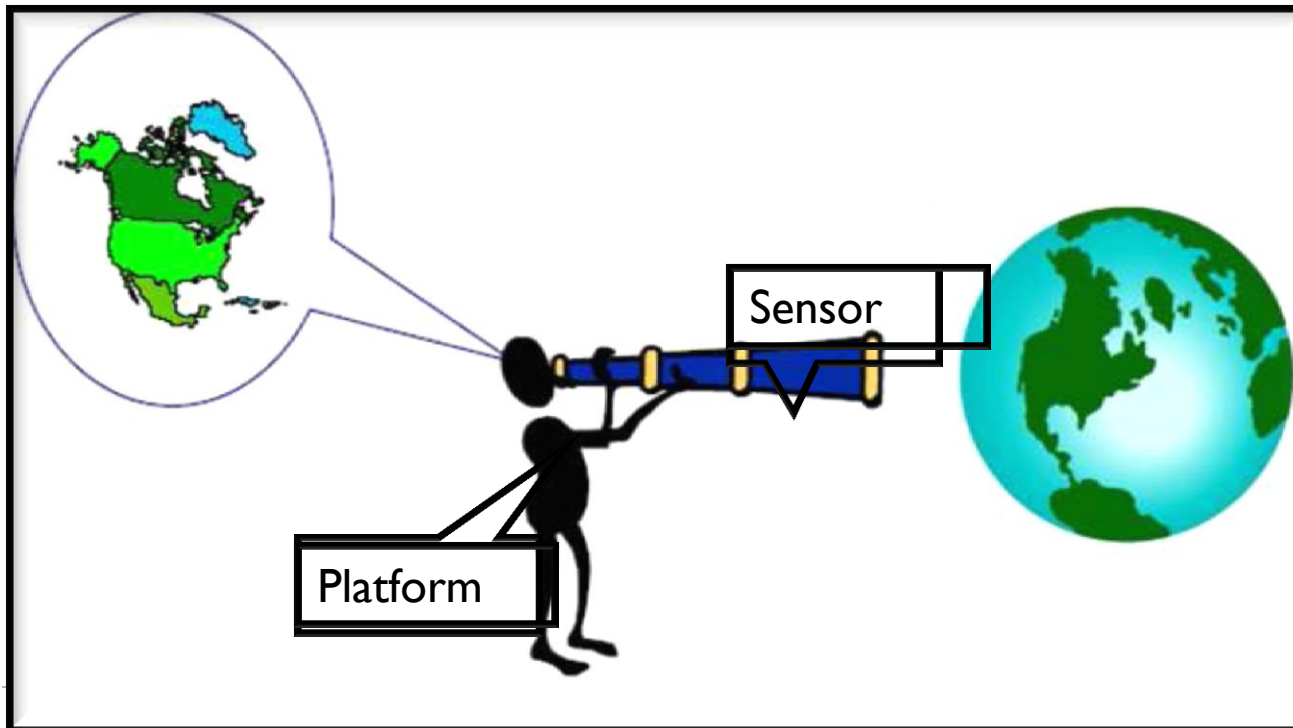

Platforms

- **Ground borne**



- **Airborne borne**

Aerial photography,
other sensors aboard
airplanes



Platforms

- **Space borne**

(move in orbit around earth)

- **Rockets**
- **Satellites**

- **Advantages**
- **Large area coverage**
- **Frequent and repetitive coverage of an area of interest**

IRS, Landsat, SPOT

▶ **meteorological satellites, AVHRR**



Depending upon their altitude & Orbit these platforms may be divided into:

Geostationary (70°N to 70°S)

- ❖ equatorial west to east satellite orbiting earth at an altitude of 35,000 km
- ❖ Continuous coverage over same area day/night

INSAT

❖ Polar orbiting or Sun-synchronous

- ❖ Satellite movement North to South
 - ❖ Relative speed between sun and satellite is zero
-



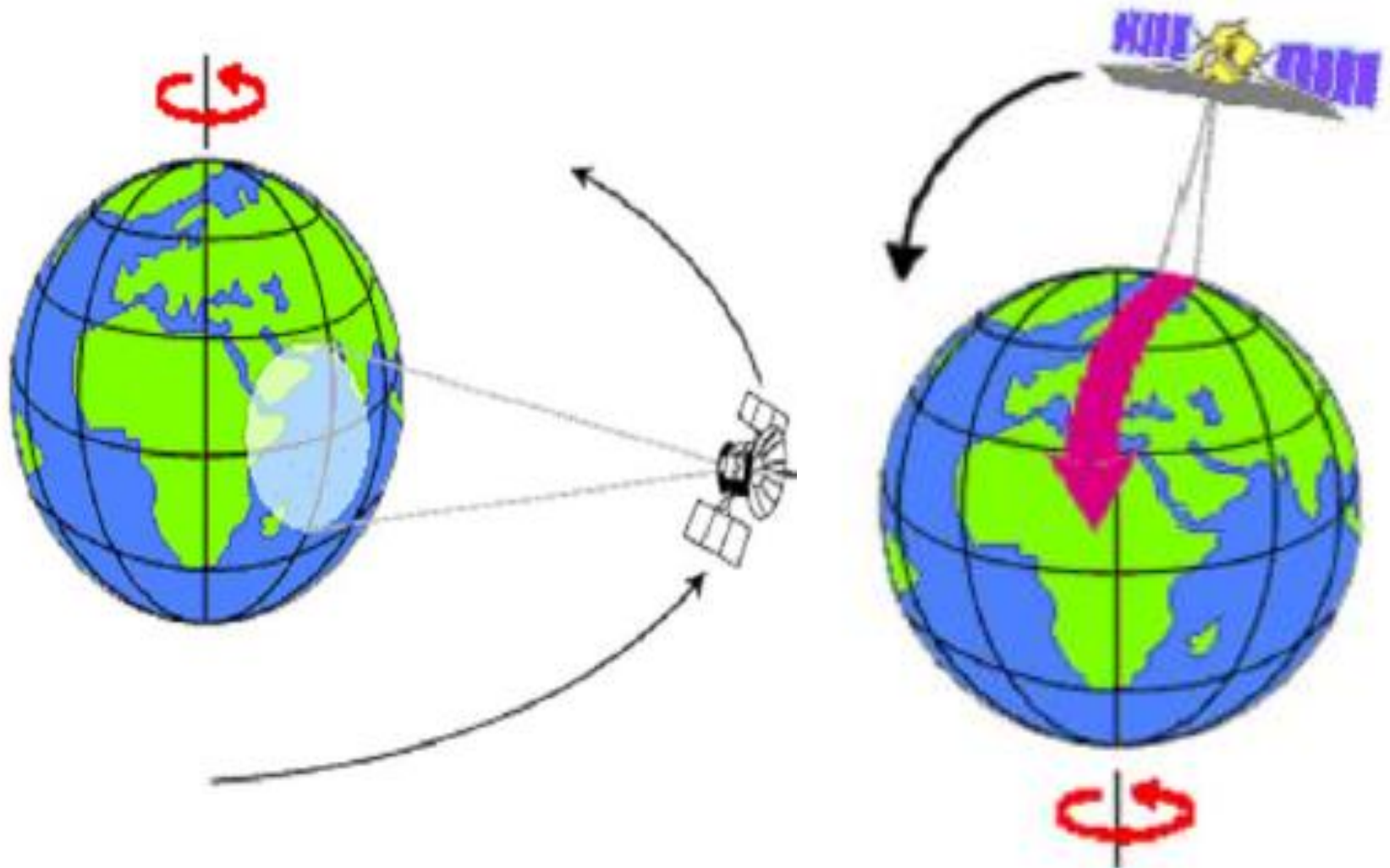

SATELLITE IN (a) GEOSTATIONARY ORBIT (b) NEAR POLAR ORBIT

Geosynchronous orbits allow the satellite to

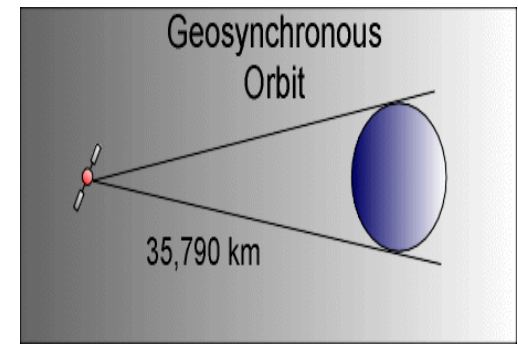

- observe big picture “almost a full hemisphere of the Earth”
- used to study large scale phenomenon such as hurricanes, or cyclones.
- also used for communication satellites.
- since these satellites are very far away, they have poor resolution.
- trouble monitoring activities near poles.

Satellites in polar or sun synchronous orbit

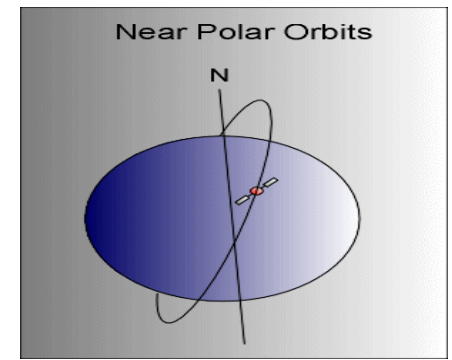

- Orbit at altitudes of 300 to 1400 km above earth.
- satellite is "watching" different sections of the earth in narrow bands.
- provide medium to high resolution images of the whole earth
- mostly used for environmental monitoring.
- Days or weeks later, the satellite orbits again above the same section.
- temporal resolution of these satellites is
 - ▶ limited

REMOTE SENSING SENSORS

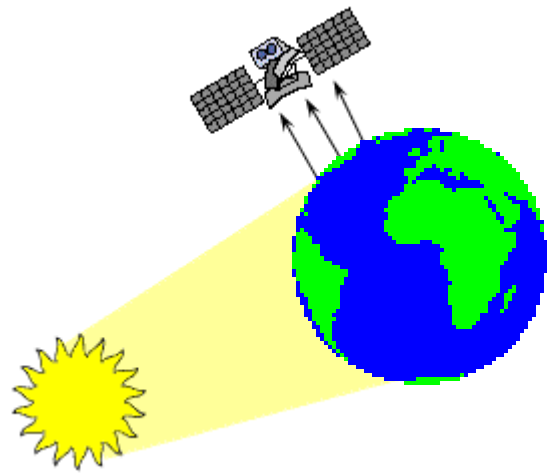

Passive sensors : measure energy that is naturally available (sun). The sun's energy is either reflected (visible), or absorbed and then re-emitted (thermal IR).

Active sensors : provide their own energy source for illumination. The sensor emits radiation which is directed towards the target to be investigated. The radiation reflected from that target is detected and measured by the sensor.

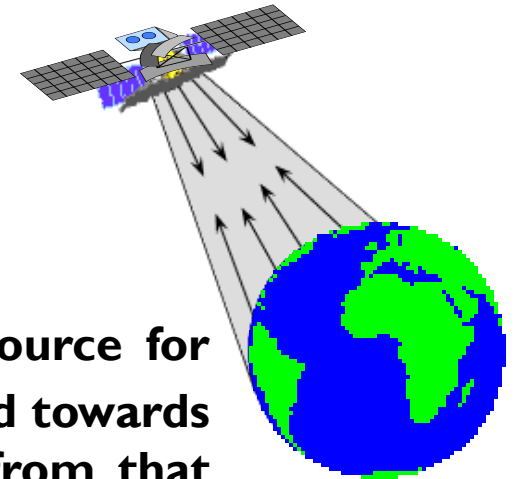

Resolution in Remote Sensing

- **Spatial:** ability of sensor to distinguish small objects; defines PIXEL size
 - **Spectral:** number of bands measured by sensor
 - **Radiometric:** sensitivity of sensor to detect differences in signal strength
 - **Temporal:** frequency of revisit time
-



Spatial Resolution, Pixel Size, and Scale

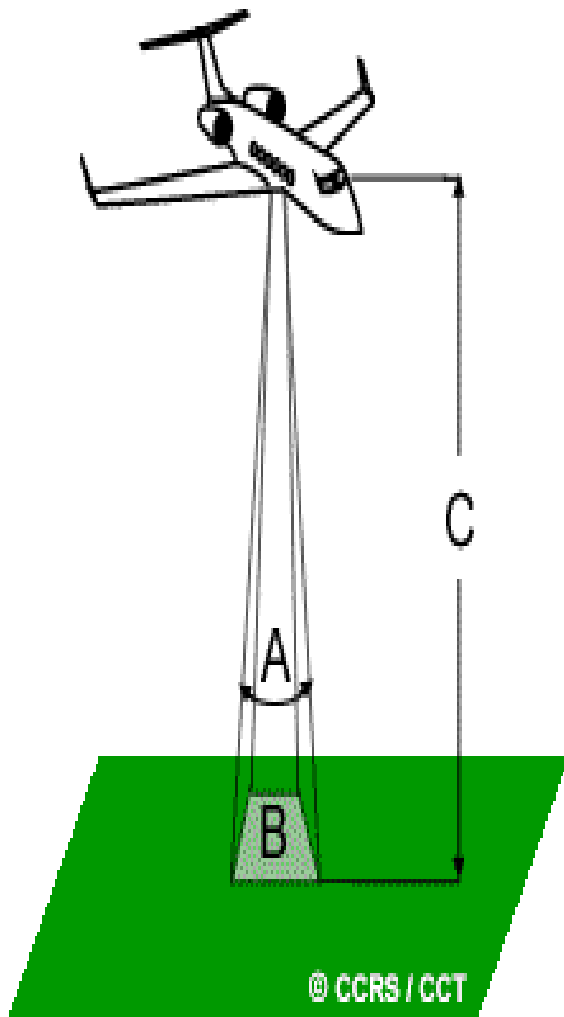

Spectral Resolution

Spectral resolution describes the ability of a sensor to define fine wavelength intervals. The finer the spectral resolution, the narrower the wavelength range for a particular channel or band.

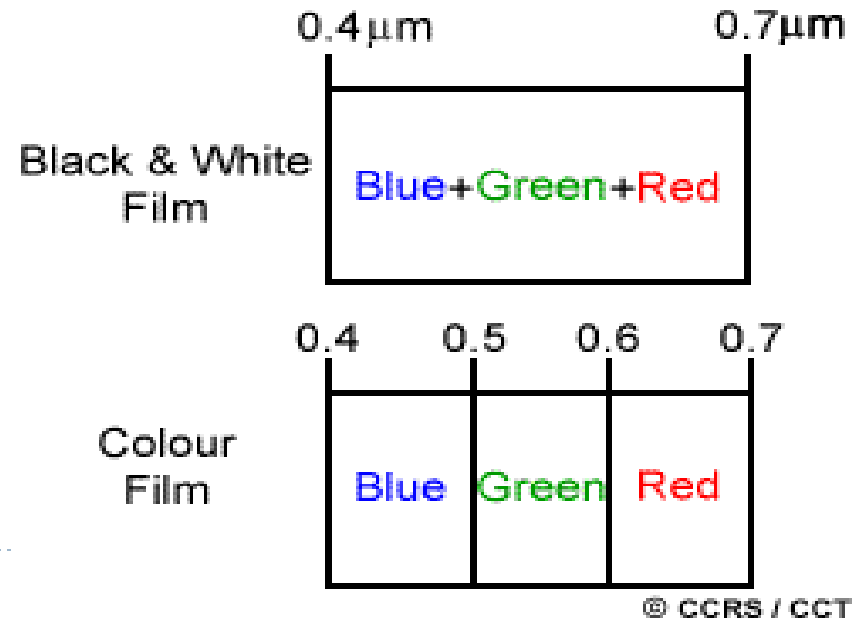
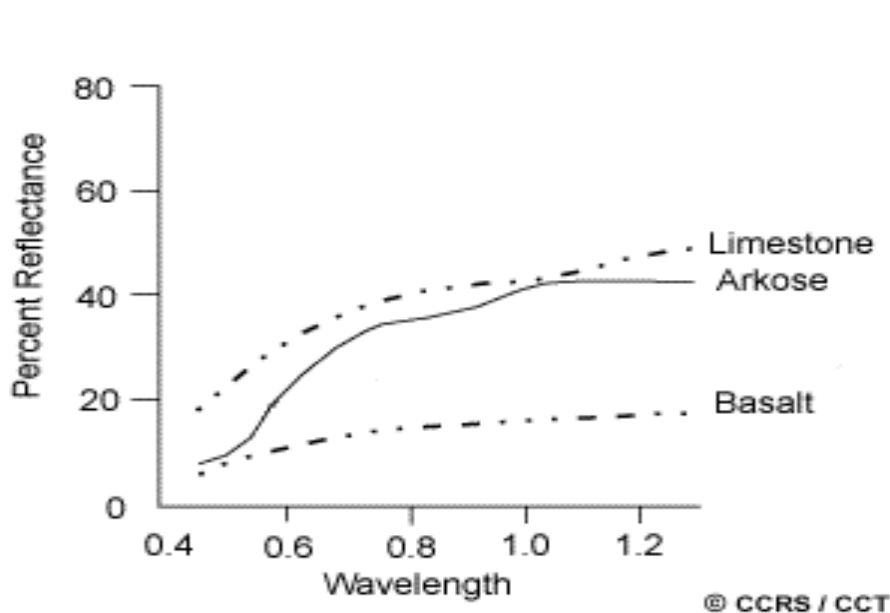

Radiometric Resolution

Every time an image is acquired on film or by a sensor, its sensitivity to the magnitude of the electromagnetic energy determines the **radiometric resolution**. The radiometric resolution of an imaging system describes its ability to discriminate very slight differences in energy. The finer the radiometric resolution of a sensor, the more sensitive it is to detecting small differences in reflected or emitted energy



Temporal Resolution

- Ability to collect imagery of the same area of the Earth's surface at different periods of time.
- Spectral characteristics of features may change over time and these changes can be detected by collecting and comparing **multi-temporal** imagery.

Time factor in imaging is important when:

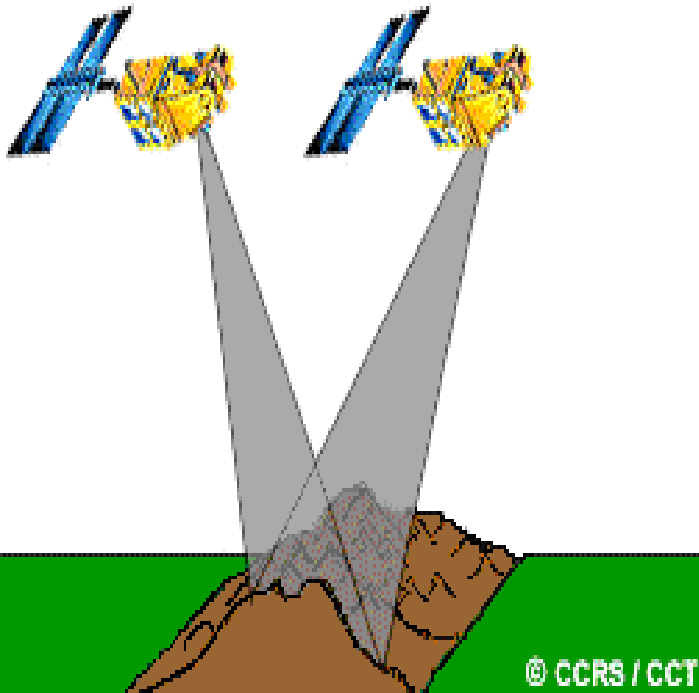

- persistent clouds offer limited clear views of the Earth's surface (often in the tropics)
- short-lived phenomena (floods, oil slicks, etc.) need to be imaged
- multi-temporal comparisons are required (e.g. the spread of a forest disease from one year to the next)
- the changing appearance of a feature over time can be used to distinguish it from near-similar features

Micro wave Remote Sensing

Microwave sensing encompasses both active and passive forms of remote sensing



**Longer wavelength
microwave radiation can
penetrate through cloud
cover, haze, dust, and all
but the heaviest rainfall**



Passive microwave sensing

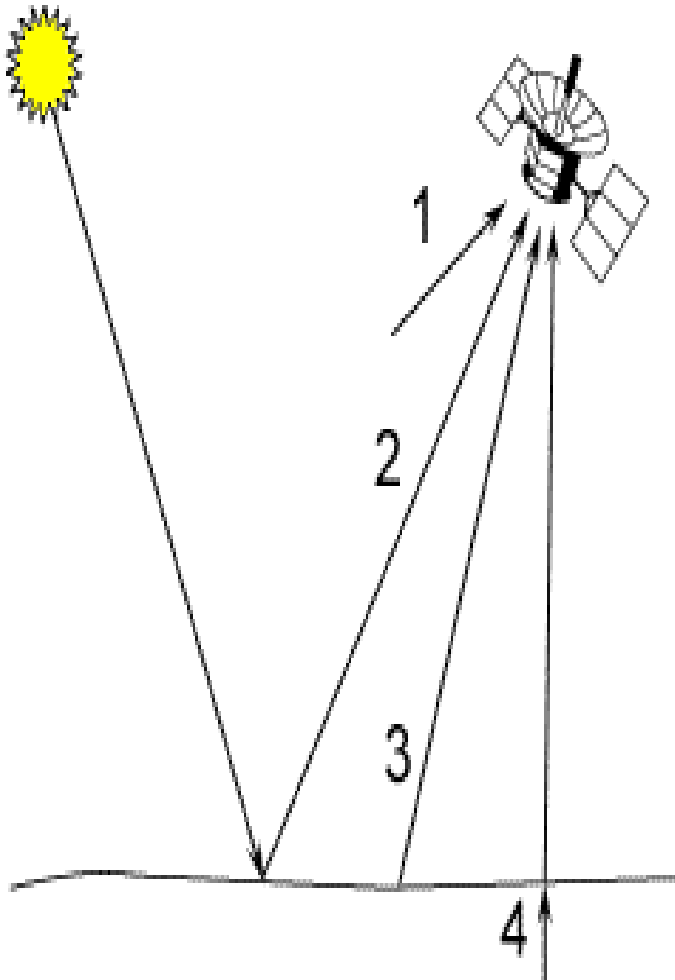

The microwave energy recorded by a passive sensor can be emitted by the atmosphere (1), reflected from the surface (2), emitted from the surface (3), or transmitted from the subsurface (4). Because the wavelengths are so long, the energy available is quite small compared to optical wavelengths

Active microwave sensors

Active microwave sensors provide their own source of microwave radiation to illuminate the target. Active microwave sensors are generally divided into two distinct categories: **imaging and non-imaging**. The most common form of imaging active microwave sensors is RADAR.

RADAR is an acronym for **RA**dio **D**etection **A**nd **R**anging, which essentially characterizes the function and operation of a radar sensor

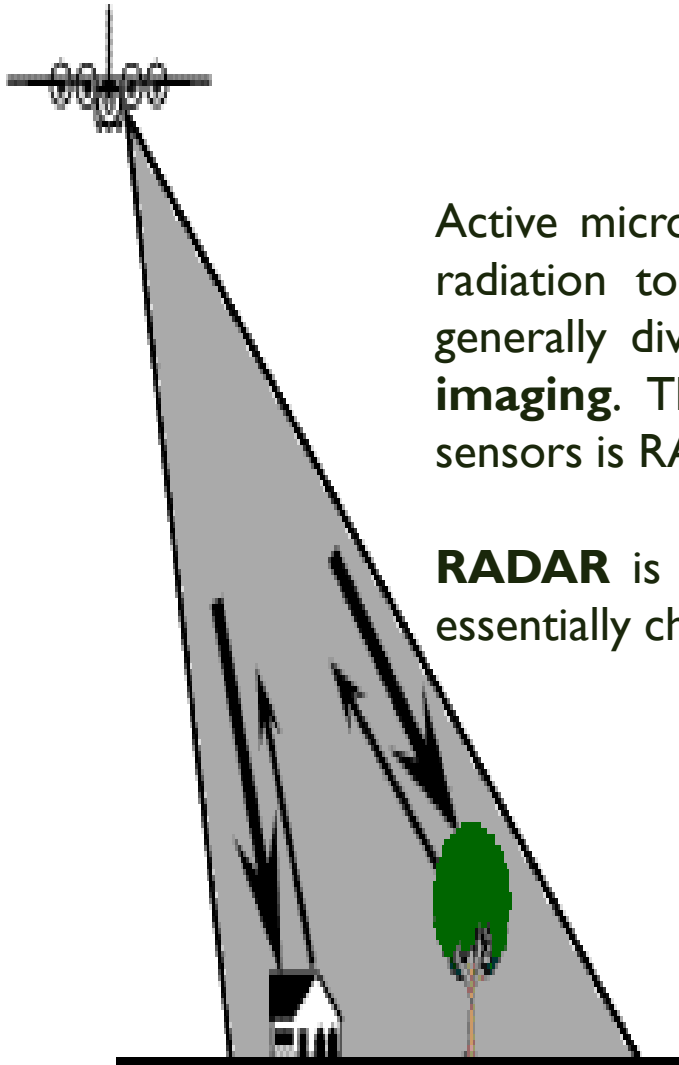

Satellites

- 1960's--first earth-orbiting weather satellites
- LANDSAT (1972): first non-military satellite to collect land resource data
- AVHRR (1979)
- SPOT (1986)
- IRS (1988)



Indian Earth Observation Satellites

2009
RISAT-2
X-SAR



2012
RISAT-1
C-SAR

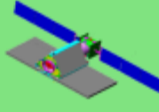

2007/ 2008/ 2010
CARTOSAT-2/2A/2B
PAN



2011
RESOURCESAT-2
LISS 3; LISS 4; AWiFS

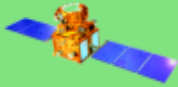

2003
RESOURCESAT-1
LISS 3; LISS 4; AWiFS

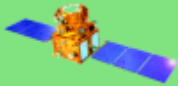

2008
IMS-1
MX HySI-T



Land & Water

2005
CARTOSAT-1
Stereo PAN, F/A



2001
TES
Step & Stare PAN



Cartographic

2009
OCEANSAT-2
OCM , SCAT
ROSA



Ocean & Atmosphere

2003
INSAT- 3A
VHRR, CCD



2011
Megha Tropiques
MADRAS, SAPHIR
SCaRaB



2002
KALPANA-1
VHRR

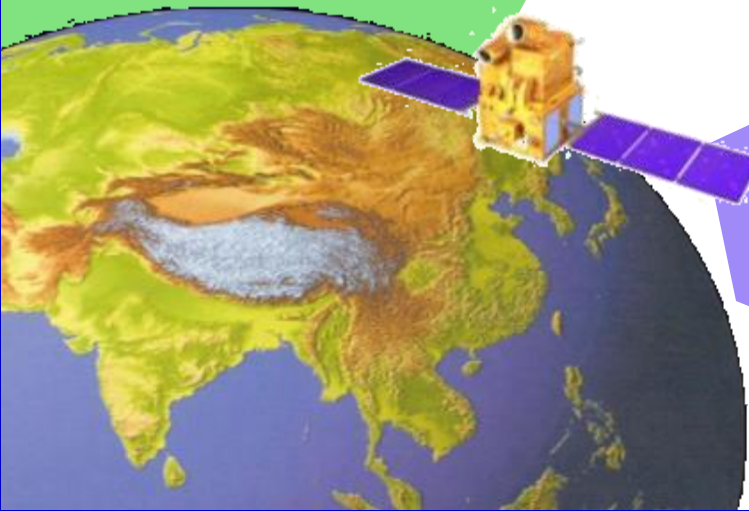

Satellite Data Availability

HIGH RESOLUTION	MEDIUM RESOLUTION	LOW RESOLUTION
IRS missions		
Cartosat-2 (1m B/W)	Res' sat-1,2,1C,1D (L3 23.5m)	IRS-1C,1D (WiFS 188m)
Cartosat-1 (2.5m B/W)	Resourcesat-1,2 (AWiFS 58m)	Oceansat-1 &2 (OCM 360m)
IRS 1C,1D PAN (5.8m B/W)	IRS-1A,1B (LI 72.5m)	RISAT-1 (CRS 48m)
Resourcesat-1, 2 (L4MX 5.8m)	IRS-1A,1B,1C,1D (L2 36.25m)	
RISAT-1 (FRS-1, 3m)	RISAT-1 (MRS 24m)	
Foreign Missions		
	Landsat (TM 30m, MSS 80m)	MODIS (AQUA/TERRA 1km)
	SPOT (PLA 10m, MLA 20m)	AVHRR (NOAA 1km)



Earth Observation Satellites – Land missions

YEAR	L-1&2 MSS	L-2 MSS	L-3 MSS	L-4 MSS	L-5 MSS	L-5 TM	SPOT - 1	IRS-1A	IRS-1B	ERS- 1/2	IRS-P2	IRS-1C	IRS-P3	IRS-1D	IRS-P6	IRS-P5	IRS-C2	RESO URCE SAT-2	RISAT- 1	
1979	1979	1979																		
1980	1980	1980	1980																	
1981		1981	1981	1981																
1982		1982	1982	1982																
1983			1983	1983																
1984				1984																
1985				1985	1985	1985														
1986				1986	1986	1986														
1987				1987	1987	1987														
1988				1988	1988	1988	1988	1988	1988											
1989				1989	1989	1989	1989	1989	1989											
1990				1990	1990	1990	1990	1990	1990											
1991					1991	1991	1991	1991	1991	1991	1991	1991	1991	1991	1991	1991	1991	1991	1991	1991
1992						1992	1992	1992	1992	1992	1992	1992	1992	1992	1992	1992	1992	1992	1992	1992
1993							1993	1993	1993	1993	1993	1993	1993	1993	1993	1993	1993	1993	1993	1993
1994							1994	1994	1994	1994	1994	1994	1994	1994	1994	1994	1994	1994	1994	1994
1995							1995	1995	1995	1995	1995	1995	1995	1995	1995	1995	1995	1995	1995	1995
1996							1996	1996	1996	1996	1996	1996	1996	1996	1996	1996	1996	1996	1996	1996
1997							1997	1997	1997	1997	1997	1997	1997	1997	1997	1997	1997	1997	1997	1997
1998							1998	1998	1998	1998	1998	1998	1998	1998	1998	1998	1998	1998	1998	1998
1999							1999	1999	1999	1999	1999	1999	1999	1999	1999	1999	1999	1999	1999	1999
2000							2000	2000	2000	2000	2000	2000	2000	2000	2000	2000	2000	2000	2000	2000
2001							2001	2001	2001	2001	2001	2001	2001	2001	2001	2001	2001	2001	2001	2001
2002								2002	2002	2002	2002	2002	2002	2002	2002	2002	2002	2002	2002	2002
2003								2003	2003	2003	2003	2003	2003	2003	2003	2003	2003	2003	2003	2003
2004								2004	2004	2004	2004	2004	2004	2004	2004	2004	2004	2004	2004	2004
2005									2005	2005	2005	2005	2005	2005	2005	2005	2005	2005	2005	2005
2006										2006	2006	2006	2006	2006	2006	2006	2006	2006	2006	2006
2007											2007	2007	2007	2007	2007	2007	2007	2007	2007	2007
2008												2008	2008	2008	2008	2008	2008	2008	2008	2008
2009													2009	2009	2009	2009	2009	2009	2009	2009
2010														2010	2010	2010	2010	2010	2010	2010
2011															2011	2011	2011	2011	2011	2011
2012																2012	2012	2012	2012	2012

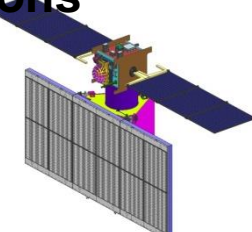

RISAT 1
Microwave C-band



Resourcesat 2
LISS 3 (23m)
LISS 4 (5.8m)
AWiFS (55m)



CARTOSAT-2
PAN 1m



Cartosat 1
PAN-2.5M, F/A



Resourcesat 1
LISS 3 (23m)
LISS 4 (5.8m)
AWiFS (55m)

Landsat
MSS (82m)
TM (30 m)

Spot
Multi Spectral (20m)
Pan (10 m)

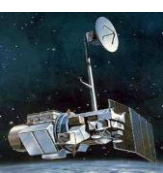

IRS-1A & 1B
LISS-1&2 (72/36m)

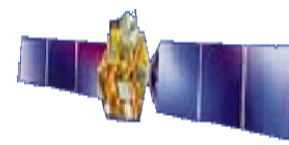

IRS-1C/1D
LISS-3 (23/70m)
PAN (5.8m);
WiFS (188m)



IRS-P3
WiFS;
MOS X-Ray

SATELLITE DATA PRODUCTS

Data collected by different types of sensor

~~User~~ → community

Hard Copy- whose contents cannot be changed

paper prints: B&W, Color

Negative films: B&W, Color

Soft Copy- available in digital data (Raster form)
recorded on magnetic media (CDs, Pen drives)

Digital data can be seen in 3 ways

- Image- in form of picture
- Graphical- in form of histogram
- Tabular- in form of table having DN value



So, what are RS data?

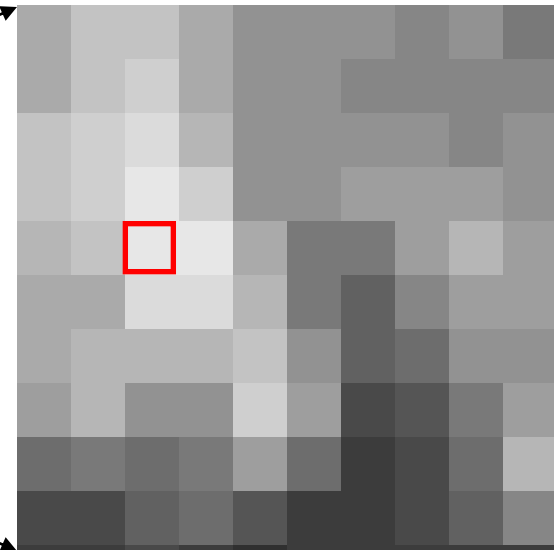
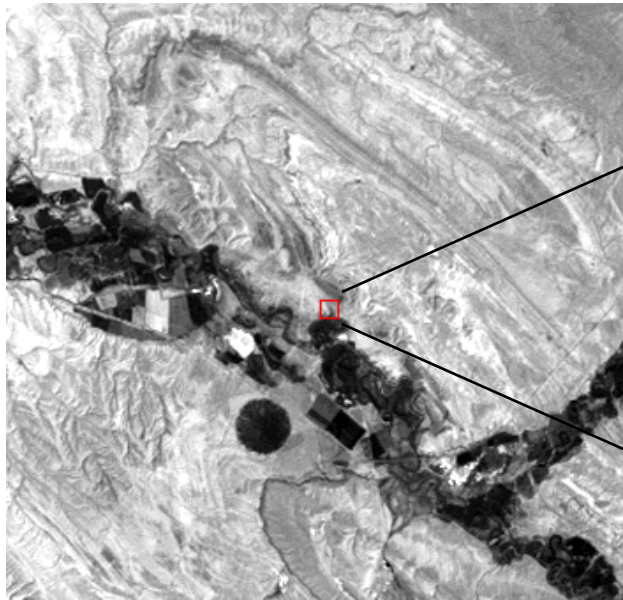

- RS imagery is raster data.
- Each pixel has a geographic coordinate and reflectance/intensity value, or digital number (DN).

18	20	20	18	16	16	16	15	16	14
18	20	21	18	16	16	15	15	15	15
20	21	22	19	16	16	16	16	15	16
20	21	23	21	16	16	17	17	17	16
19	20	23	23	18	14	14	17	19	17
18	18	22	22	19	14	12	15	17	17
18	19	19	19	20	16	12	13	16	16
17	19	16	16	21	17	10	11	14	17
13	14	13	14	17	13	9	10	13	19
10	10	12	13	11	9	9	10	12	15

Soft copy (Reverse Scanner) → Hardcopy

Hard copy can be converted to soft copy but cannot be used for digital interpretation but only for manual interpretation

Methods for Interpretation

- **Manual**- Hard copy required, devices such as enlarger, magnifying lens, tracing table
- **Digital**- Soft copy is used and software and Hardware required



Display of RS data

- **Grayscale image:** One band, with each pixel represented by a grayscale value
- **Multispectral Display**
 - Combining 3 bands, assigned to the three color channels (red, green, blue).
 - **True color composite:** Colors in the image roughly correspond with the colors in the real world
 - **False color composite:** Showing colors that don't really exist in that location.
 - **Key:** Showing best contrast between feature classes that may be indistinguishable to the human eye.



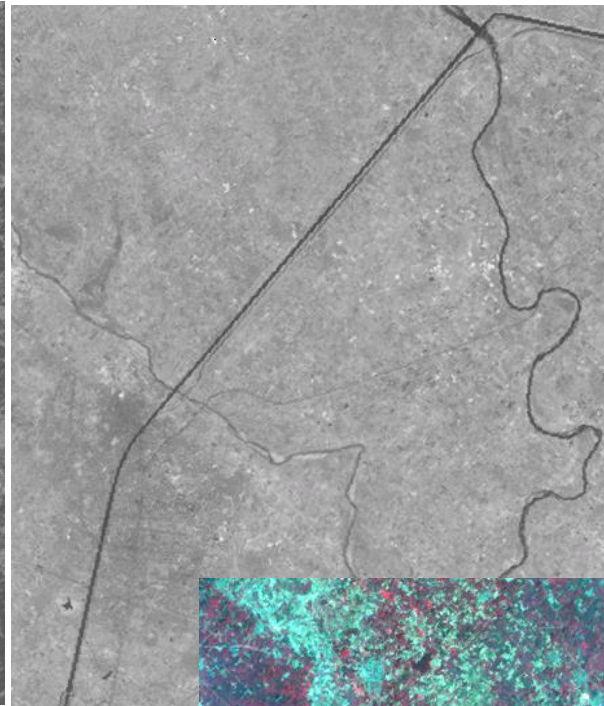
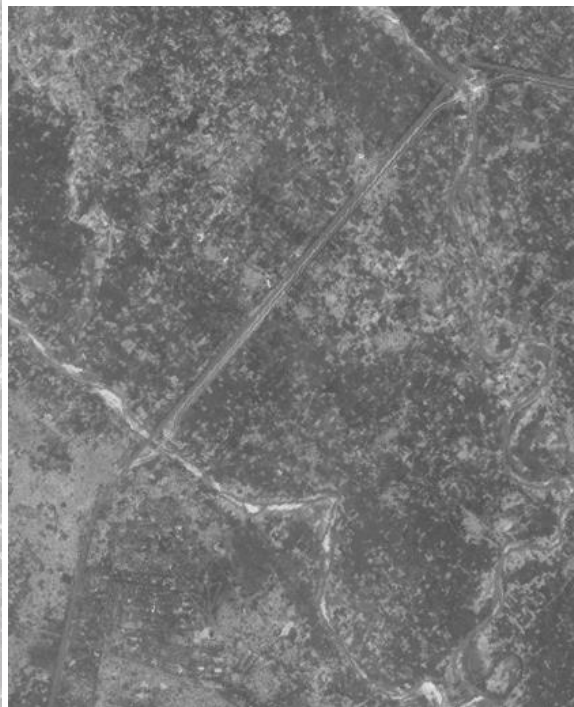

BAND 1

BAND 2

BAND 3

FASLE COLOUR COMPOSITE (FCC)

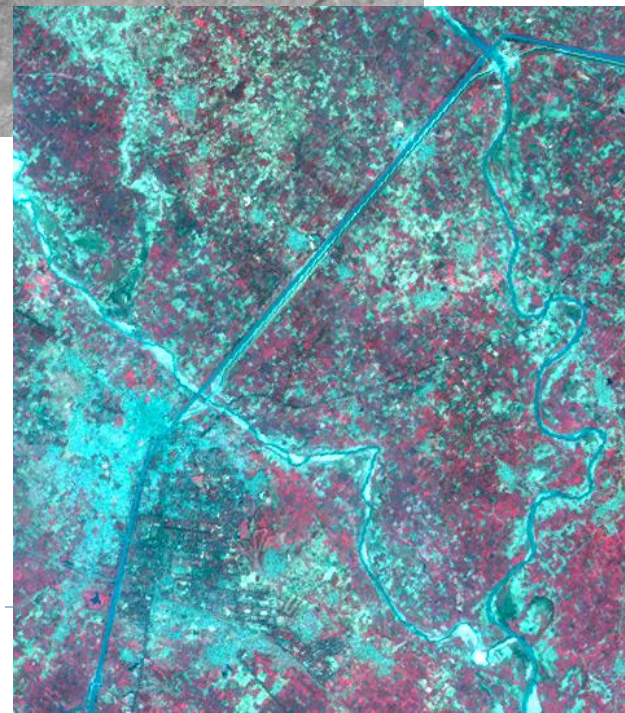

Examples of various resolutions

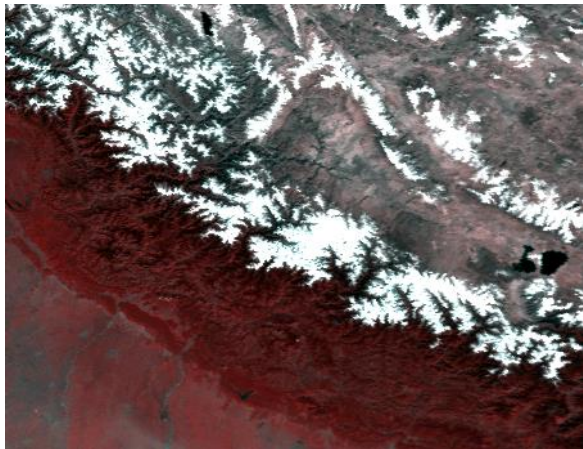

NOAA (1km.)

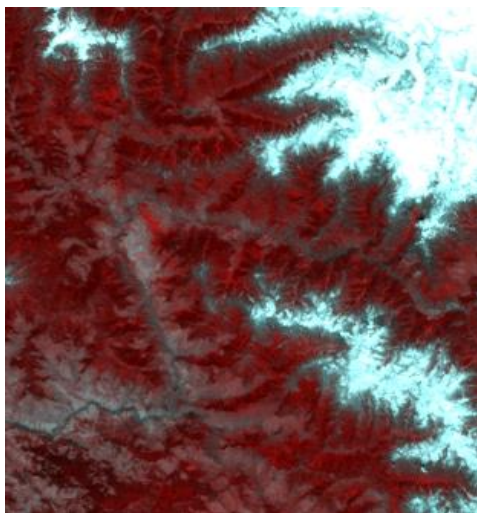

(IRS WiFS 188m)

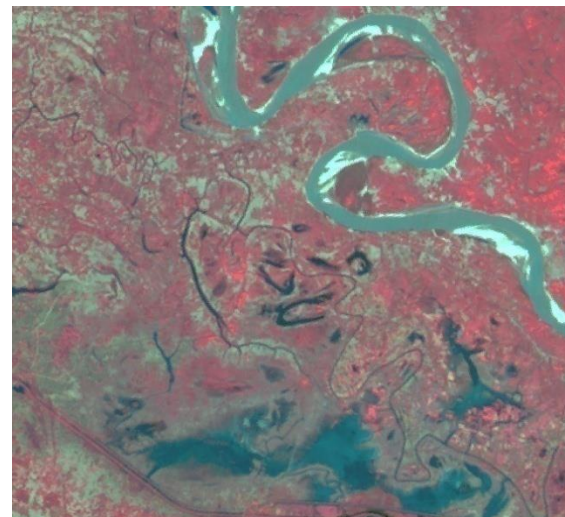

(IRS LISSII 36 m)

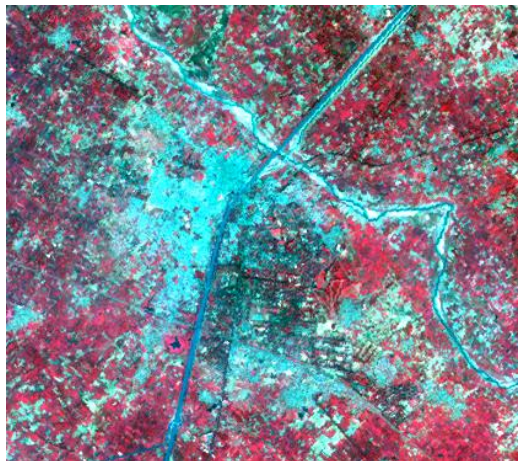

(IRS LISIII 23.5 m)



(IRS PAN 6 m)



CARTOSAT (2.5 m)

IKONOS IMAGE OF IIRS ON 19-4-2001



IKONOS IMAGE OF DEHRADUN ON 19-4-2001



What is a GIS?

A Geographical Information System (GIS) is a system for creating, storing, analyzing and managing spatial data and associated attributes. In a more generic sense, GIS is a tool that allows users to create interactive queries (user created searches) analyze the spatial information, and edit data.

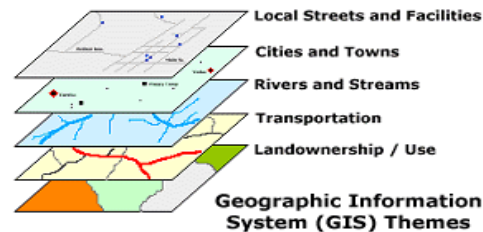

Encoded spatial data are systematically stored in the form of layers called GIS layers

In combination with up to-date data from remote sensing a GIS can assist in automation of several operations like interpretation, change detection, map revisions etc.

GIS components

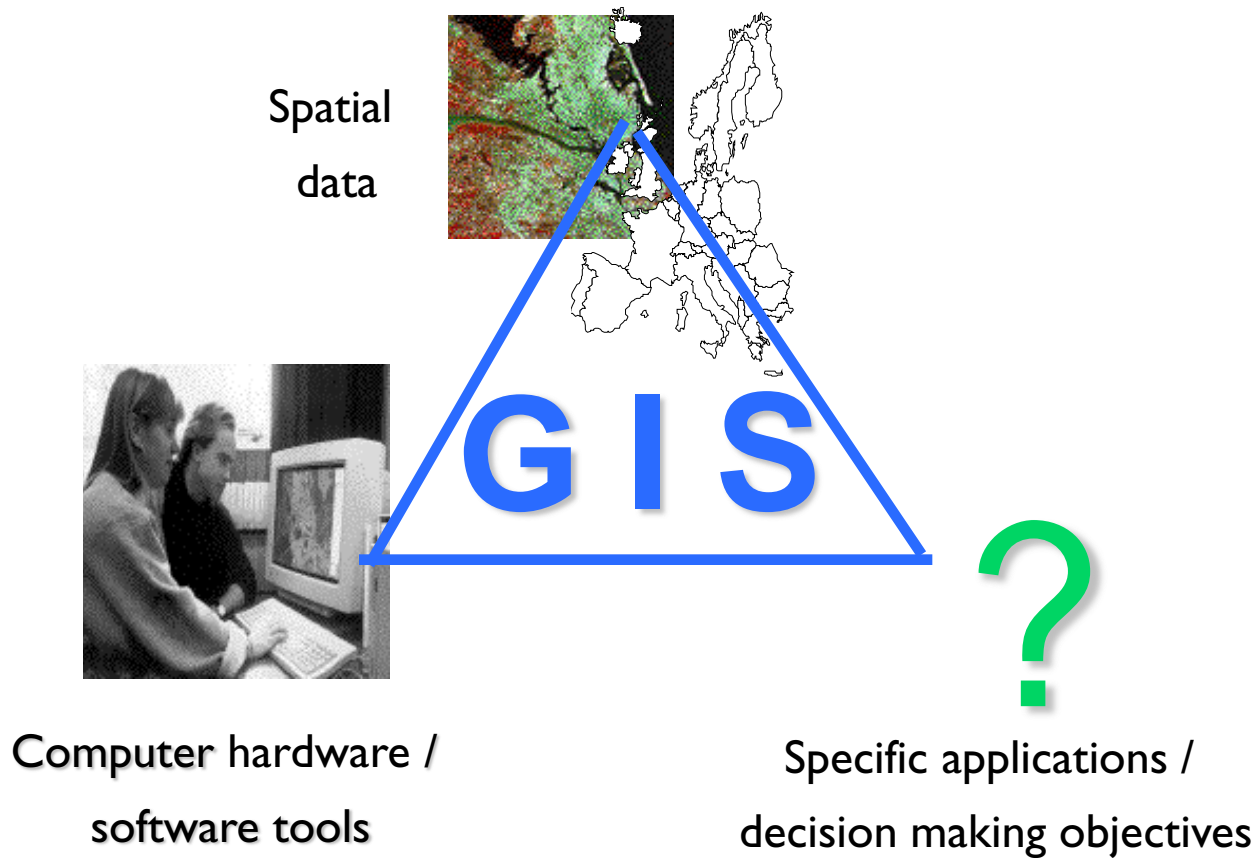

GIS Objectives

- ▶ Maximize the efficiency of planning and decision making
- ▶ Provide efficient means for data distribution & handling
- ▶ Elimination of redundant database-minimize duplication
- ▶ Capacity to integrate information from many sources
- ▶ Complex analysis/query involving geographical reference data to generate new information



Handling of Spatial and Non-spatial data in GIS

Two types of data storages in a GIS

- ▶ **Raster**- space is assumed to be divided into grids of cells
- ▶ **Vector**- particular point stored as point, line and polygon



Data Structures

Raster data structure

In a raster data structure, map is divided into an array of square pixels – each of which has a value. For example, 1 may be road, 2 pasture, 3 water, etc.

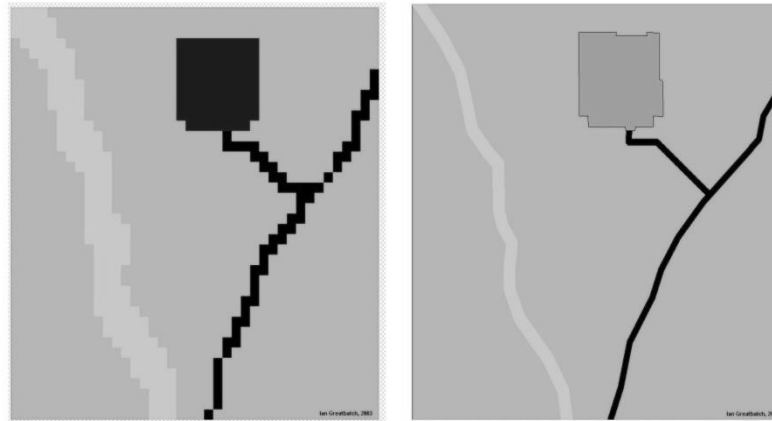

Raster Data Structure Vector Data Structure

Vector data structure

The other (and most common) form of GIS data structure is the vector data structure or object approach. Geographical objects are constructed of point, lines and polygons. In the view above the house is a polygon, constructed of lines that change direction at points.



Spatial data storage

▶ Vector model

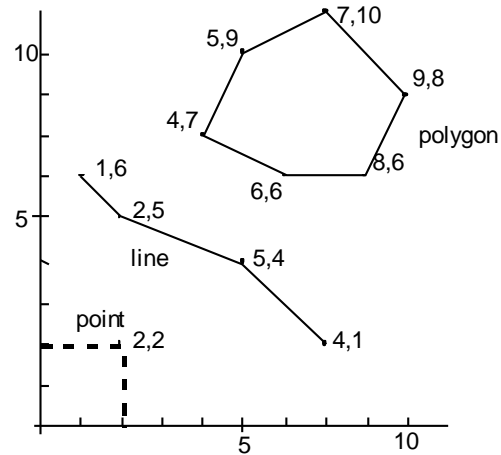

as geometric objects:
points, lines, polygons

▶ Raster model

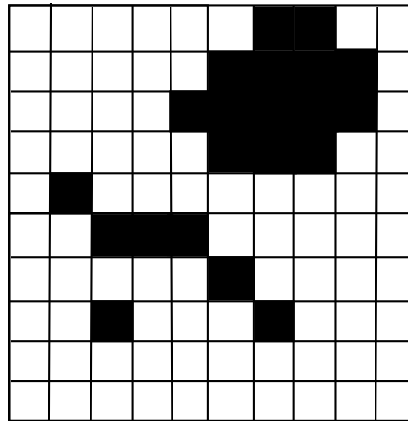

as image files
composed of grid-cells
(pixels)

Raster-Vector Data Model

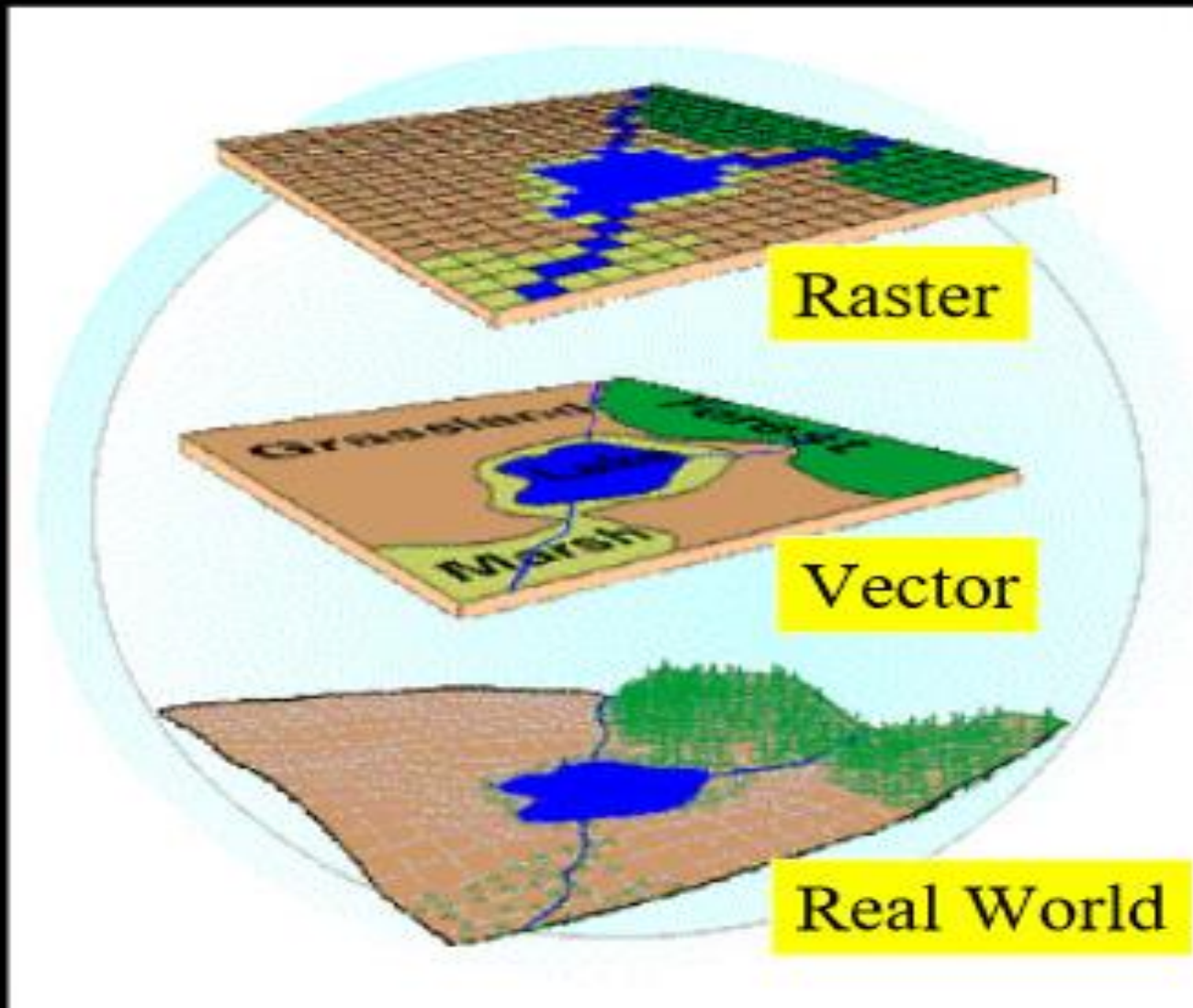

Sources of data inputs to GIS

- ▶ Remote sensing
- ▶ Field mapping
- ▶ GPS
- ▶ Direct field observations
- ▶ Records



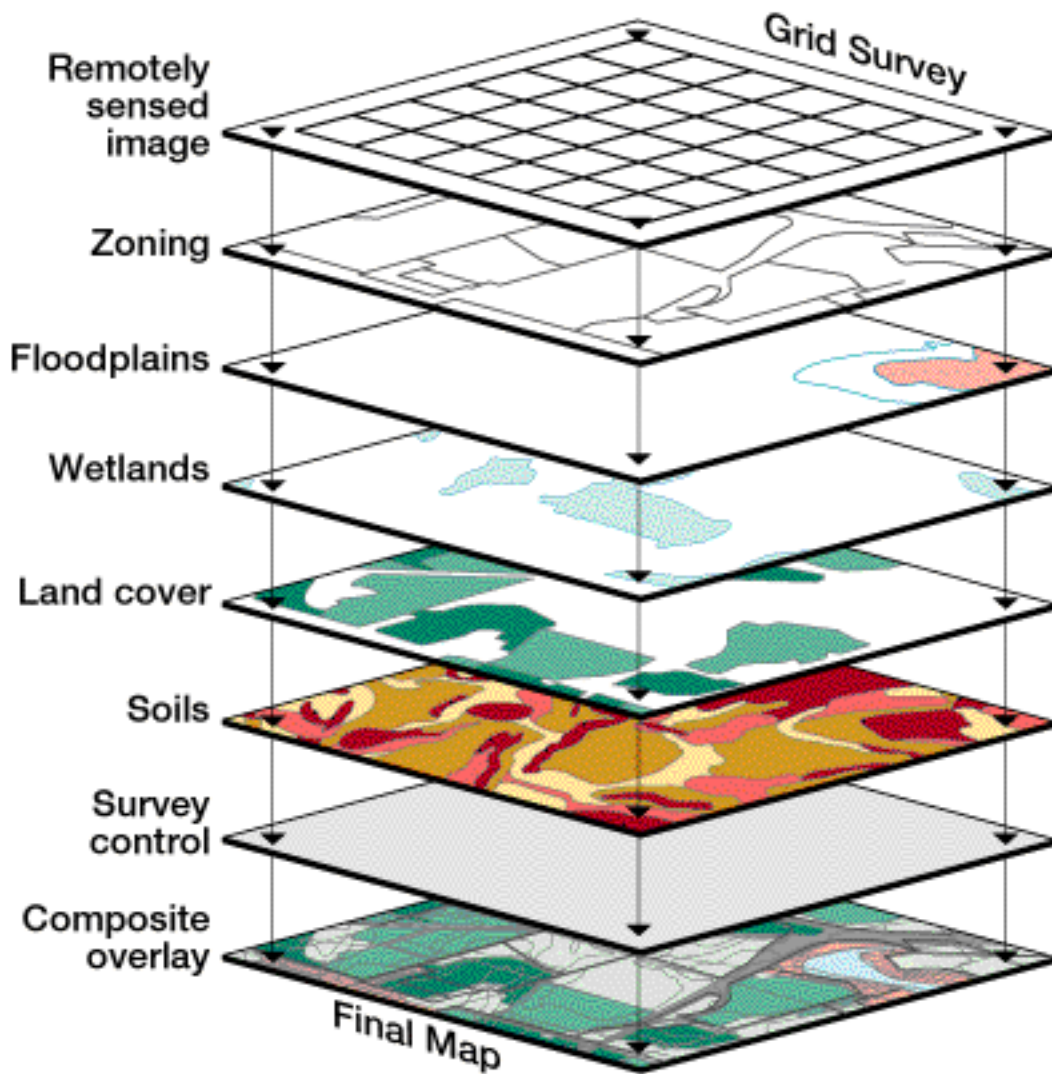

Geographical Information System (GIS)

- ▶ Capturing data
- ▶ Storing data
- ▶ Querying data
- ▶ Analyzing data
- ▶ Visualization/Displaying data in various formats



SOFTWARE

Three groups of GIS:

Web-based GIS: ONS and London Profiler

Geobrowser: Google Earth

Desktop GIS: ArcGIS

**PROPRIETARY
SOFTWARE**

SOFTWARE	FIRM
ArcGIS Desktop	ESRI
ERDAS Imagine	Leica (Hexagon Geospatial)
MapInfo	Pitney Bowes
IDRISI	Clark University
SmallWorld	General Electric
Autodesk	
TNTMips	
Surfer	
RockWor	

**OPEN SOURCE
SOFTWARE**

SOFTWARE
GRASS
Quantum GIS
ILWIS
MapWindow
uDig
JUMP
Kalypo
TerraView



Application of RS & GIS

URBAN FLOOD INUNDATION MAPPING

- To define spatial extent of flood inundation.
- To identify the worst flood affected areas.
- To evaluate impact of flooding on environmental concerns, such as, coastlines, forests, open space etc.
- To plan relief operation.
- To assess damage.

RIVER MORPHOLOGICAL STUDIES

- To identify the changes in river course over a time period.
- To identify the erosion prone areas along the river course.
- To study the efficacy of flood management structures

URBAN FLOOD ZONING

Space inputs in Storm water management

- ▶ Digital Elevation models (DEM)
Cartosat, Aster, SRTM: Flow direction, Flow accumulation, stream/ drainage network basin delineation and road network
- ▶ Land use/ land cover (LULC) (Pre and Post disaster)
- ▶ Snow cover series (AWiFS, MODIS)
- ▶ SAR image during cloud cover
- ▶ River cross section (Pre and Post event)
- ▶ Precipitation (INSAT/Kalpana Rainfall, TRMM, Aphrodite)



Satellite/sensors for flood Monitoring

Sl No:	Satellite	Sensor/ Mode	Spatial Resolution (m)	Spectral Resolution (μm)	Swath (km)	Used For
1.	IRS-P6	AWiFS	56	B2 : 0.52-0.59 B3 : 0.62-0.68 B4 : 0.77-0.86 B5 : 1.55-1.70	740	Regional level flood mapping
2.	IRS-P6	LISS-III	23.5	B2 : 0.52-0.59 B3 : 0.62-0.68 B4 : 0.77-0.86 B5 : 1.55-1.70	141	District-level flood mapping
3.	IRS-P6	LISS-IV	5.8 at nadir	B2 : 0.52-0.59 B3 : 0.62-0.68 B4:0.77-0.86	23.9	Detailed Mapping
4.	IRS-1D	WiFS	188	B3: 0.62-0.68 B4 : 0.77-0.86	810	Regional level flood mapping
5.	IRS-1D	LISS-III	23.5	B2: 0.52-0.59 B3 : 0.62-0.68 B4: 0.77-0.86 B5:1.55-1.70	141	Detailed Mapping
6.	Aqua / Terra	MODIS	250	36 in visible NIR & thermal	2330	Regional level Mapping
7.	IRS-P4	OCM	360	Eight narrow bands in visible & NIR	1420	Regional level Mapping
8.	Cartosat-1	PAN	2.5	0.5-0.85	30	Detailed Mapping
9.	Cartosat-2	PAN	1	0.45-0.85	9.6	Detailed Mapping
10.	Radarsat-1	SAR/ ScanSAR Wide	100	C-band (5.3 cm; HH Polarization)	500	Regional level mapping
11.	Radarsat-1	SAR /ScanSAR Narrow	50	C-band (5.3 cm)	300	District-level mapping
12.	Radarsat-1	Standard	25	C-band	100	District-level mapping
13.	Radarsat-1	Fine beam	8	C-band (5.3 cm)	50	Detailed mapping
14	Radarsat-2	SAR	3m ultra-fine mode and 10m multi-lik fine mode	C –band	20 in ultra fine mode	Detailed mapping
14	ERS	SAR	25	C-band ; VV Polarization	100	District-level mapping

Requirement

Metrological

- ▶ Rainfall, ET

Hydrological

- ▶ River basin Chts
- ▶ LU/LC, Soils, Slope
- ▶ Drainage, etc

River characteristics

- ▶ X-section
- ▶ **Impact Assessment**
- **Flood extent**
- **Flood damages**

Space Technology can provide

INSAT

- Rainfall,

IRS

- LU/LC, Soils, Slope

DEM

- Flow direction, Flow accumulation, Watershed, Storm water Drainage, etc.
- **Flood Mapping, Updation**
- **Submerged**
 - **Crops, Roads, Rail etc.**
- **Duration of flooding**



Mitigation Phase

Requirement

Structural Measures

- ▶ Embankments, Dams etc.

Non-structural measures

- ▶ Flood plain Zoning

Restoration

RS & GIS provides

- River configuration
- Bank erosion
- Status of Embankments
- Flood Hazard Mapping
- Drainage congestion



Response and recovery phase

Requirement

- ▶ **Evacuation**
- ▶ **Impact Assessment**
 - **Flood extent**
 - **Flood damages**
- ▶ **Restoration**

RS & GIS provides

- **Optimum routing**
- **Flood Mapping, Updation**
- **Submerged**
 - **Crops, Roads, Rail etc.**
- **Duration of flooding**



Integration of RS, GIS, DEM and Hydrological Models

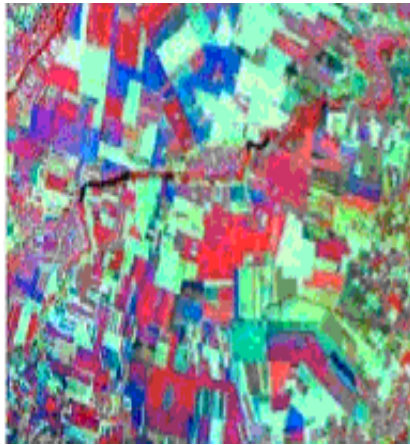

RS

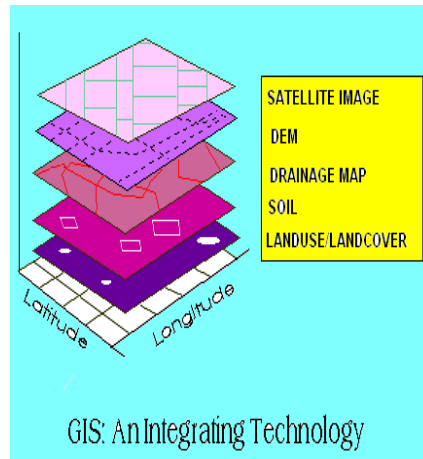

GIS

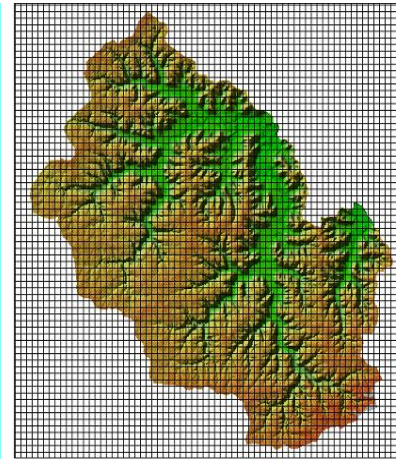

DEM

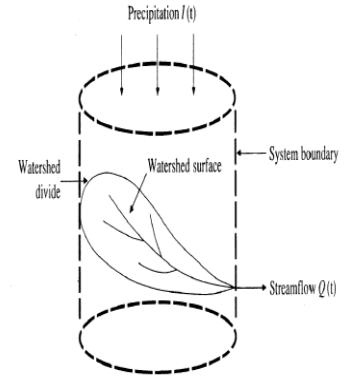
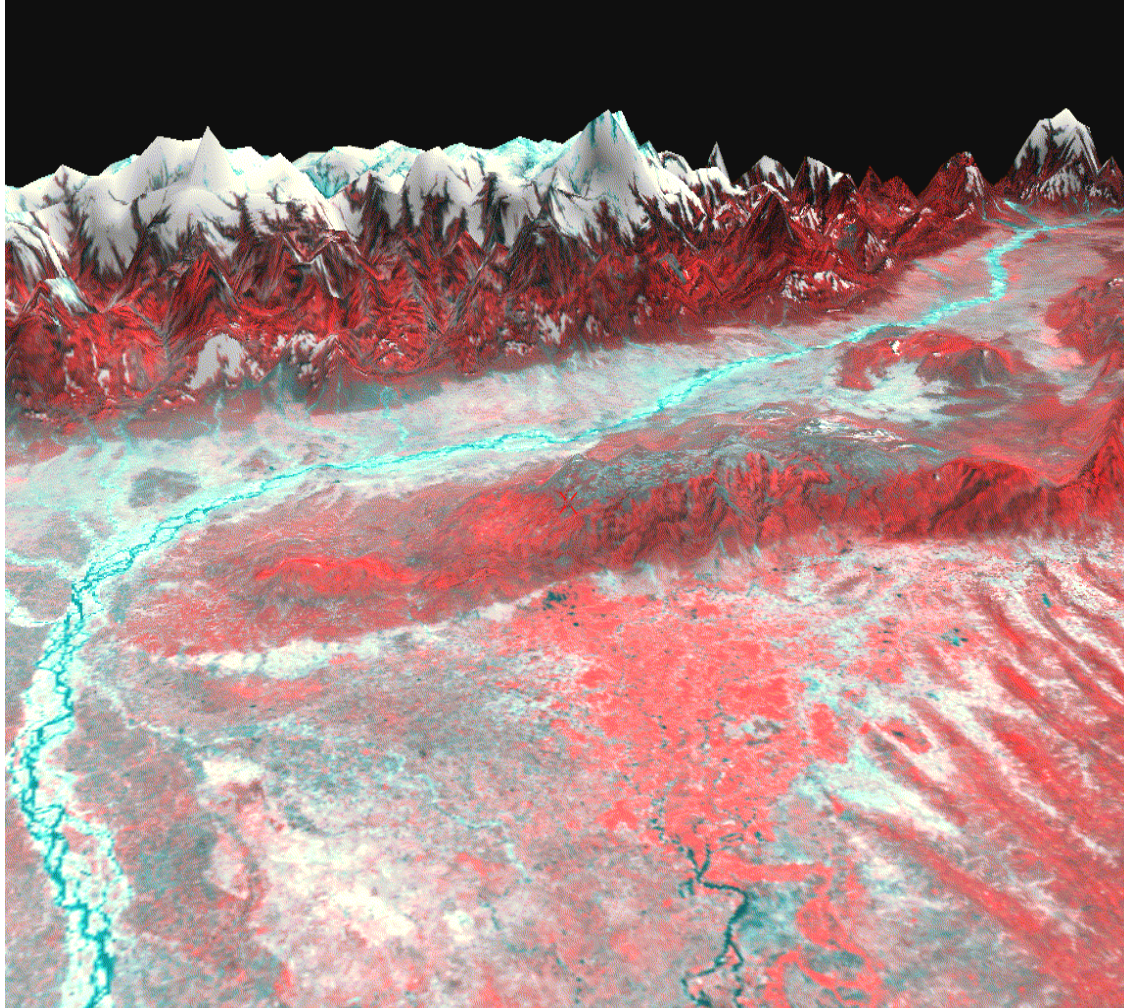

Fig. 1.1 The watershed as a hydrologic system (from Chow et al. 1988)

MODEL

DEM



Inputs from DEM

- Flow direction
- Flow accumulation
- Stream network
- Watershed



Land use/ Land cover

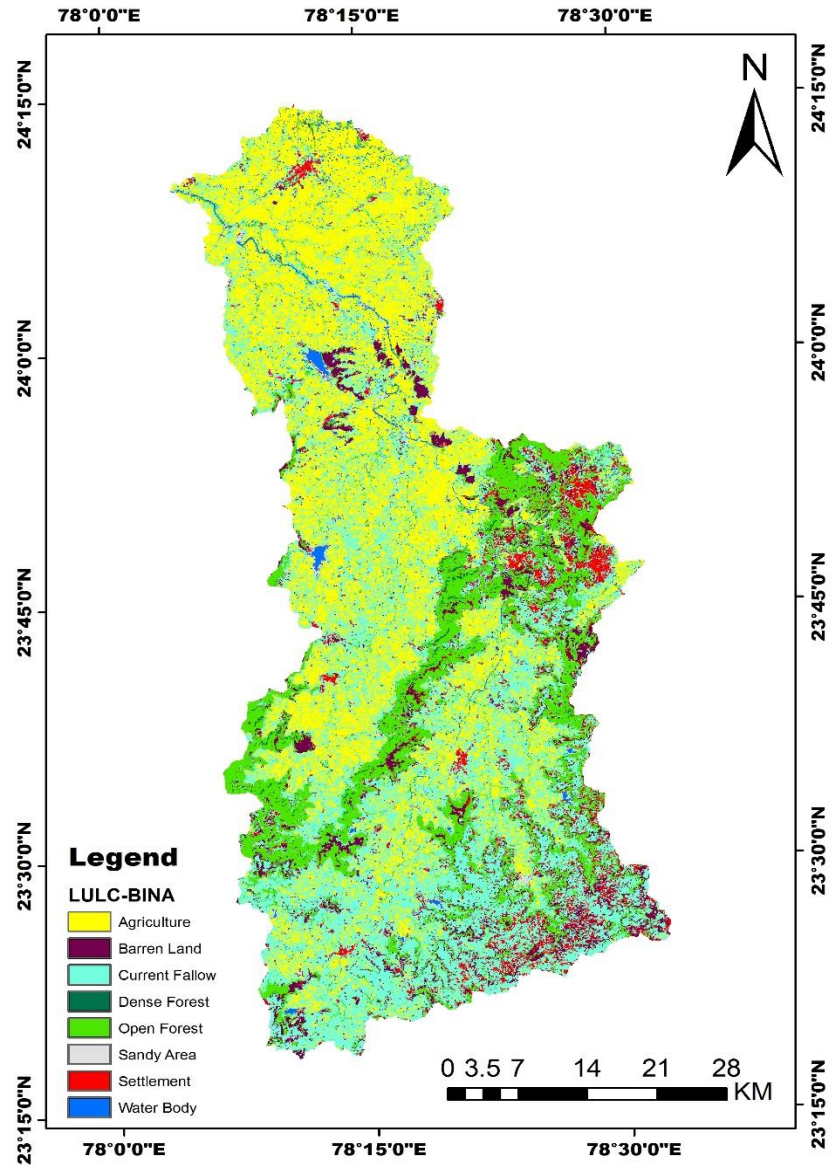

Landsat 8: 145/43 and 145/44



(March 25, 2015)

Soil map

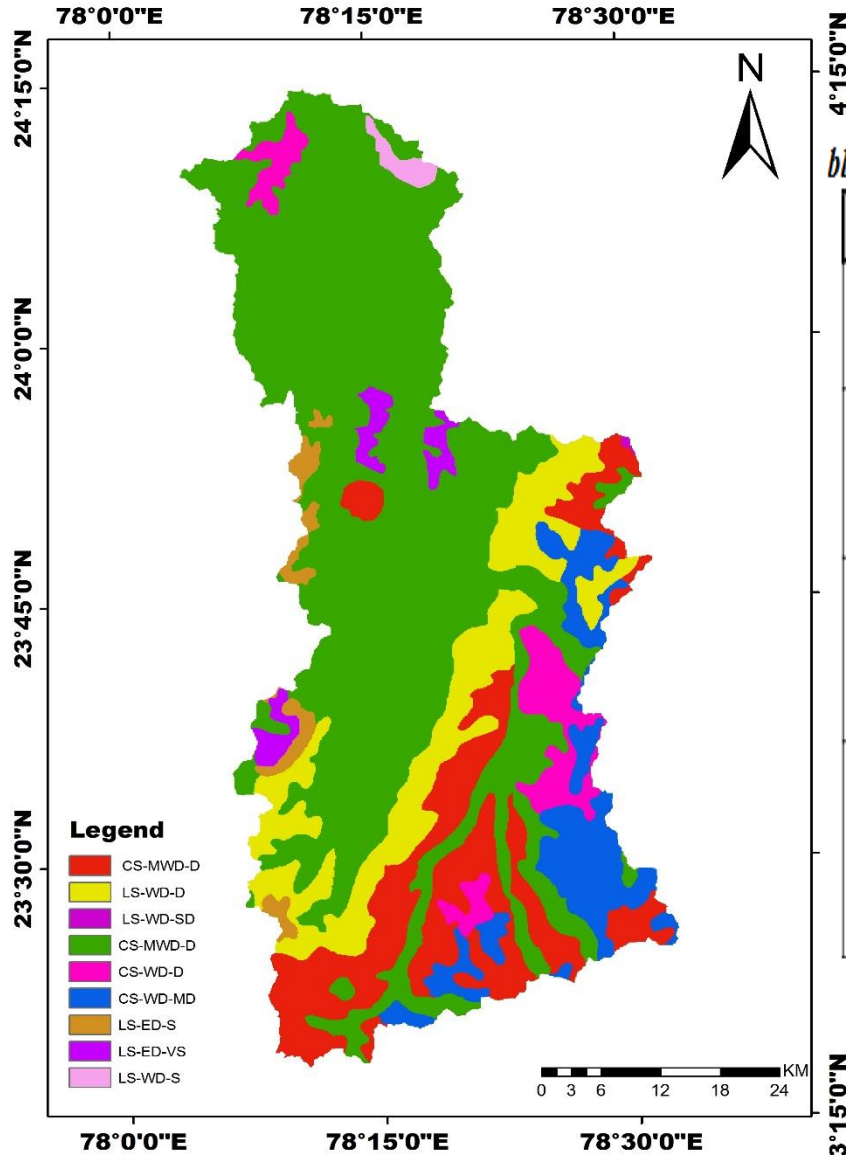

Table 6 Hydrologic soil groups information

HSG	Textures	Characteristics
A	Sand, Loamy Sand or Sandy Loam	Low runoff potential & high infiltration rates
B	Silt Loam or Loam	Moderate rate of infiltration (when thoroughly wet) & moderate rate of water transmission
C	Sandy Clay Loam	Slow rate of infiltration rate (when thoroughly wet) & slow rate of water transmission
D	Clay Loam, Silty Clay Loam, Sandy Clay, Silty Clay or Clay	High runoff potential & very low infiltration rates (when thoroughly wet) & very slow rate of water transmission

SNOW COVER AREA

Normalised Difference Snow Index

$$\text{NDSI} = \frac{\text{Visible Band} - \text{SWIR Band}}{\text{Visible Band} + \text{SWIR Band}}$$

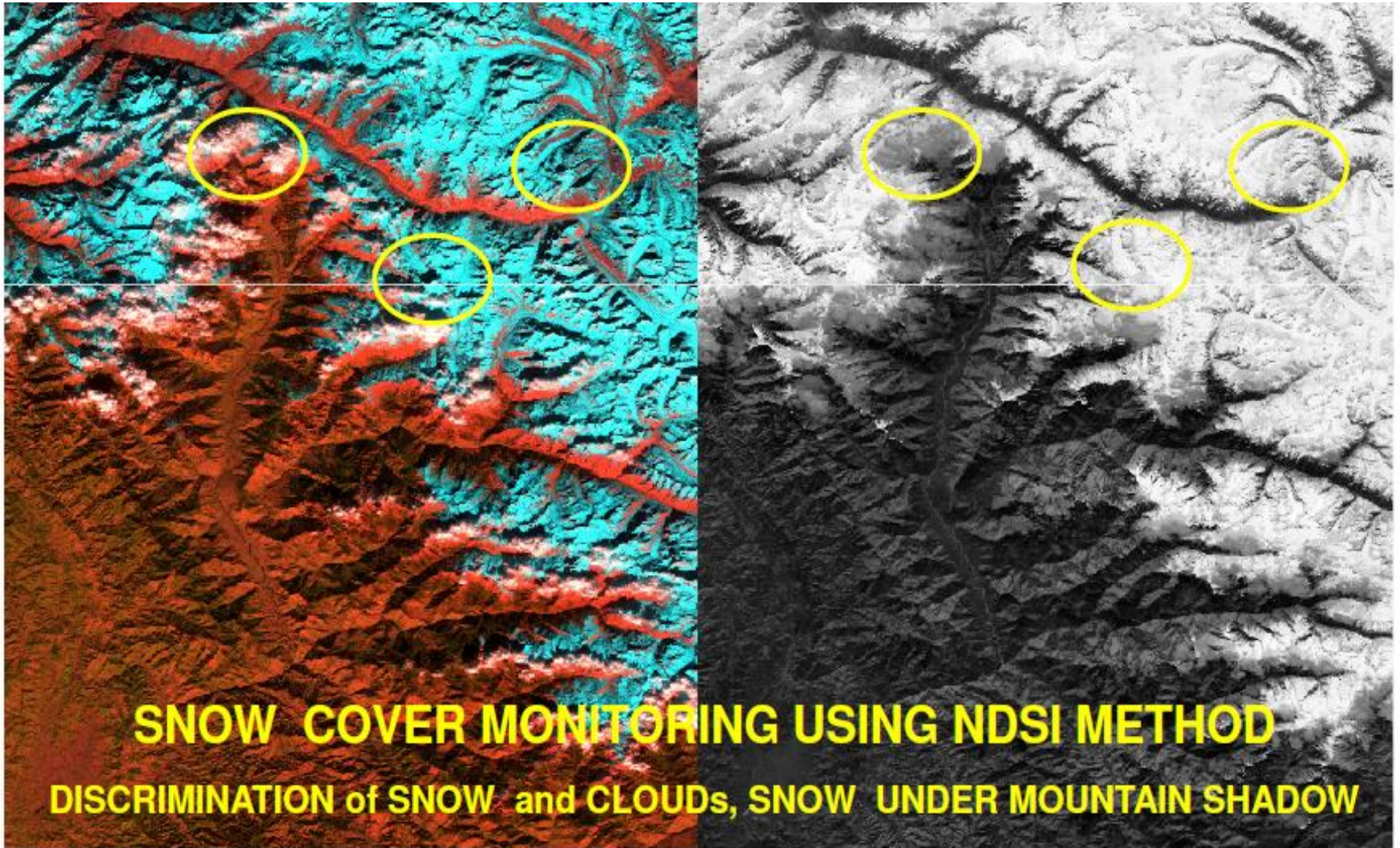

Snow cover area- NOAA-AVHRR Images (2004)

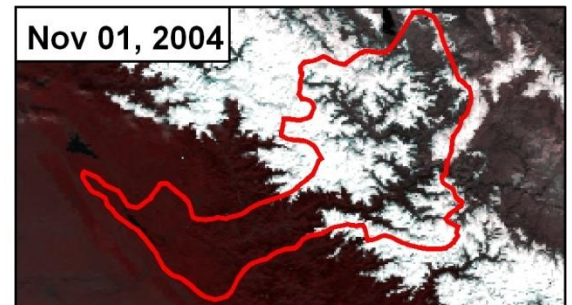
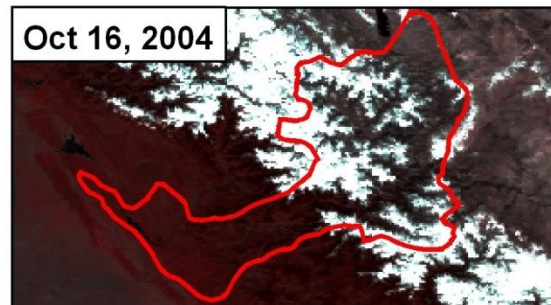
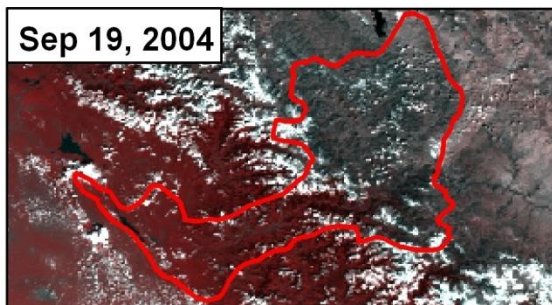
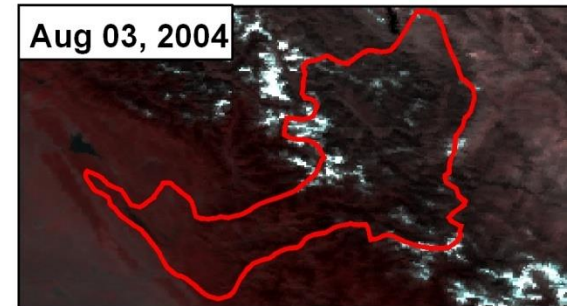
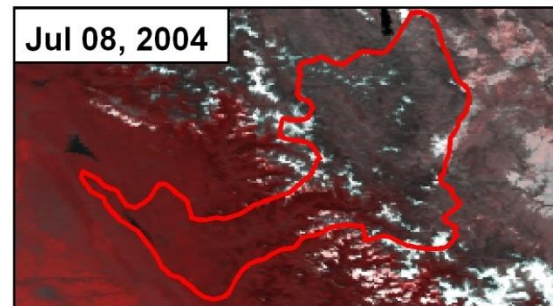
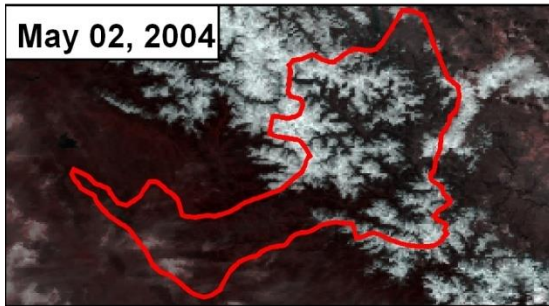
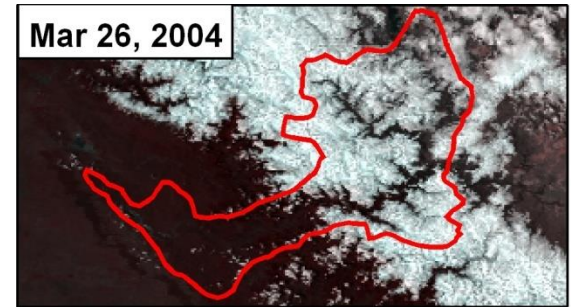
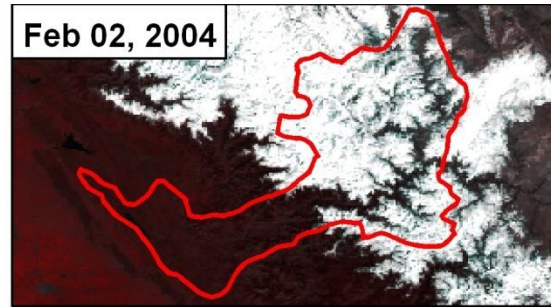
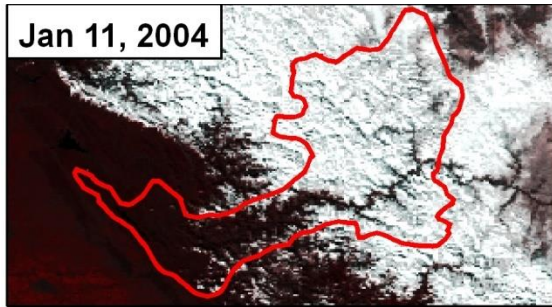

Satluj Basin



Channel-2



Channel-1



Channel-1

Retreating Imja glacier and growing glacial Lake



CORONA 15 DEC 1962



SPACE SHUTTLE DEC 1983



LANDSAT TM 1992



IRS ID PAN 19 MAR 2001



ENVISAT, ASAR, 18 October 2007



Quickbird Jan 2006



IRS LISS3 2005



GLACIAL LAKE AND GLACIAL LAKE OUTBURST FLOOD (GLOF)

Glacial dammed lakes are formed by accumulation of water from the melting of snow and ice cover and by blockage of end moraines.

Sudden breach of lake may generate the discharge of large volume of water and debris causing floods (GLOFs)

Impact of climate change is well observed in the Himalayan-Retreating Glaciers, Growing Glacial lakes, and-Glacial lakes Outburst Floods (GLOFs)



Monitoring Floods (contd..)

Non Flood Year (1988), TM 432



Flood Year (1993), TM 432

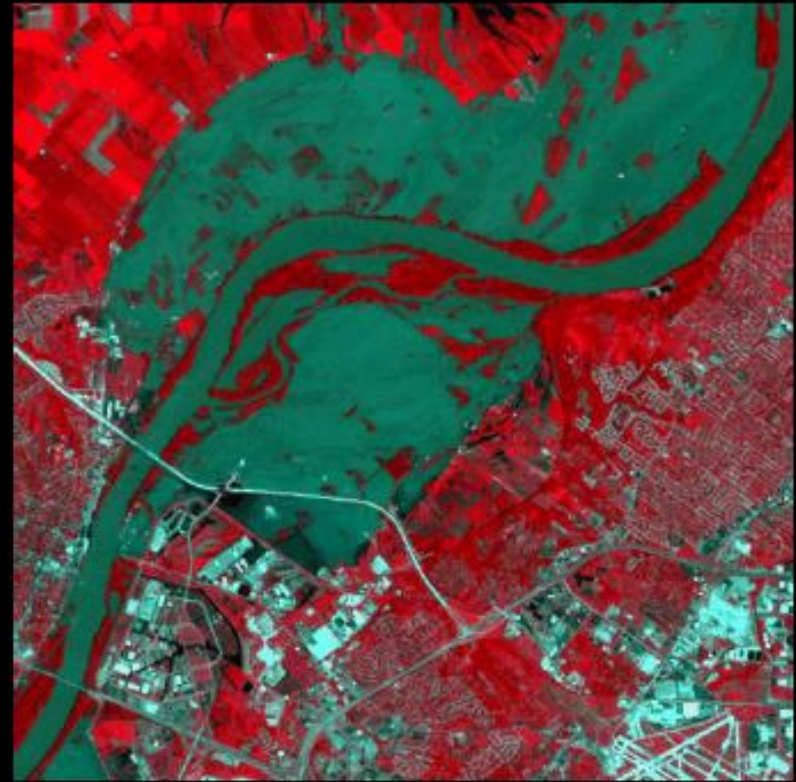

Prof. D. Nagesh Kumar, Dept of Civil Engg, IISc, Bangalore

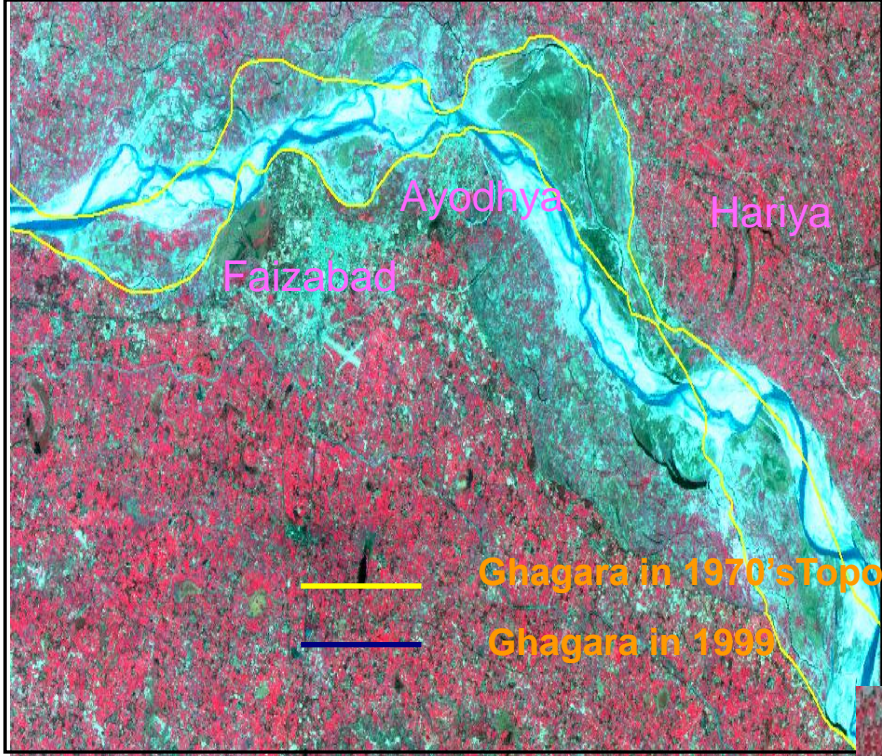

False Colour Composite (1999) overlaid by drainage from toposheet (Ghagara)



False Colour Composite (2003) overlaid by drainage from toposheet (Ghagara)

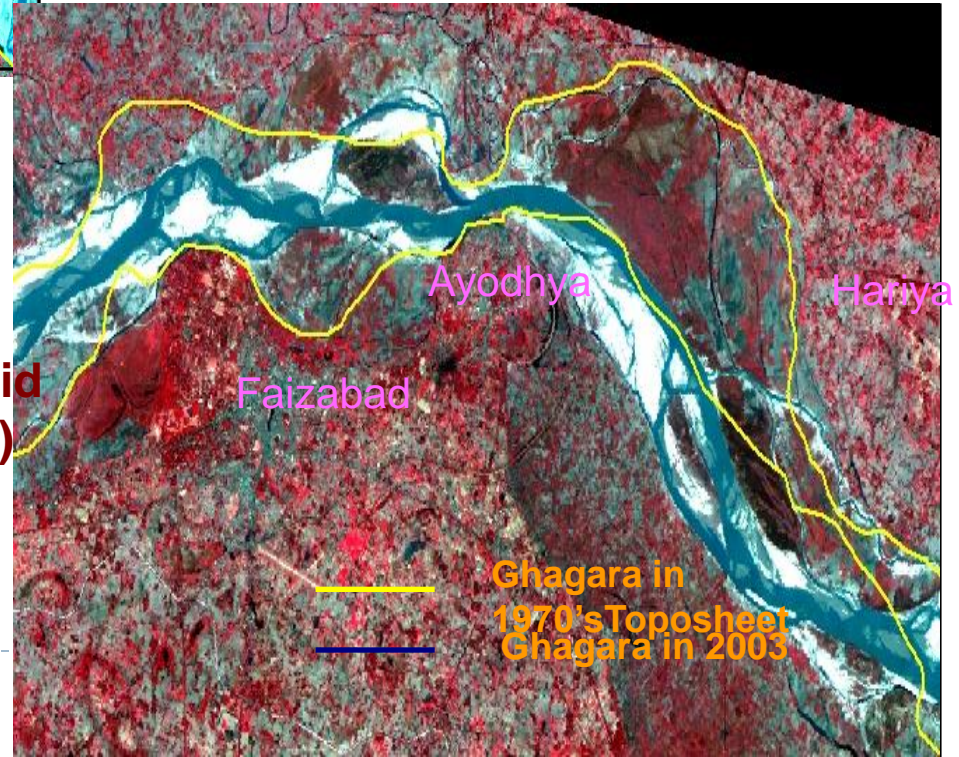

CASE STUDY



Flood Zoning / Mapping

- **River Bhagirathi at Uttarkashi**
- **River Ganga from Haridwar to Lakshar**



OBJECTIVES

The objective is to do flood plain zoning based on the modelling results for the characteristic discharges calculated for the both the stretches (flood frequencies of say 5yr, 10yr, 30yr, 50yr, 100yr return period).

The scope of work :

- **Preparation of Digital/Survey map of the river showing.**
- **Calculation of Characteristic flood discharges of the stream based on flood frequency analysis.**
- **Flood plain boundary in both the stretches.**
- **Preparation of digital/GIS map showing the defined flood plain boundary limit which shall be the guiding factor for any construction to the proposal near river banks.**



Study area

Two stretches falling in Ganga basin

- (i) Gangori to Bathedichungi
(length 10 km of river Bhagirathi)
- (ii) Haridwar to Laksar,
(length 50 kms of river Ganga)



Data Requirements

➤ Flood Mapping

- Satellite Images (pre and post flood of 2013)
- DEM (CartoSat DEM at 10 m resolution)

➤ Hydraulic Model

- Discharge data
- River cross section data (field survey)
 - cross sections & hydraulic structures: In-channel from field surveys and over bank from LIDAR
 - distance between cross-sections
- Surface Roughness (e.g. Manning's n)
- Upstream and downstream boundary conditions (flow, stage, rating curves, normal depth)

SOFTWARE USED

- ▶ ERDAS Imagine
- ▶ ArcGIS.
- ▶ HEC-GeoRAS
- ▶ HEC-RAS
- ▶ Statistical Tool



METHODOLOGY

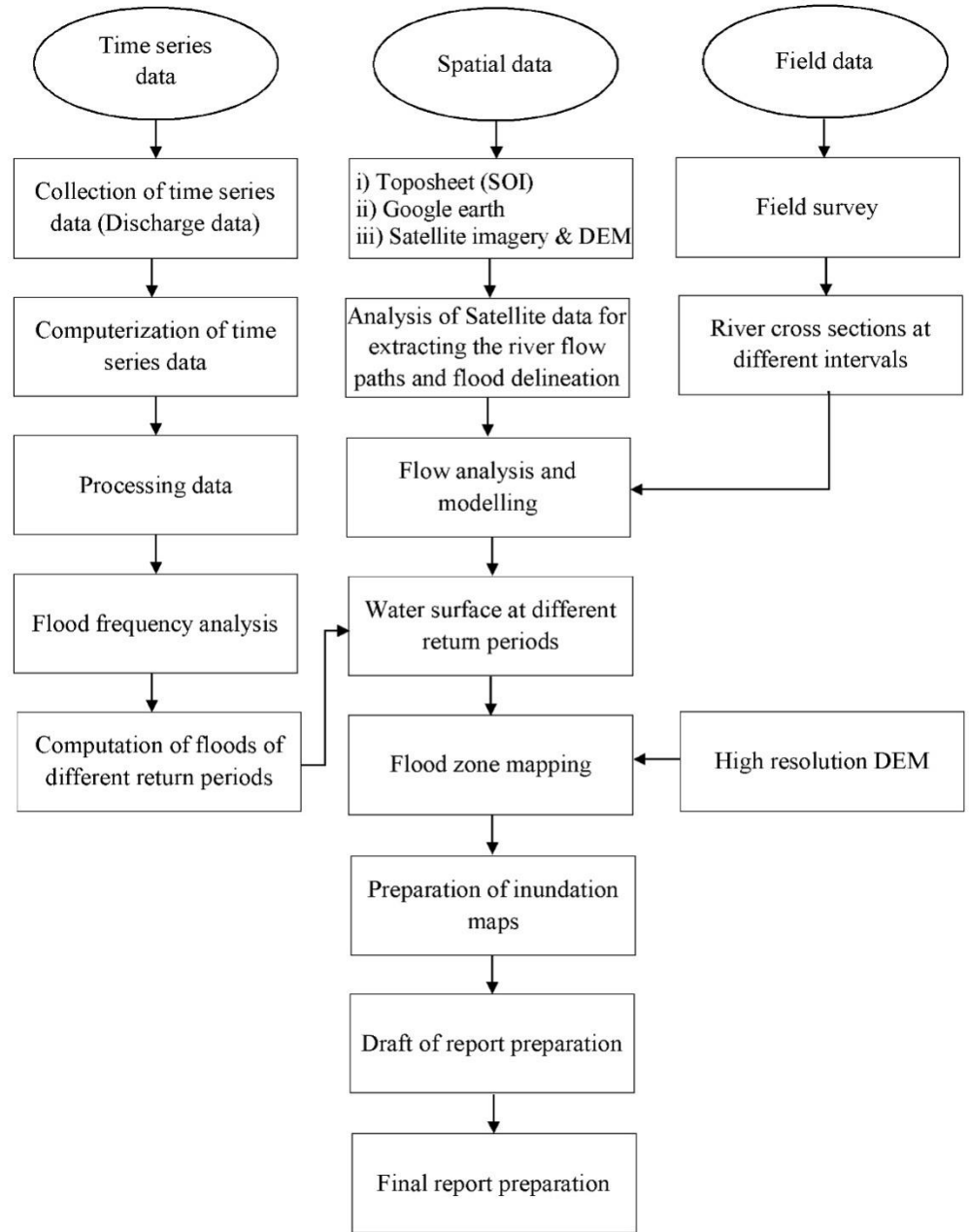
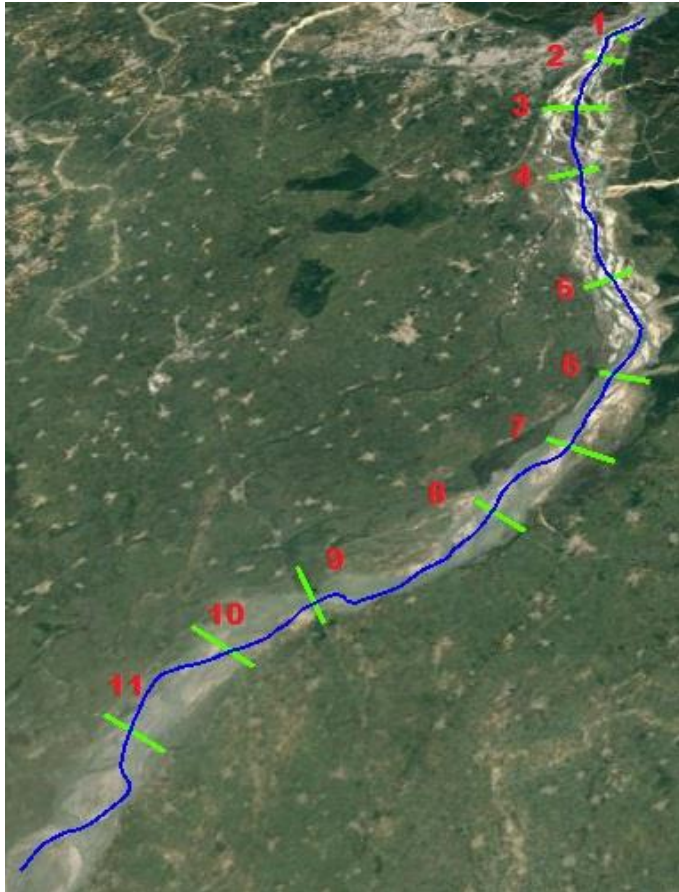

Location map (Haridwar stretch)

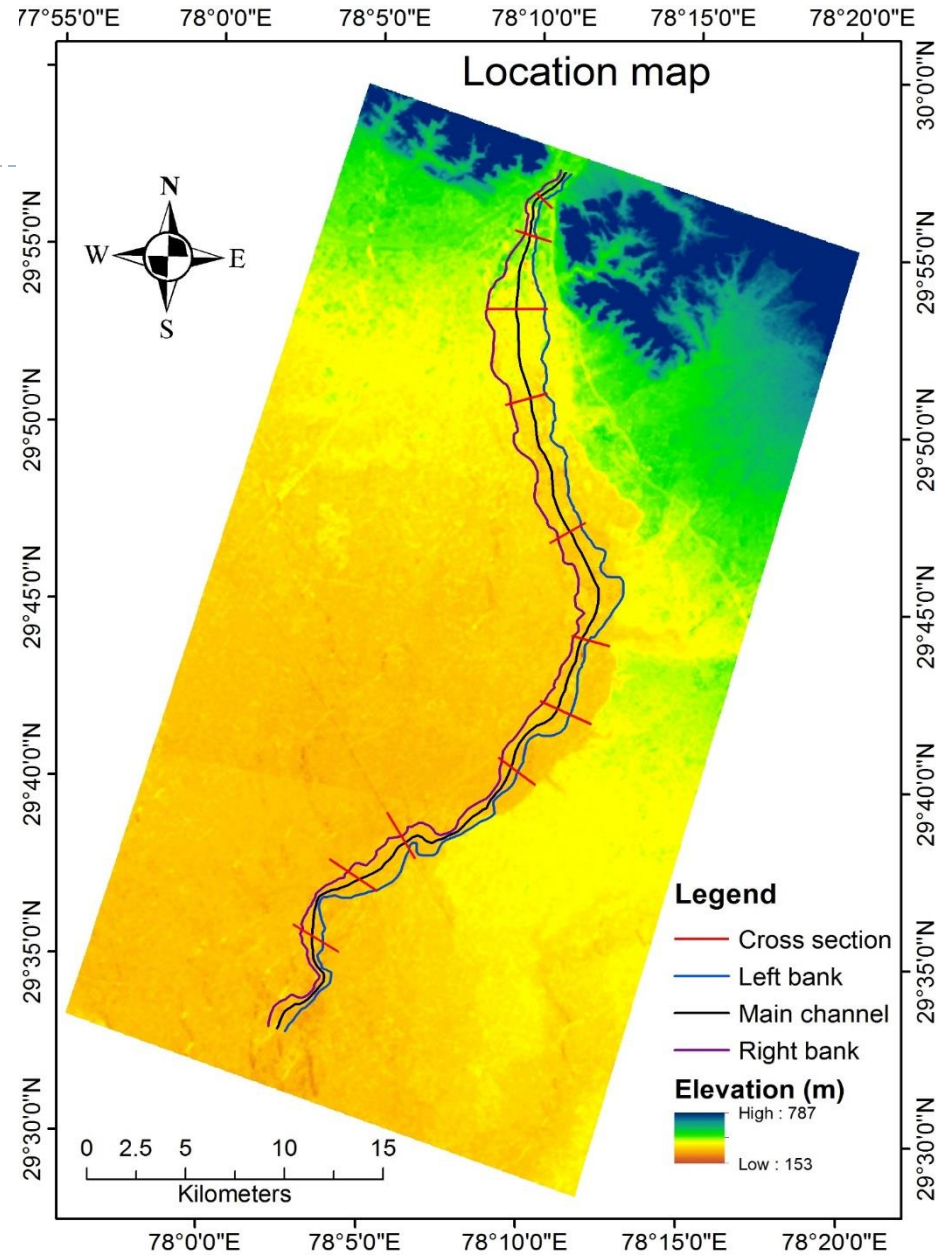

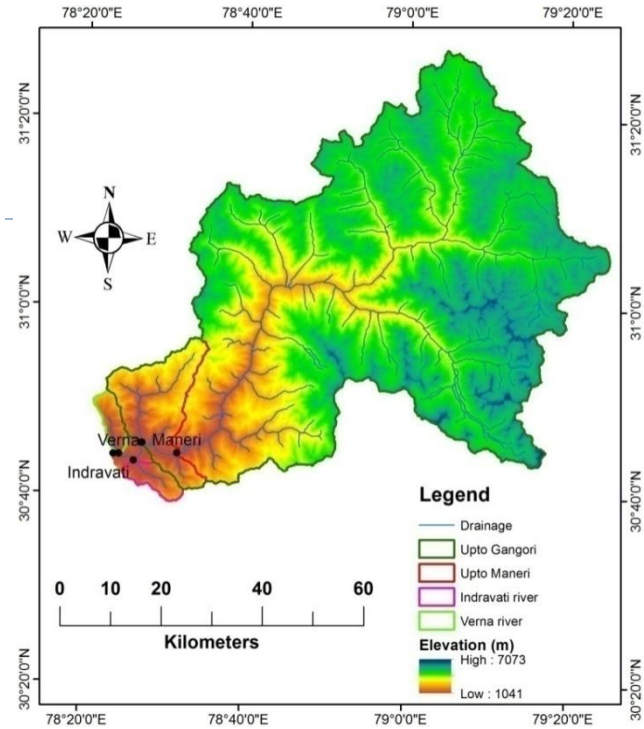
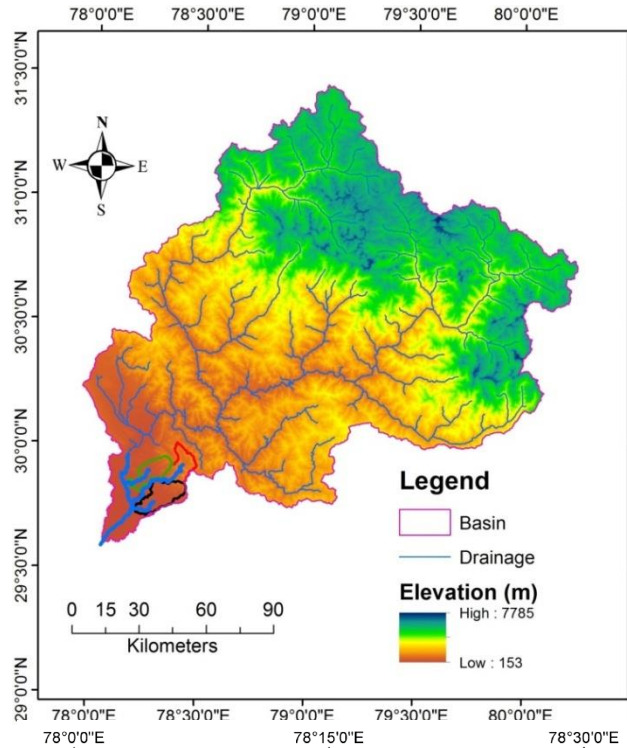

DEM

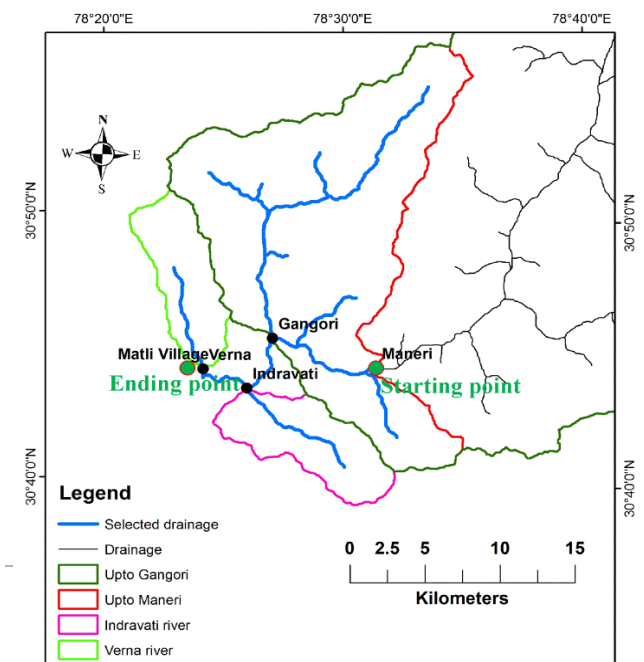
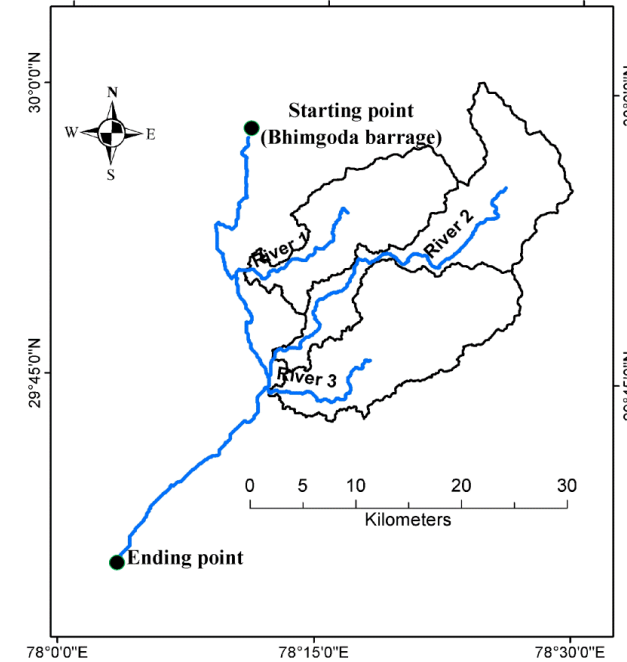

methodology for correction of DEM

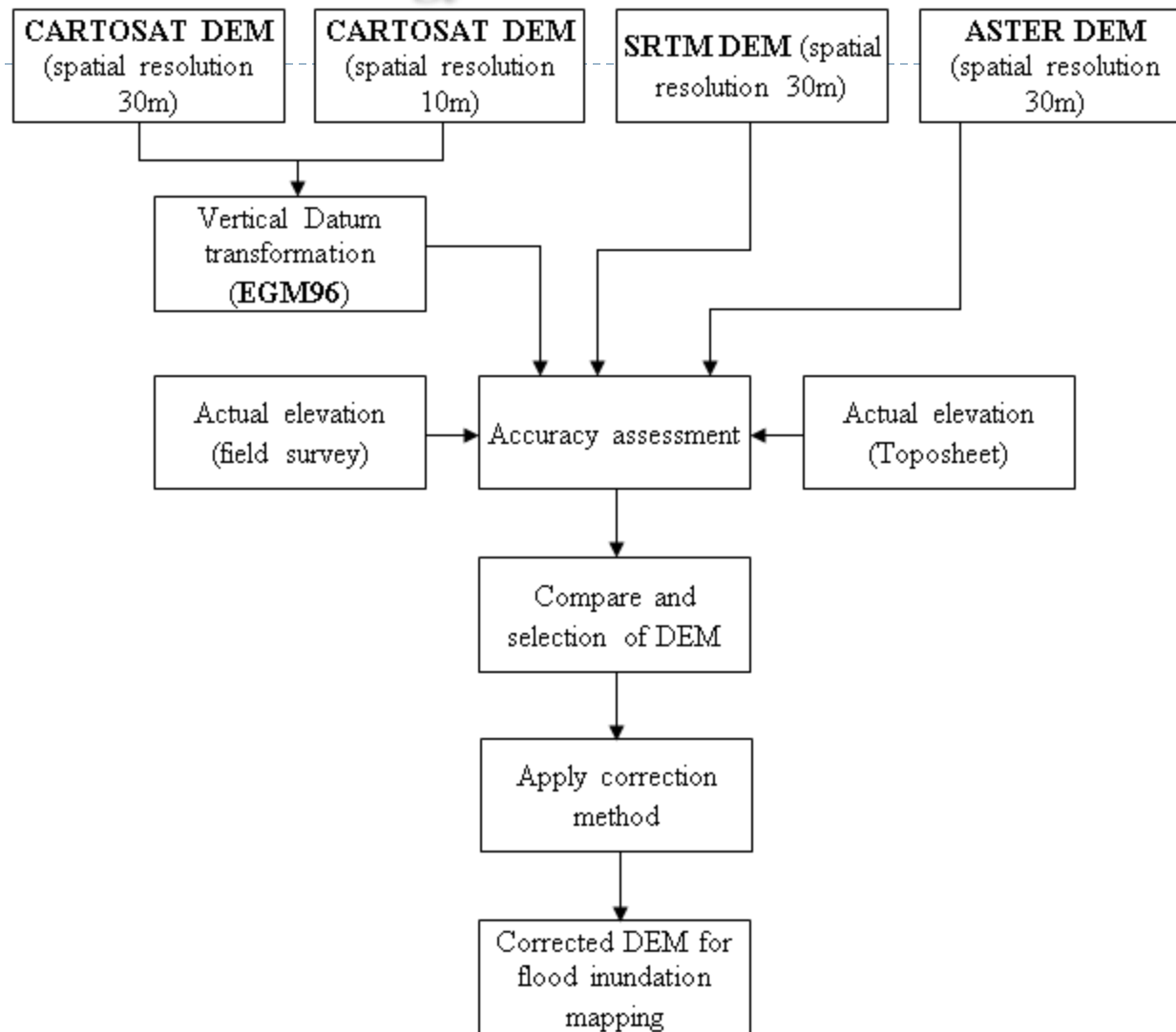

Flood extent as per Satellite data (Haridwar stretch)

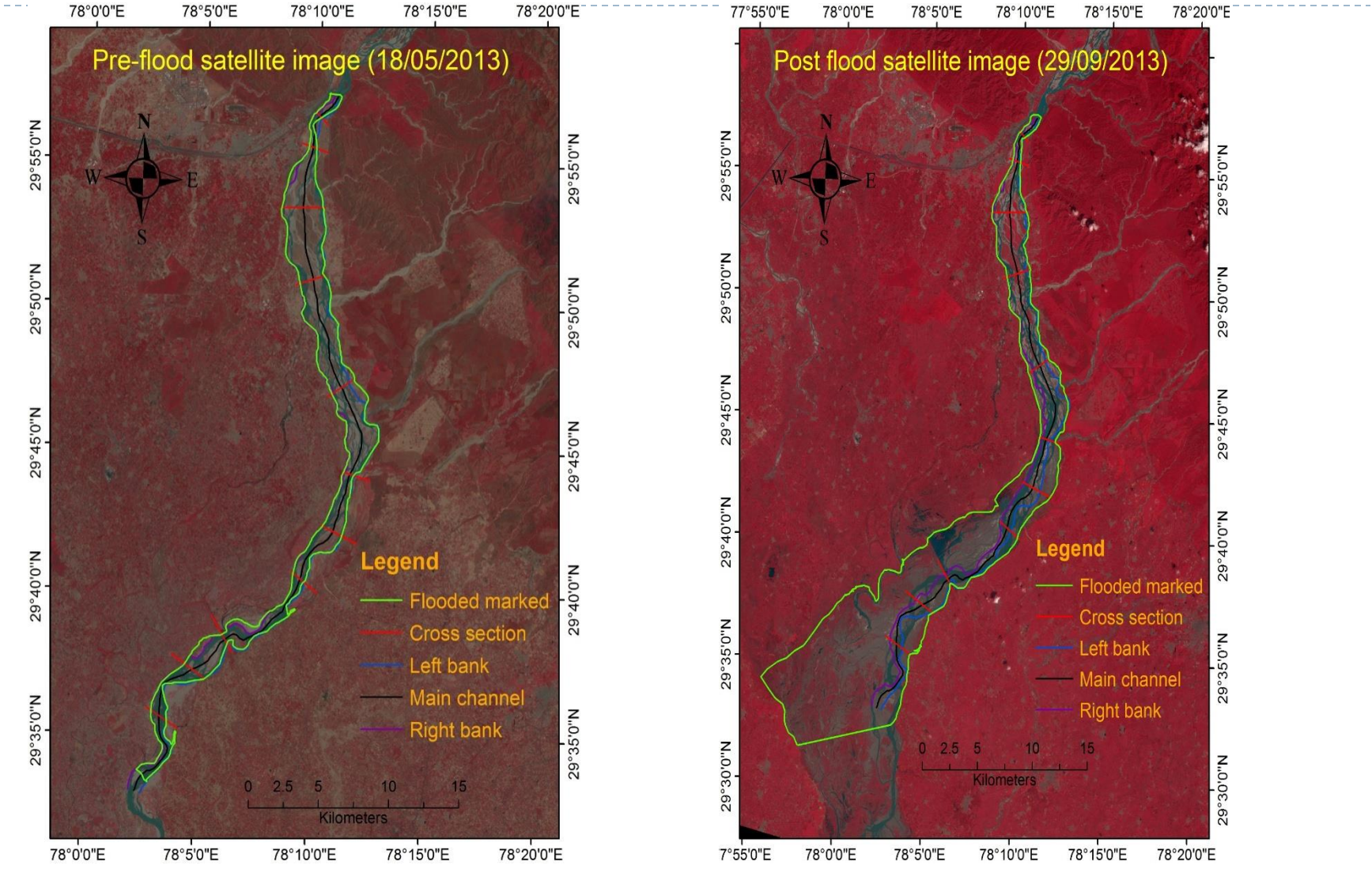

Cross sections from field survey (Haridwar area)

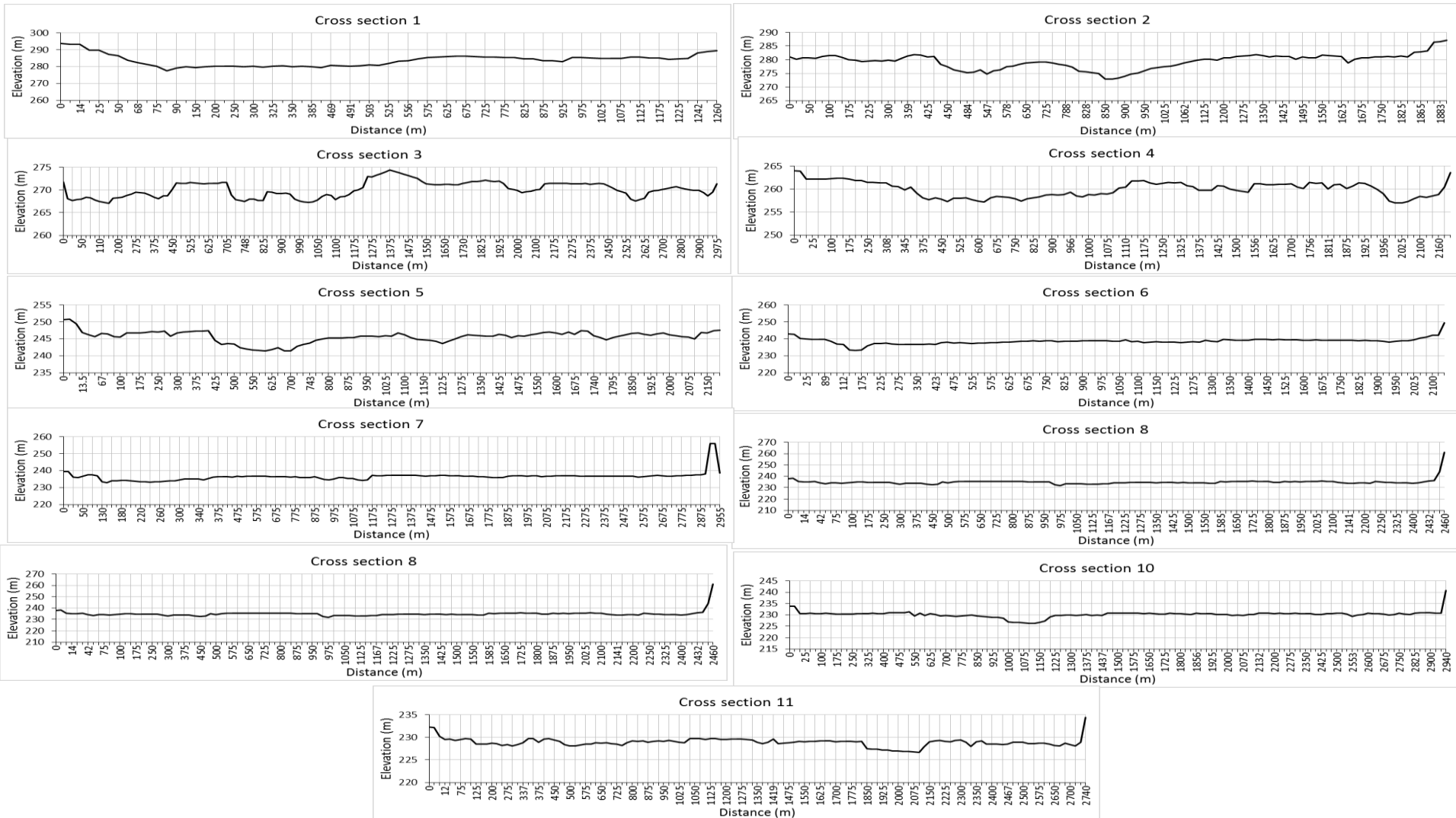

flood frequency analysis

- ▶ It is essential to interpret the past record of flood events in order to evaluate future possibilities of such occurrences.
- ▶ *statistical distributions*
- ▶ Normal
- ▶ Log Normal
- ▶ Gumbel
- ▶ **General Extreme Value**
- ▶ Pearson Type III
- ▶ **Log Pearson Type III**

Flood frequency analysis was performed in this study by selecting annual maximum discharge



Return period and flood values (Bhimgoda)

Return period (year)	Estimated Flood (m ³ /s) by	
	L-Moment based EVI Method	L-Moment based GEV Method
5	7477.17	7079.65
10	9027.88	8899.83
25	10987.21	11654.23
30	11371.07	12261.68
50	12440.75	14086.02
100	13883.56	16885.60

Error statistics

Distribution	ADA	ADR	Efficiency	D Index
EVI	0.09	0.01	0.94	1.1863
GEV	0.04	0.01	0.89	1.4911

Return period and flood values (Uttarkashi Upto Gangori)

Return period (year)	Estimated Flood (m ³ /s) by	
	L Moment based EVI Method	L Moment based GEV Method
5	1249.01	878.92
10	1580.14	1239.08
25	1998.52	2022.22
30	2080.48	2238.71
50	2308.89	2995.28
100	2616.98	4499.85

Error statistics for L Moment based distribution for flood frequency analysis

Distribution	ADA	ADR	Efficiency	D Index
EVI	0.37	0.18	0.55	6.127
GEV	0.07	0.01	0.85	2.697

Flood inundation mapping for 25 year return period

Flood inundation map of Uttarkashi stretch

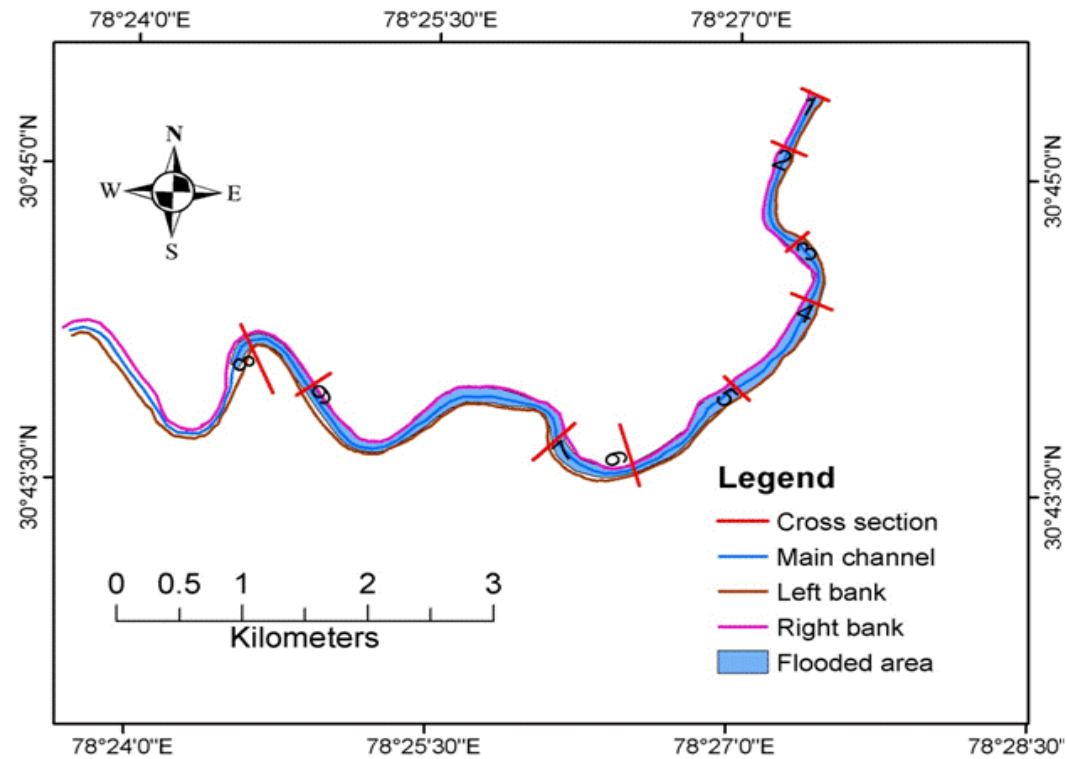
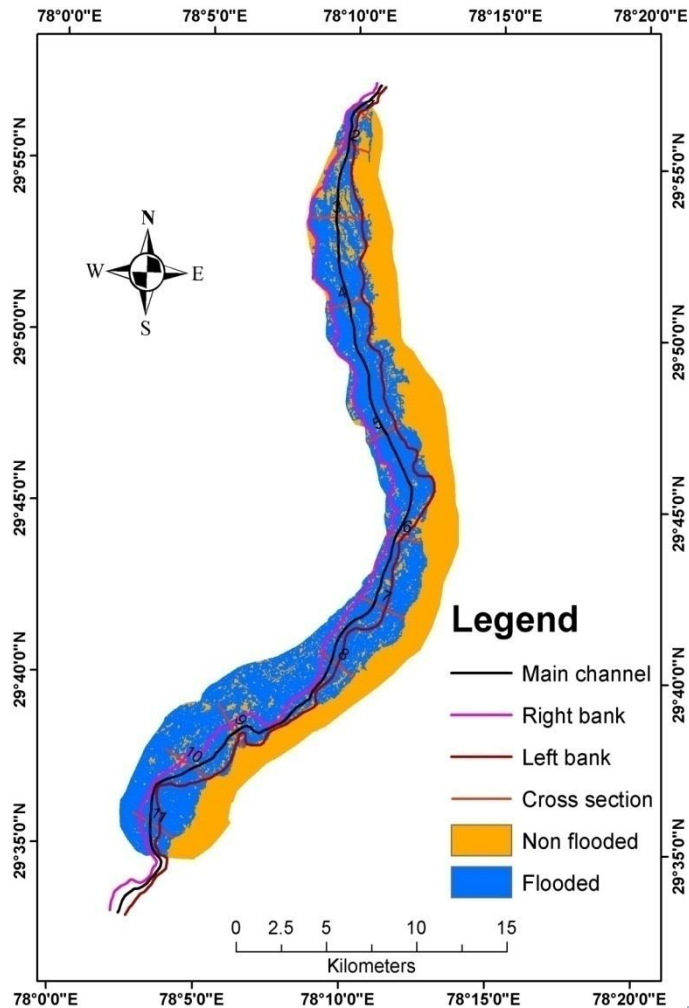

Flood inundated map of Haridwar stretch

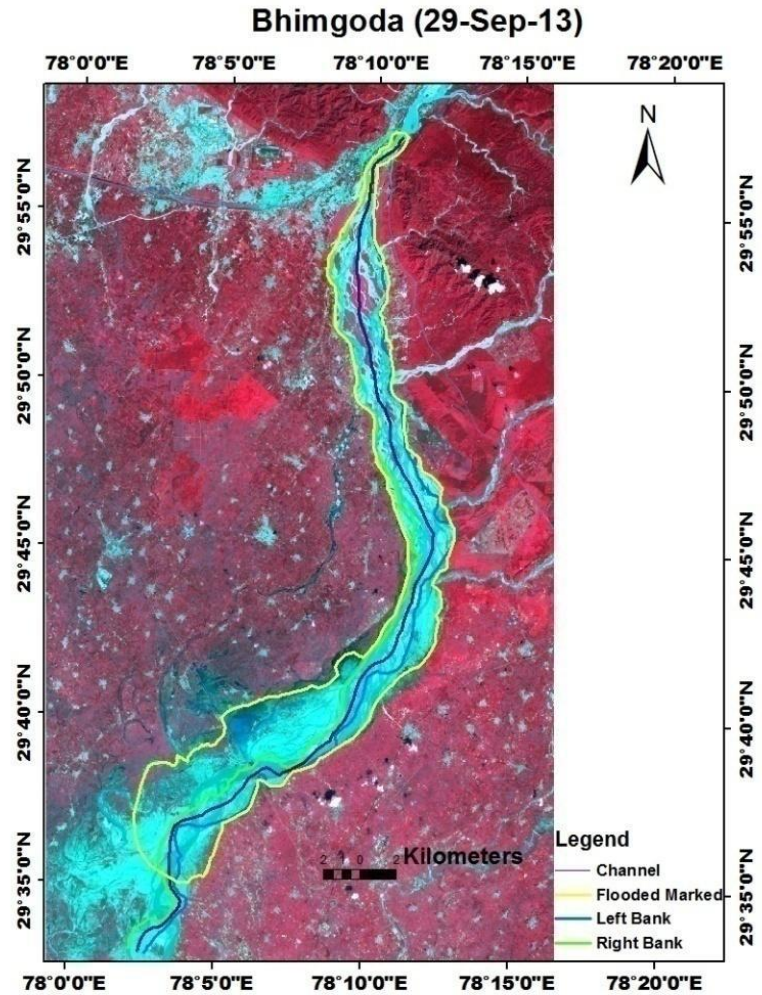

Conclusion

- ▶ Although flood is the most deadliest disaster still, but it has some benefits like:
- ▶ Recharge ground water
- ▶ Fresh water flood help in maintaining flood ecosystem
- ▶ Remote sensing and GIS plays an important role in Stormwater management





Thank
You