

Expert Testimony in Medico-legal Cases

Forensic Science



Dr. K.P.S Kushwaha
Ex-Senior Faculty
LNJN-NICFS (MHA, GOI)
Rohini, Delhi
kpsingh11@yahoo.com

Expert Testimony –Biological evidences

- Types of Biological Evidence Materials likely to be found at the SOC.
- Scientific aids at the SOC - presentation of relevant case studies.
- Forensic examination of evidence materials - Identification , characterisation , interpretation of results ,reporting formats .
- Appraisal of forensic reports during court proceedings - honourable lower courts, High courts and Supreme court.
- Demonstration of Kits - for Evidence Collection in Sexual assault cases.

Forensic Evidence

- Recovery of forensic evidence leads to speedy investigation and strengthens the likelihood of conviction at trial with harsher sentences.
- Cases with physical evidence are more likely to lead to arrest , be referred to the prosecutor , be charged, and result in conviction than cases without evidence.
- Forensic evidence as collected and analysed is unbiased .

In most of the crimes evidence materials are insufficient to link the criminal with the crime

*As a result culprit is acquitted or not brought to trial

* Sometimes innocent is convicted because of the insufficient evidence to exculpate him

*Justice is prompted by any development that allows courts to ascertain with increased precision who committed crime. DNA is one such development.

* Criminal justice system is required to use DNA information unless there are reasons not to do so.

Forensic Testimony

- A witness may testify only what he has experienced with his five senses .
- Testimony regarding his opinion is not allowed in legal system.
- However, testimony of the **expert witness** is permitted to offer his opinion pertaining to matters in dispute.

Expert witness

- Competent in any science, art, trade or occupation.
- Have developed skill or knowledge in a particular subject through education or experience so that he may form an opinion that will assist the fact finder.

- An expert witness can be anyone with knowledge or experience in a particular field or discipline **beyond that of a layman.**
- He uses his specialist knowledge to provide an opinion on an issue or facts in a case to help in resolving the litigation.

- Expert opinion is generally sought by one party, but the expert's overriding duty is to assist the court, and his report must be **independent, objective and unbiased**.
- No body can accurately claim to be an expert witness by profession, some are more competent than others.

- Report generated by the expert witness and the subsequent oral testimony should be based upon sound scientific practice, acceptable interpretation of the facts by vast majority of the scientific community and untainted by foreign interest.
- Objectivity and impartiality should be the guiding rules of an expert witness.

Blood as Forensic Indicator

- ❑ 13th Century: Chinese and Japanese used blood as forensic indicator
- ❑ For deciding issues of blood relations among individuals, they used to prick finger of concerned persons and allow the drops of blood to fall in a basin of water. If blood of both flowed together, they were declared blood-related.
- ❑ For deciding inheritor of dead person, drops of claimant's blood were allowed to fall on the bone of the deceased. If the blood soaked into the bone, he was declared the inheritor.

Such attempts appear quite illogical in the present context, however these were honest attempts for resolving issues and administration of justice

Biological Evidence Materials

- Blood/ Bloodstains
- Menstrual bloodstains
- Seminal stains
- Vaginal Secretion stains
- Saliva Stains
- Vomit
- Urine Stains

Cont....

- Faecal Matter
- Skeletal Remains
- Hair and Fiber
- Insects & Maggots
- Diatoms
- Vegetable Materials & Pollen grains
- Poisonous plants
- Microbes

Blood Constituent

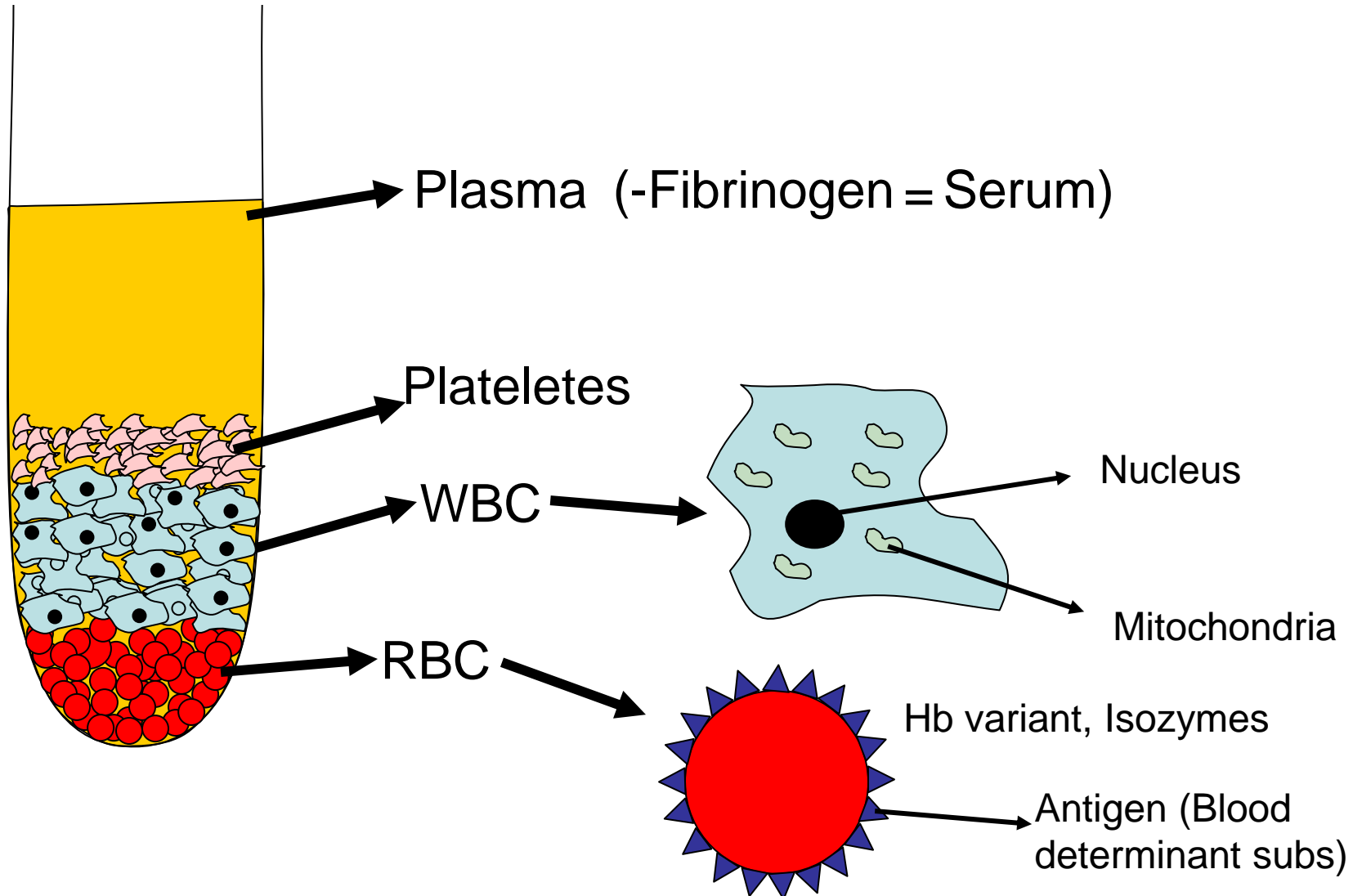

Blood Identification

- ❑ **Microscopic Identification of Cells** (*Nucleated RBC in vertebrate, chromatin bodies in WBC determine sex, sickle cell erythrocyte-person having sickle cell disease*)
- ❑ **Chemical Tests**
 - ❑ Catalytic tests (Presumptive)
 - Benzidine test
 - Phenolphthalein test
 - Leucomalachite test
 - Tetra-Methylbenzidine test
 - O-Tolidine
 - Luminol test
 - ❑ Crystal tests (Confirmatory)
 - Haemochromogen (Takayama, 1912) test
 - Haematin (Teichmann) test
 - Haemin (Wagenaar) test
- ❑ **Spectroscopic Identification**
- ❑ **Electrophoretic Identification** (*Hb fractions, HbS and HbC variants-racial origin*)
- ❑ **Immuno-Electrophoretic Identification** (*Blood=Hb+serum proteins, combination of Hb ring around the well and precipitin lines identifies blood and also its species*)
- ❑ **Chromatographic Identification** (*Stain extract applied on Whatman no.1, after ascending chromatography paper is dried in oven to deactivate any vegetable peroxidases. Under UV Haematin gives red fluorescence*)
- ❑ **Immunological Identification** (*AntiHb serum is used*)



Positive



Negative





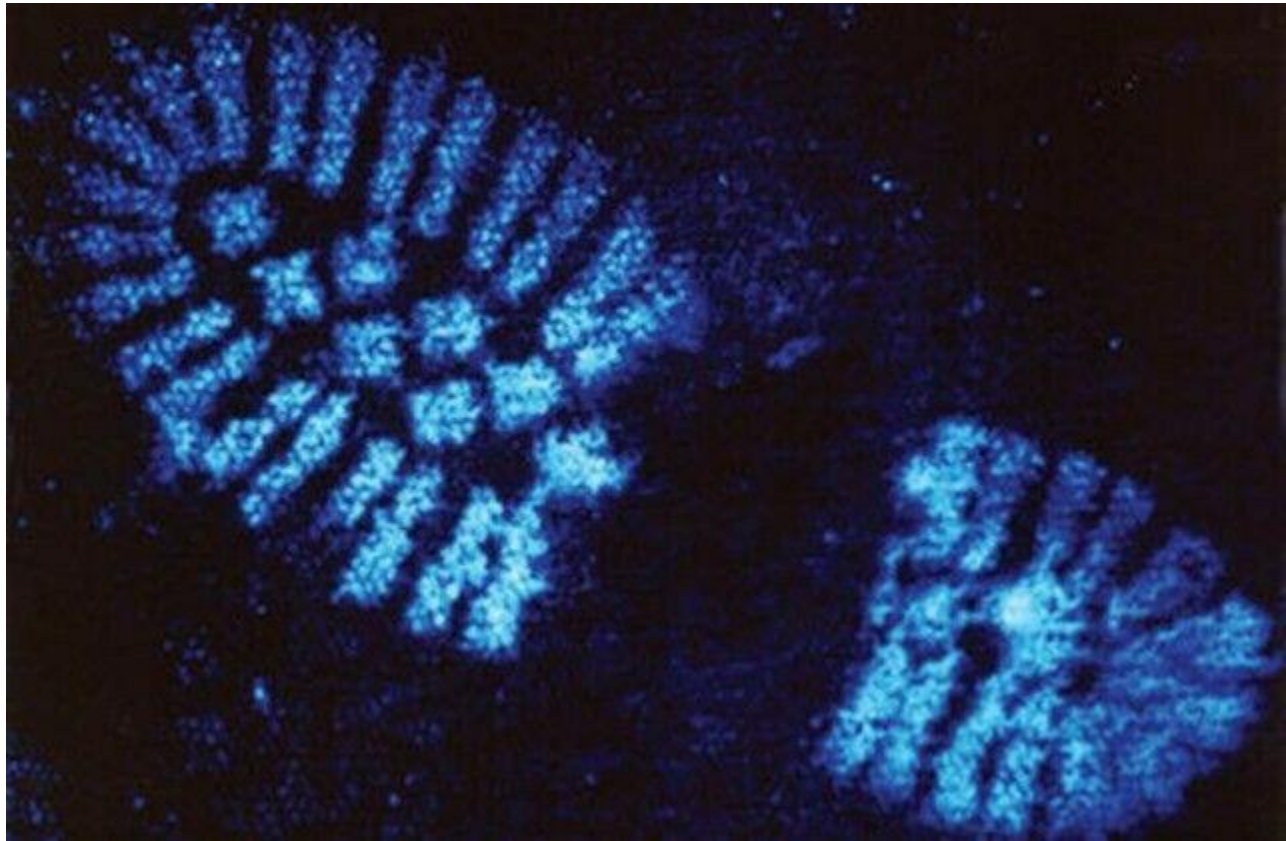



BLOODSTAINS

- Dried bloodstains are hard to remove.
- Blood does not adhere readily to swiftly moving metallic objects.
- It is very difficult & often impossible to detect blood on a bullet which has passed through a body.

Cont....

- Razors & sharp knife which have made a deep wound in a body may show little or no evidence of blood.
- Body of a woman sitting in a boat was cut nearly in half by blade of a plane flying low.
- No evidence of blood was detected on blades

Bloodstain Pattern

- Manner in which crime has taken place.
- Exact place of occurrence.
- Type of weapon used.
- Direction in which body was moved/transported .
- Whether the BSP on the suspect and his clothing is consistent with the crime scene.
- How many times the victim was hit.

Identification of Menstrual Blood

- Microscopic examination (Vaginal epithelium, desidual cells, endometrial cells)
- Fibrin degradation product determination
- LDH Isozyme

Identification of Seminal stains

➤ Physical Examination

➤ Presumptive Tests

- Acid Phosphatase Test

- Barberios Test (spermine*)

- Florence Crystal Test (Choline*)

* Combination of these found only in semen

➤ Confirmatory Test

- Sperm Detection

- Anti-P-30 (Semen specific glyco protein)

- LDH isozyme

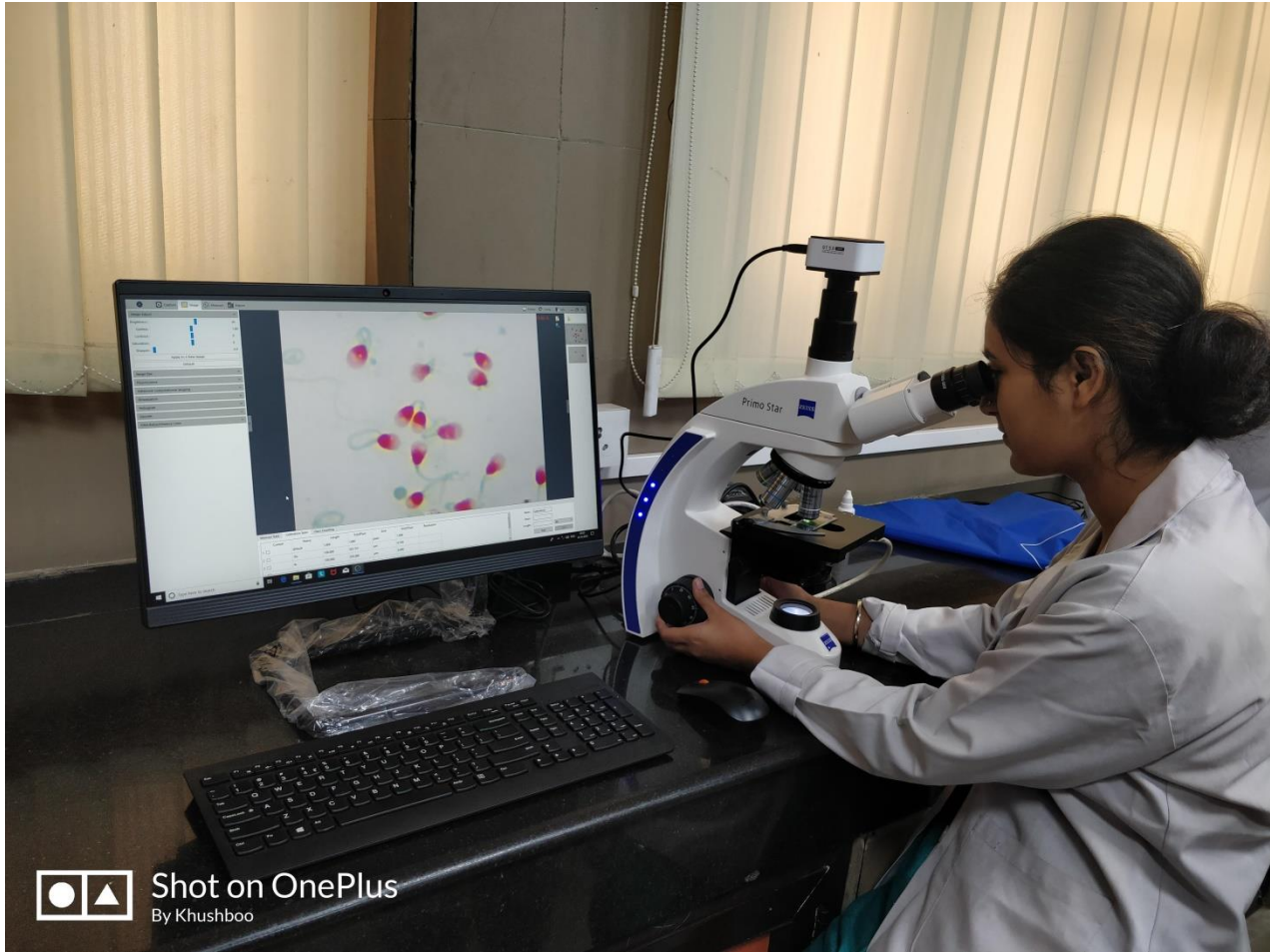

Shot on OnePlus
By Khushboo

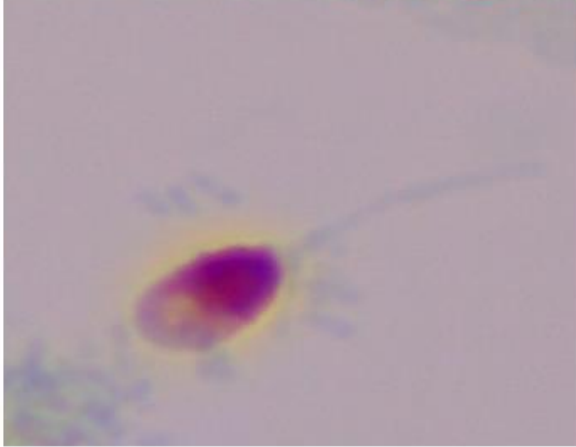
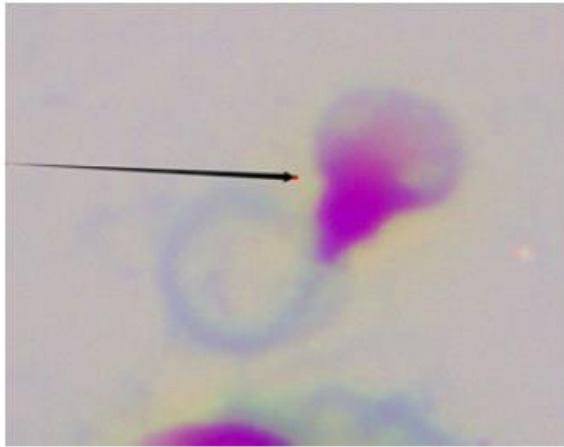
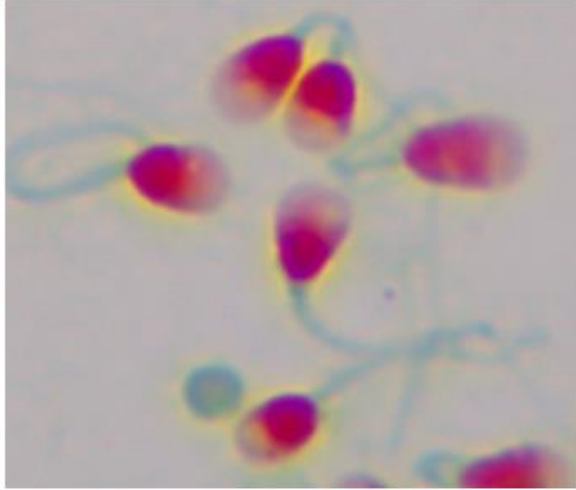
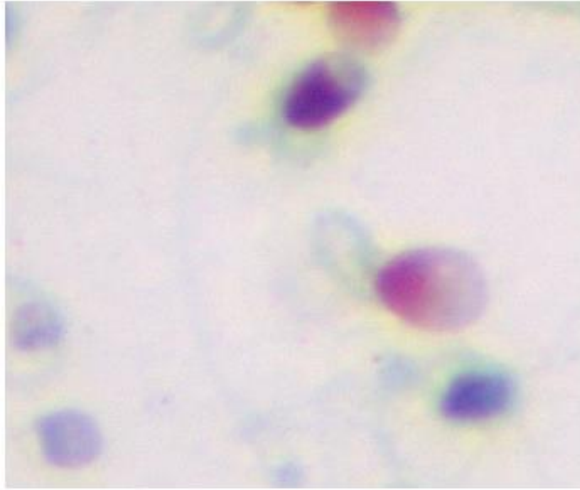







| PCP(Post Coital Period) | Positive | Negative | Yet to be verified with FISH |
|-------------------------|----------|----------|------------------------------|
| 1 day | 86 | 11 | 3 |
| 2 days | 39 | 9 | 0 |
| 3 days | 21 | 10 | 0 |
| 4 days | 35 | 13 | 2 |
| 5 days | 40 | 19 | 8 |
| 6 days | 19 | 13 | 1 |
| 7 days | 51 | 18 | 10 |
| 8 days | 12 | 15 | 9 |
| 9 days | 18 | 10 | 1 |
| 10 days | 41 | 24 | 7 |
| 11 days | 6 | 5 | 2 |
| 12 days | 15 | 6 | 4 |
| 13 days | 16 | 3 | 1 |
| 14 days | 12 | 5 | 2 |
| 15 days | 37 | 22 | 11 |
| 16 days | 6 | 4 | 2 |
| 17 days | 6 | 3 | 1 |
| 18 days | 3 | 3 | 1 |
| 19 days | 3 | 1 | 1 |
| 20 days | 7 | 12 | 7 |
| 21 days | 3 | 2 | 1 |
| 22 days | 0 | 2 | 0 |
| 23 days | 3 | 1 | 2 |
| 24 days | 1 | 2 | 0 |
| 25 days | 2 | 3 | 0 |
| 26 days | 1 | 1 | 0 |
| 27 days | 1 | 2 | 1 |
| 29 days | 1 | 0 | 0 |
| 30 days | 8 | 6 | 4 |
| 31 days | 1 | 1 | 0 |
| 32 days | 1 | 0 | 0 |
| 35 days | 0 | 1 | 0 |
| 60 days | 1 | 1 | 0 |

RSID-Semen Test:

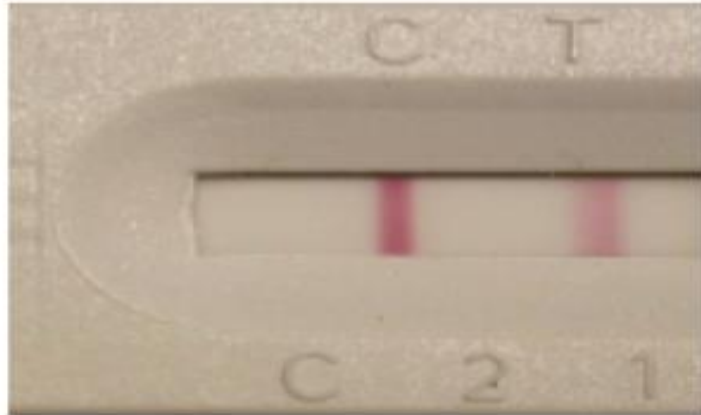

**Positive Result
(Human semen at
10000-fold dilution)**

ABAcad p30 Test:



**Positive Result
(Human semen at
10000-fold dilution)**

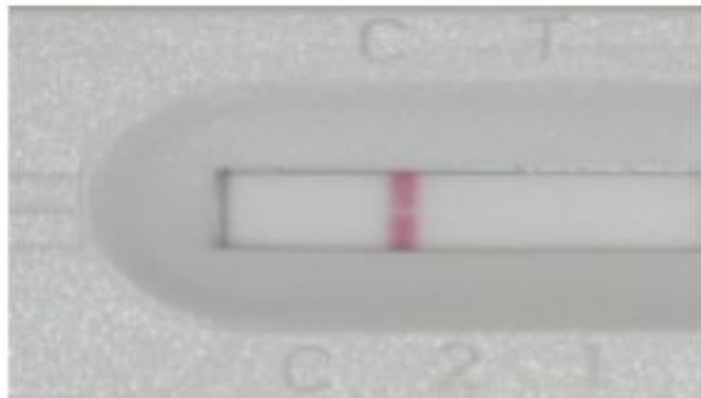

**Negative Result
(Pig Semen)**



**Negative Result
(Pig Semen)**

Fig. 1. Positive and negative results obtained from RSID-Semen Test and

Examination of Saliva Stains

- Test for Amylase
 - Starch iodine test
 - Radial gel diffusion

- LDH Isozyme

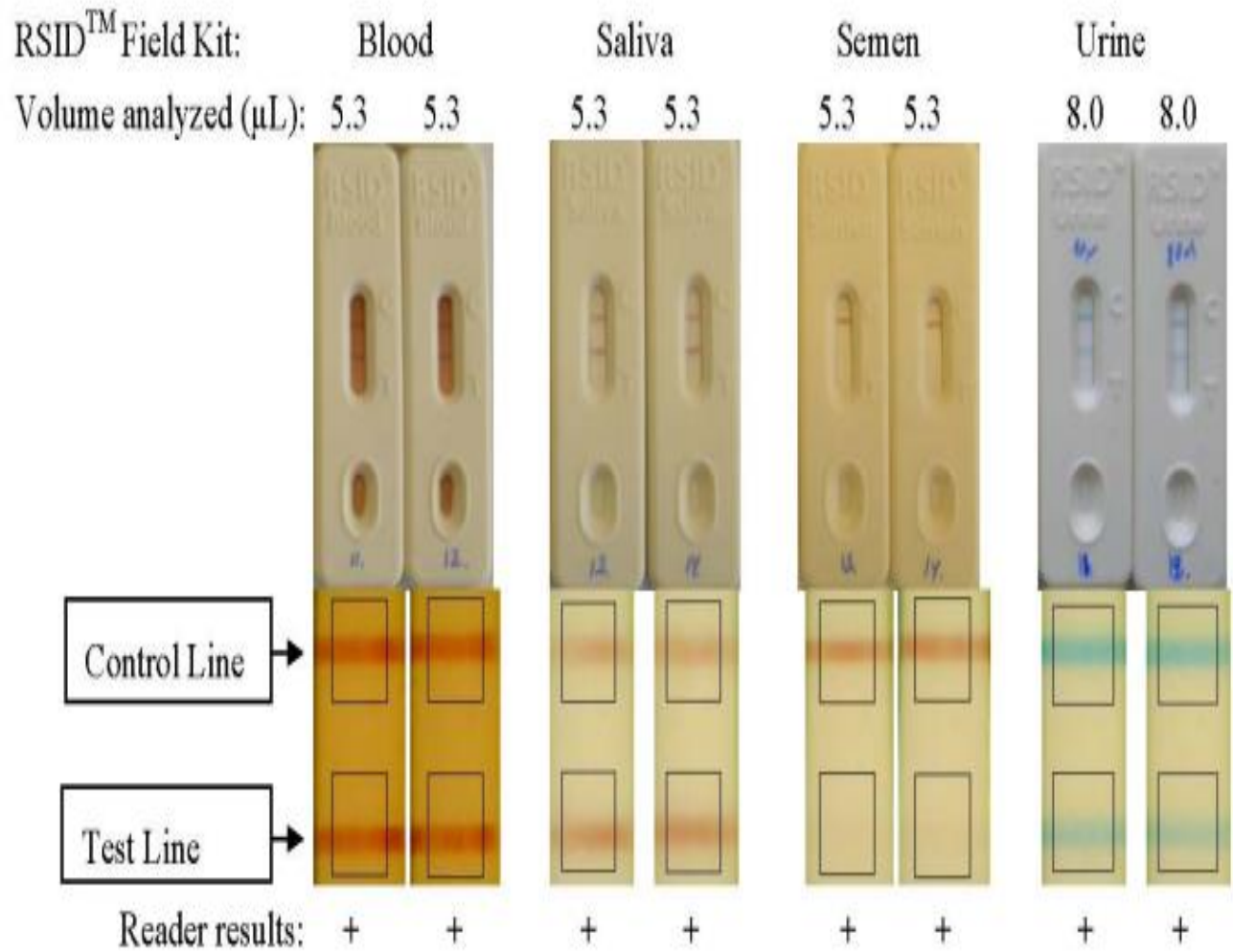

Examination of Vomit

- Mucus
- Free HCL
- Endothelial cells

Examination of Skeleton

- Species of origin
- If Human
 - Sex
 - Age
 - Stature
 - Identification of person by photo-superimposition technique

Superimposition technique for skull identification

The craniofacial superimposition technique is still an important way of identifying skulls in situations when:

- there is no reference sample for a forensic DNA analysis
- DNA typing from remaining tissue samples has failed
- ante mortem dental records are not available.

A



B

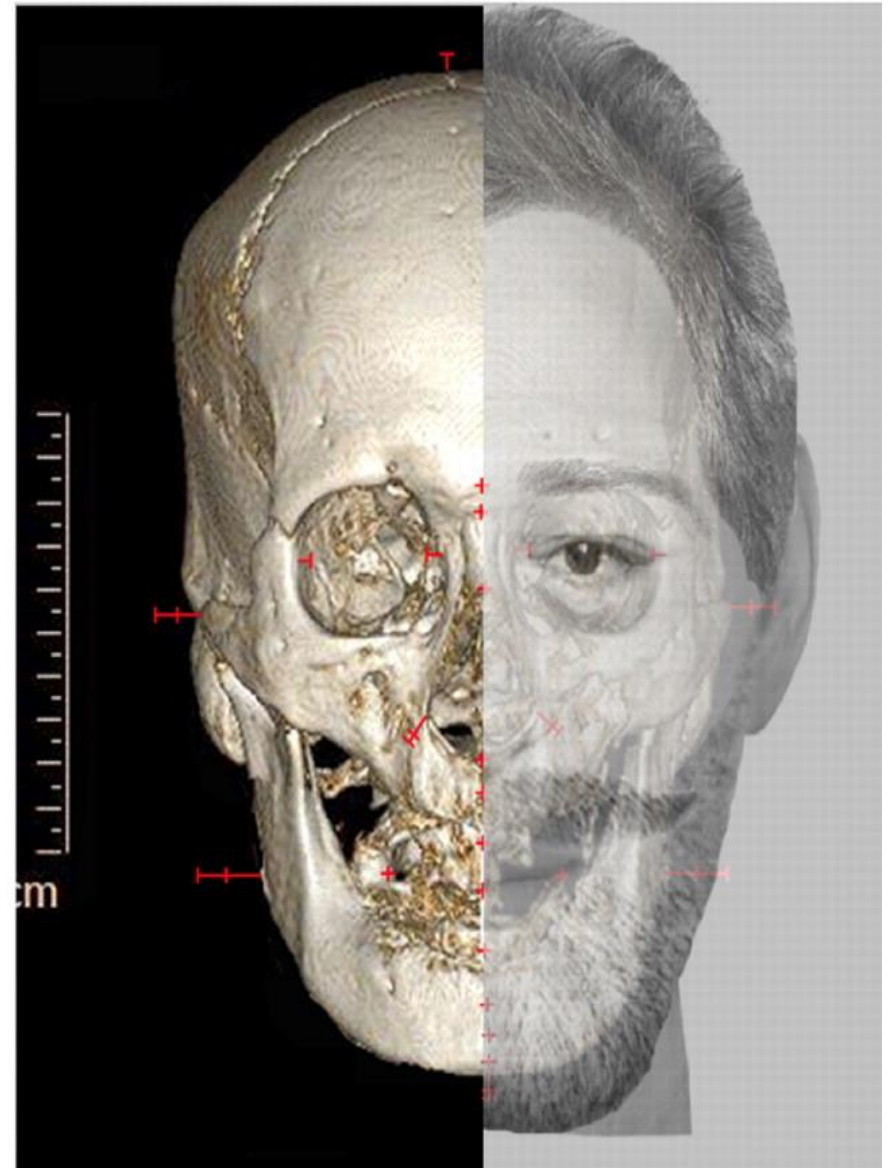

Examination of Faecal Matter

- **Physical Appearance** (Generally brown due to Urobilinogen, in infants yellow due to Bilirubin and milk diet)

- **Microscopic Examination**
 - Moistened in DW on slide + Iugol's iodine, put cover slip, examine for undigested food particles, vegetables material, muscle fibers

- **Confirmatory Test**
 - **Urobilinogen Test**

Based on detection of Urobilinogen (formed in intestine by reduction of bilirubin)

 - Stain extract + 40% Mercuric Chloride in Methanol + Amyl Alcohol, shake and centrifuge. Examine supernatant under long wave UV. No fluorescence at this stage.
 - Add 40% Zinc Chloride in Methanol. Shake and incubate at RT for 30-60min. Examine under long wave UV. Green fluorescence is positive test for Urobilinogen indicative of the presence of faecal matter.

Examination of Hair and Fibre

- Determination of species, sex, race, site (scalp, pubic, vulvar, chest, beard, axillary, eyebrow, limb, ear, anal), genetic markers (source by comparison)
- Fiber Examination – Identification of common textile fiber is done by
 - Microscopical examination
 - Staining test
 - Solubility test
 - Floatation test
 - Burning test
 - Physical test like direction of twist

Adult female blow flies arrive within minutes to lay eggs on a cadaver. Each deposits about 250 eggs in the natural openings of the body and open wounds. The eggs hatch into first-stage maggots within 24 hours. These feed and then molt into second-stage maggots, which feed for several hours, and then molt into third-stage maggots. Masses of third-stage maggots may produce heat, which can raise the temperature around them more than 10° C. After more feeding, the third-stage maggots move away from the body and metamorphize into adult flies.

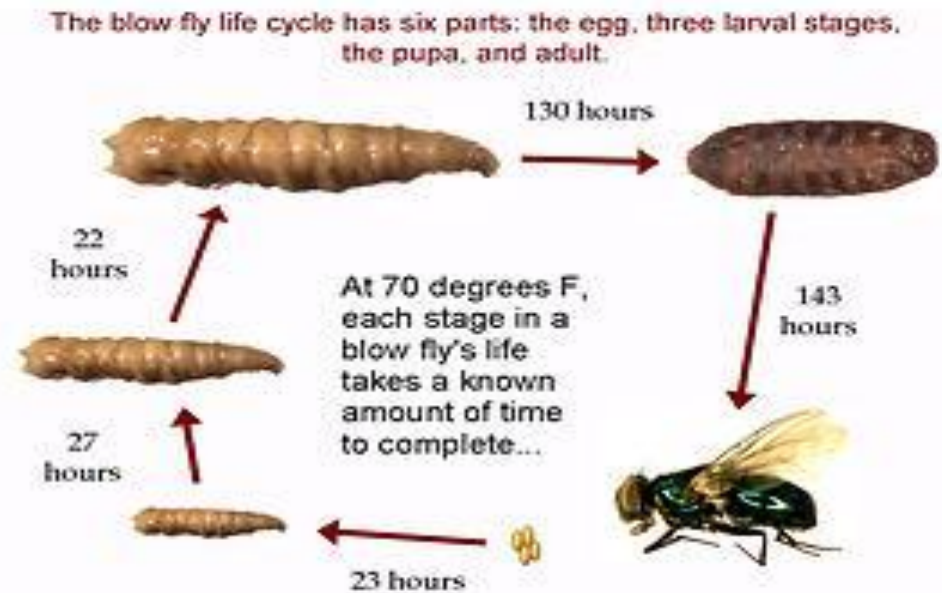

Examination of Diatoms

- ❑ Diatoms are aquatic unicellular plants having rigid coating of silica found in lakes, rivers, oceans, seas ditches and soil.
- ❑ Over 10,000 different species of diatoms differing in shape, size and design have been reported
- ❑ In drowning cases diatoms enters the blood streams through lungs and are carried to brain, liver, bone marrow etc.
- ❑ Diatoms can reveal the place of drowning and in highly putrefied bodies where others signs of drowning are not visible, establish the cause of death.

DIATOMS

Domain : *Eukaryota*

Kingdom : *Chromalveolata*

Phylum : *Heterokontophyta*

Class : *Bacillariophyceae*

- Diatoms are phytoplankton (microscopic algae).
- They are extremely widespread and occur as the dominant organisms of many diverse habitats.
- They are particularly conspicuous in both marine and freshwater bodies..

Order : Centrales

Family: Coscinodisceae



Genus : *Coscinodiscus*
Species : *radiatus*



Genus : *Coscinodiscus*
Species : *granii*

Order : Centrales

Family: Actinodisceae

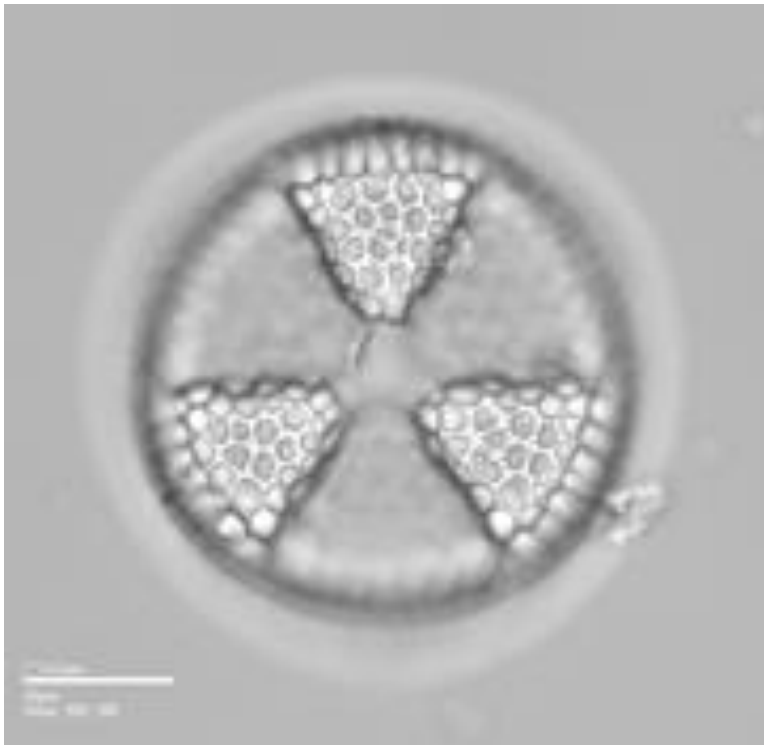

Genus : Actinoptychus
Species : senarius

Family: Eupodiscaeae



Genus : Auliscus
Species : sculptus

Order : Centrales

Family: Solenieae



Genus : Rhizosolenia

Family: Chaetocereae



Genus : Chaetocereae

Species : debilis

Order : Centrales

Family: Biddulphiaeae



Genus : Triceratium
Species : pentacrinus

Family: Euodieae



Genus : Hemidiscus
Species : cuneiformis

Order : Centrales

Family: Anauleae



Genus : Eunotogramma

Species : marinu

Order : Pennales

Family: Tabellarieae

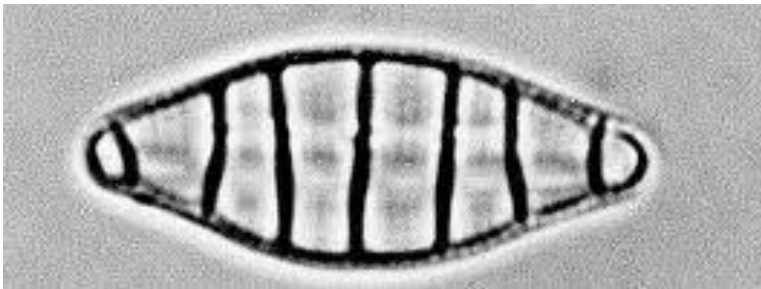
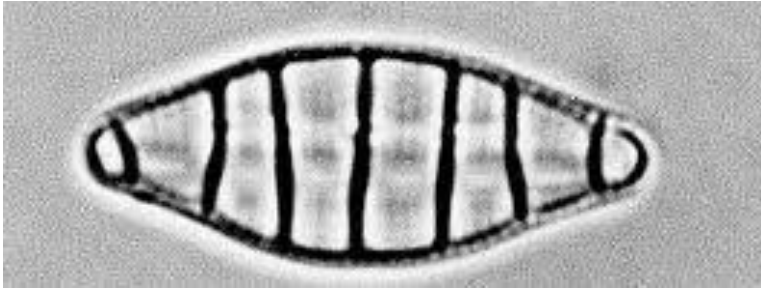

Genus : Denticula
Species : tenuis

Family: Meridioneae

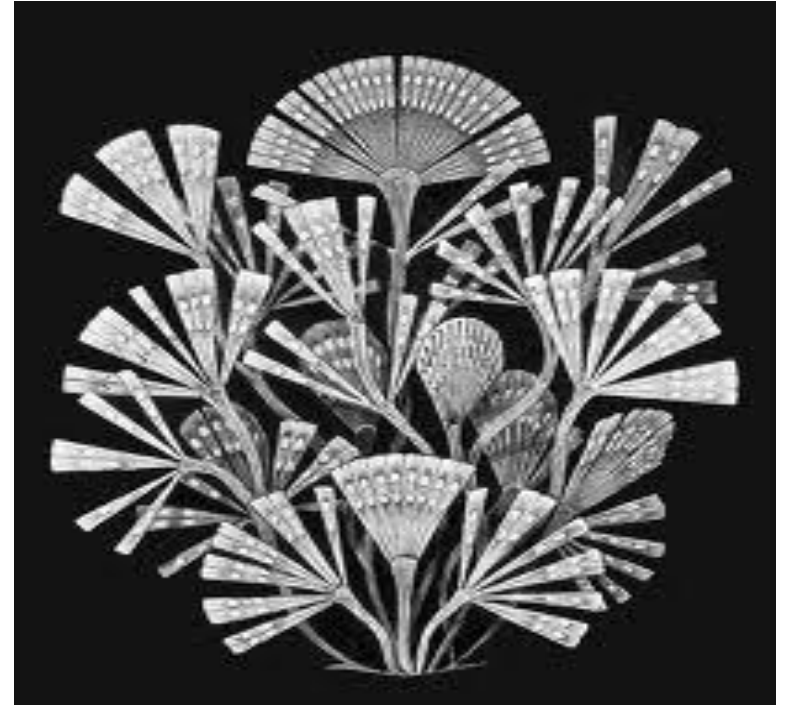

Genus : Licmophora
Species : flabellata

Order : Pennales

Family: Fragilariaceae



Genus : Fragilaria
Species : crotonensis

Family: Naviculeae

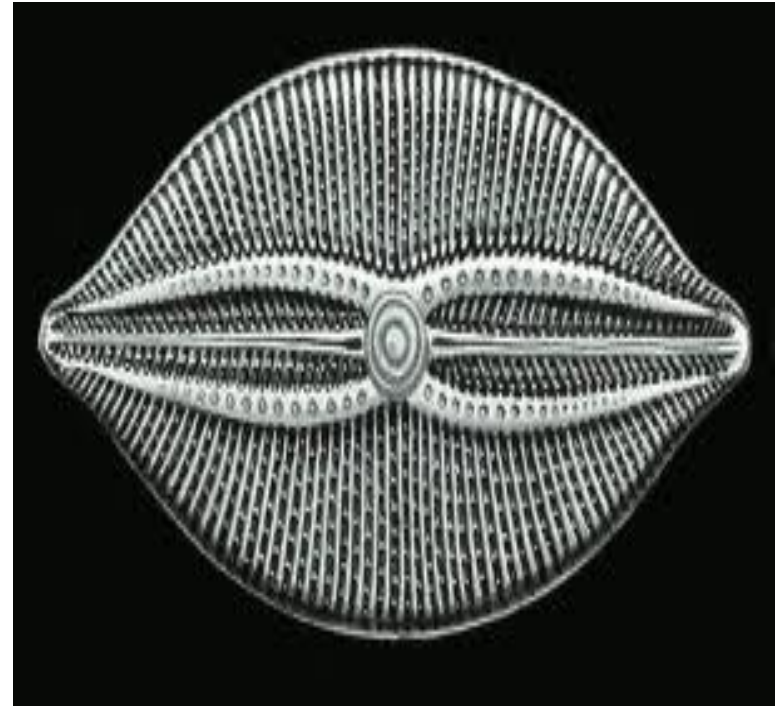

Genus : Navicula
Species : bullata

Order : Pennales

Family: Bacillarieae

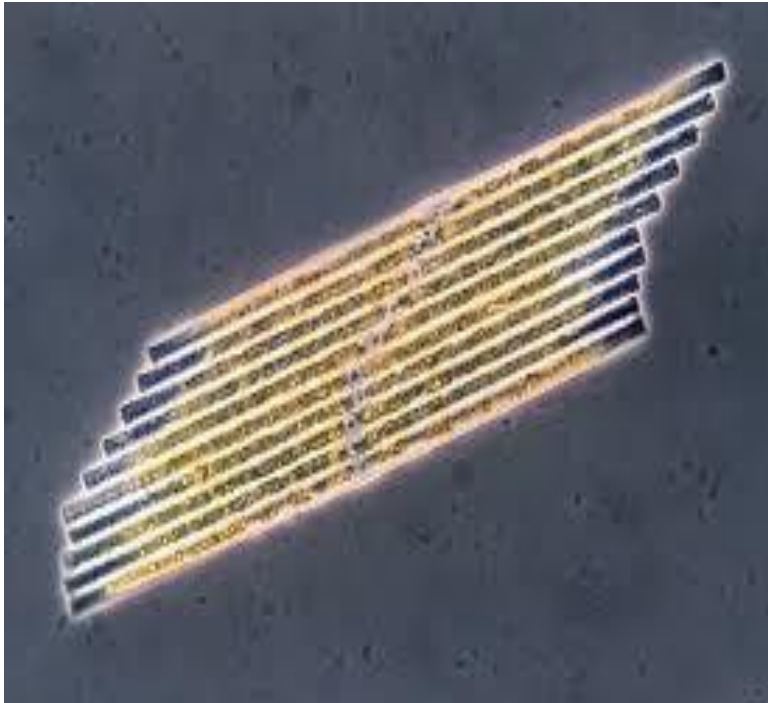

Genus : Bacillaria

Family: Surirelleae

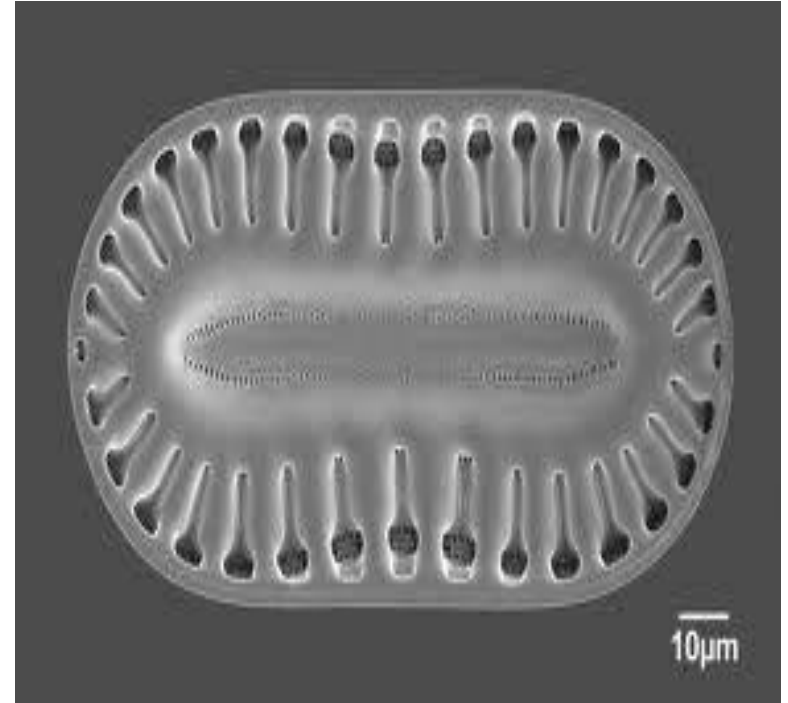

Genus : Surirella

Examination of Pollens

- ❑ Pollen grains are male reproductive units of plants produced in flowers.
- ❑ Pollens are easily transferred to clothing or any other object which touches the flowering plants.
- ❑ Presence of pollens on the clothing, earwax proves normal habitat of the person.
- ❑ Identification of Pollen grains helps in linking criminal with the crime.



Pollen analysis

- Pollen grains are abundant in almost all environments, are very durable and may persist on surfaces and in soils for many years .
- The pollen produced by flowering plants and conifers, along with the spores produced by ferns are microscopic and not visually obvious trace evidence at a crime scene.
- By examining the morphology of tiny pollen grains it is possible to identify the genus and often the species of the plant.
- Conducting analysis on multiple pollen grains allows for the vegetation composition of an area to be determined.

- The composition of pollen grains at a crime scene can then be compared with a sample taken from a suspect's clothes, shoes, hair or car.
- The time of year that the crime took place can also be derived as some pollen is only released during certain seasons.
- Pollen analysis works best when the crime scene is small such as the placement of an illegal snare or destruction of a bird of prey's nest.
- In both these cases pollen from the surrounding soil can be compared with pollen found on the suspect.

Examination of Poisonous Plant material

- Plants like Dhatura, Oleander, Croton, Nux Vomica, Abarus Pricatorius, Calotropis etc. are poisonous to humans
- Based on the microscopical identification of cell structure and other morphological characteristics residues of poisonous plants can be detected in the stomach wash of the deceased or victim

SEROLOGICAL ANALYSIS

Genetic Marker Systems used in Forensics

Antigenic

- A1A2B0
- Rh
- MN
- Ss -
- Kell
- Lewis
- Duffy
- Luthran
- Kidd
- P1
- Penny
- Sutlan
- Diego
- Xg
- Wright
- Vel
- Se

Enzyme

- PGM 1
- PGM 1 IEF
- EsD
- EsDIEF
- EAP
- ADA
- AK
- GLO1
- PG1
- PGP
- GPGD
- GCPD
- CA11
- POP-A
- GPT
- SoD
- Hb

Proteins

- HP
- Tf
- TfIEF
- Gc
- GCIEF
- Bf
- BFIEF
- CP
- AL
- PLG
- Pi
- C3

DNA

- RFLP-MLP
- RFLP-SLP
- Amp-FLP (DIS80)
- ABO Locus
- ACP Locus
- HLA Locus
- LDLR Locus
- GYPA Locus
- HBGG Locus
- D7S8 Locus
- Gc Locus
- STRs
- MVRs
- Species Identification
- Sex Determination

BASIS OF COMPARISION

- *PROTEINS Comparison - Blood Groups
 - Red Cell Enzymes
 - Serum Proteins
- *DNA Comparison -RFLP(MLP)
 - RFLP(SLP)
 - DOT Blot/RDOT Blot
 - STRs, Y-STRs, X-STRs
 - mt DNA

| System | Father | Mother | Child | Paternity |
|--------|--------|---------|--------|--------------|
| ABO | A 1 | A1 | O | Possible |
| Rh | Rh1 rh | Rh1 Rh1 | Rh1 rh | Possible |
| MN | M | M | M | Possible |
| Hp | 2-2 | 2-1 | 2-1 | Possible |
| PGM | 2-2 | 2-1 | 2-1 | Possible |
| EsD | 2-1 | 2-1 | 1-1 | Possible |
| GLO | 2-1 | 2-1 | 2-1 | Possible |
| ADA | 2-1 | 1-1 | 1-1 | Possible |
| EAP | BB | BB | BA | Not Possible |
| AK | 1-1 | 1-1 | 2-1 | Not Possible |

| System | Father | Mother | Child |
|--------|---------------------------------|---------------------------------|---------------------------------|
| ABO | BO | OO | OO |
| RhD | Dd | Dd | dd |
| Rh-sub | Cde/cde | Cde/cde | cde/cde |
| MN | MM | NN | MN |
| Ss | ss | ss | ss |
| Kell | kk | kk | kk |
| Duffy | Fy ^a Fy ^a | Fy ^a Fy ^a | Fy ^a Fy ^a |
| Luth. | Lu ^b Lu ^b | Lu ^b Lu ^b | Lu ^b Lu ^b |
| Penny | Kp ^b Kp ^b | Kp ^b Kp ^b | Kp ^b Kp ^b |

| | | | |
|------------|------|------|------|
| PGM 1 | 1-1 | 2-1 | 1-1 |
| PGM 1(IEF) | 1+1+ | 1-2+ | 1+1- |
| PGM 2 | 1-1 | 1-1 | 1-1 |
| EsD | 2-1 | 2-1 | 1-1 |
| EAP | BB | BB | BB |
| AK | 1-1 | 1-1 | 1-1 |
| ADA | 1-1 | 2-1 | 2-1 |

| | | | |
|----------|------|-----------|------|
| GLO | 2-2 | 2-2 | 2-2 |
| PGP | 1-1 | 1-1 | 1-1 |
| PGI | 1-1 | 1-1 | 1-1 |
| SOD | 1-1 | 1-1 | 1-1 |
| Hb | AA | AA | AA |
| Hp | 2-2 | 2-2 | 2-2 |
| Secretor | sese | SeSe/Sese | sese |

Antibody Profiling

- Everyone has a unique antibody profile.
- At birth, antibody are identical to those mother
- Then profiles gradually change until about the age of 2, then a stable pattern is formed.
- Then antibody profile never changes.
- Identical twins have their own unique individual antibody profile.

- As compared to the proteins which form the basis of conventional testing (serological and electrophoretic), DNA is more stable in evidence materials exposed to various environmental insults and highly polymorphic in individuals

Thus, advances in the field of molecular biology has augmented the scope of conventional forensic genetic testing.

DNA ANALYSIS

DNA....Discoveries

- ❑ 1869: Johann Friedric Miescher separated nuclei from human WBC for searching protein in the nuclei
- ❑ Instead of protein he found a substance which was chemically different from the substances known at that time. He named it Nuclein and later on Nucleic Acid
- ❑ 1920s: Phoebus A.T. Levene differentiated Nucleic Acid into RNA and DNA
- ❑ 1944: Oswald Avery – DNA as vehicle of transference of heritable traits
- ❑ 1953: James Watson and Francis Crick – double helix structure of DNA molecule
- ❑ 1980: David Botstein and coworkers found small variations through RFLP analysis of DNA
- ❑ 1984: Alec Jeffreys discovered a unique application of RFLP technology for personal identification termed as DNA fingerprinting
- ❑ 1986: Kary Mullis invented PCR

Who Invented it?

- The process of DNA fingerprinting was invented by Alec Jeffreys at the University of Leicester in 1985.
- He was knighted in 1994.



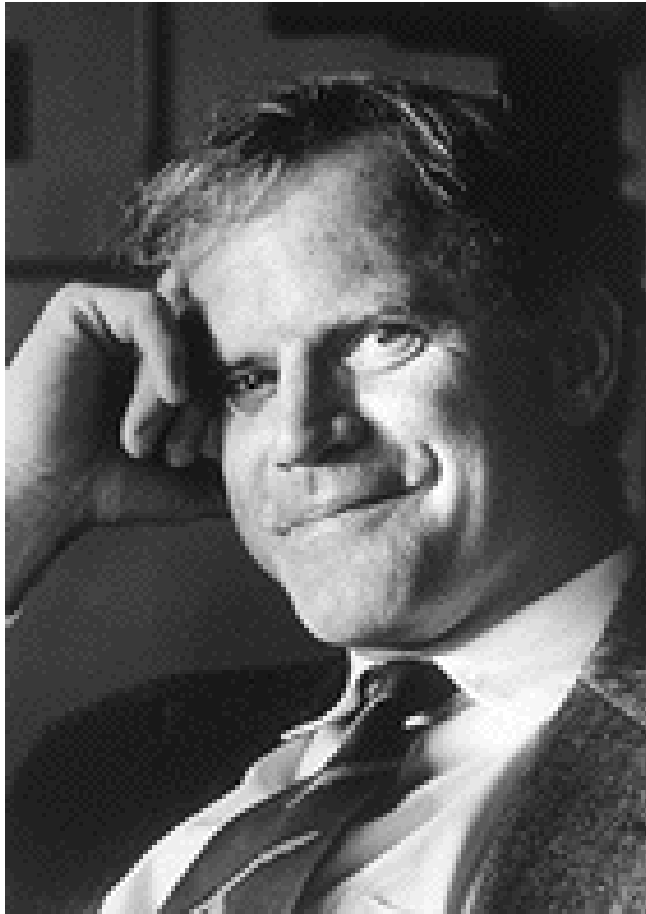

Kary Mullis

**Devised Poymerase
Chain Reaction (PCR)**

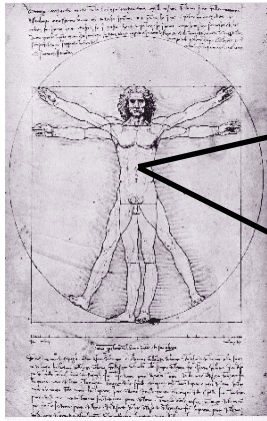

Cell



Nucleus

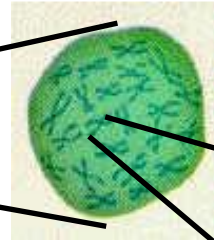

Chromosome

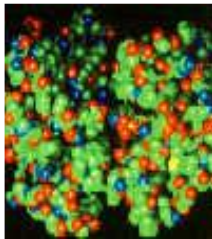
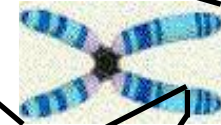

Protein

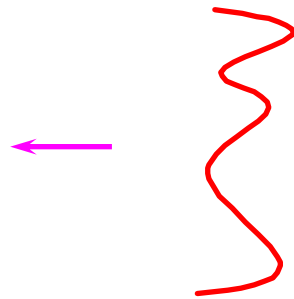

Gene (mRNA),
single strand

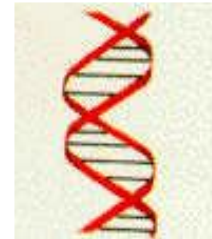

Gene (DNA)



DNA in the Cell

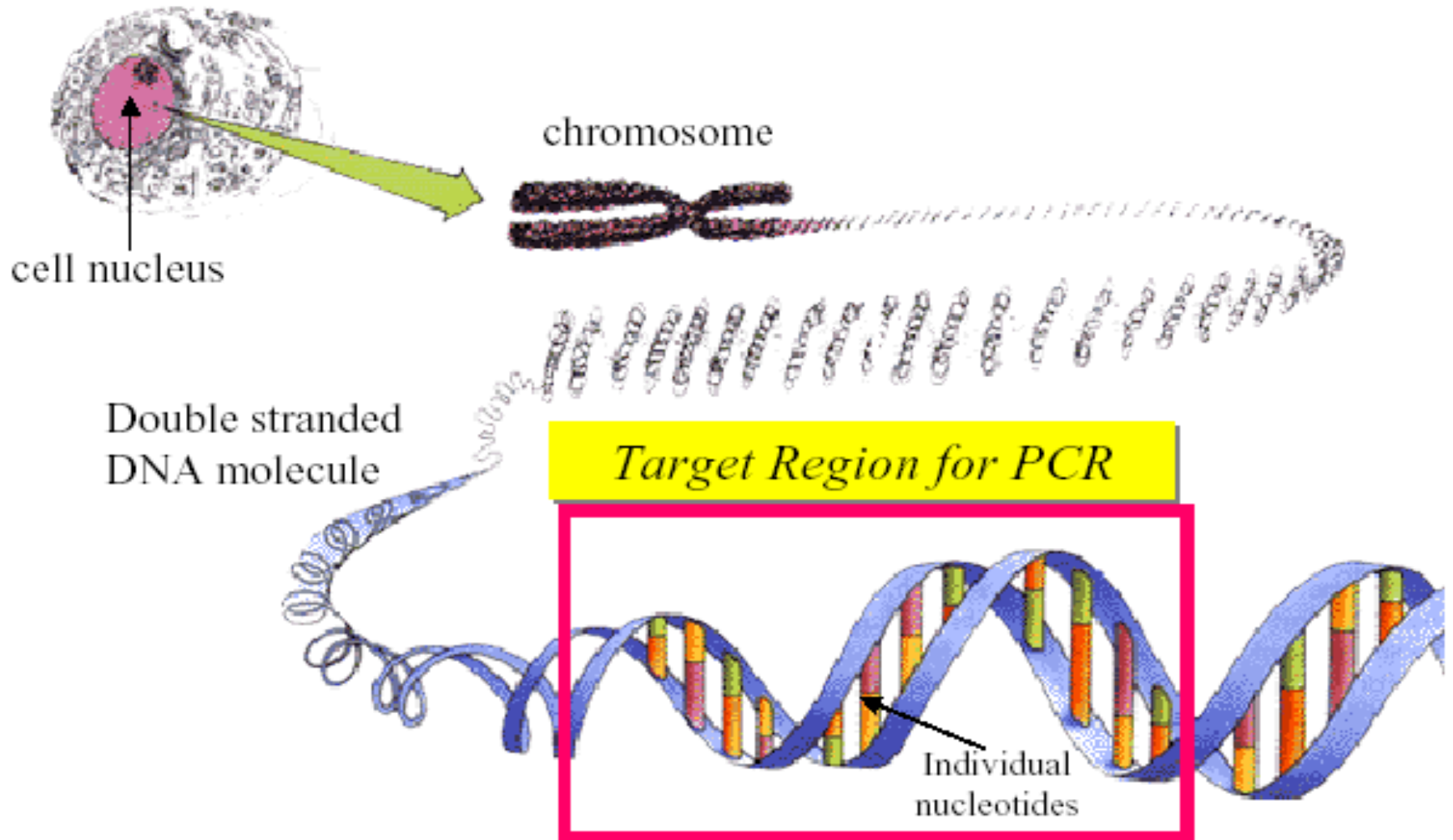

DNA structure

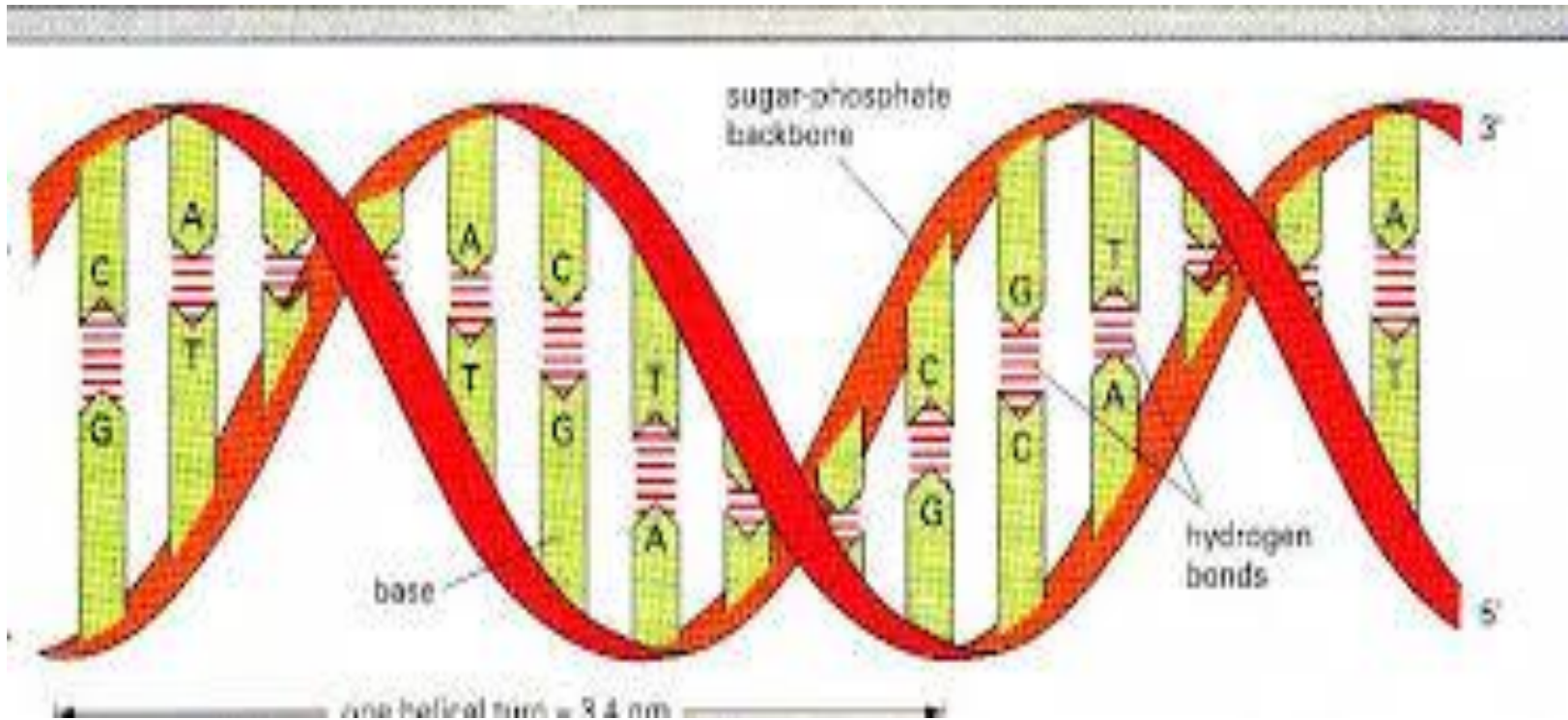

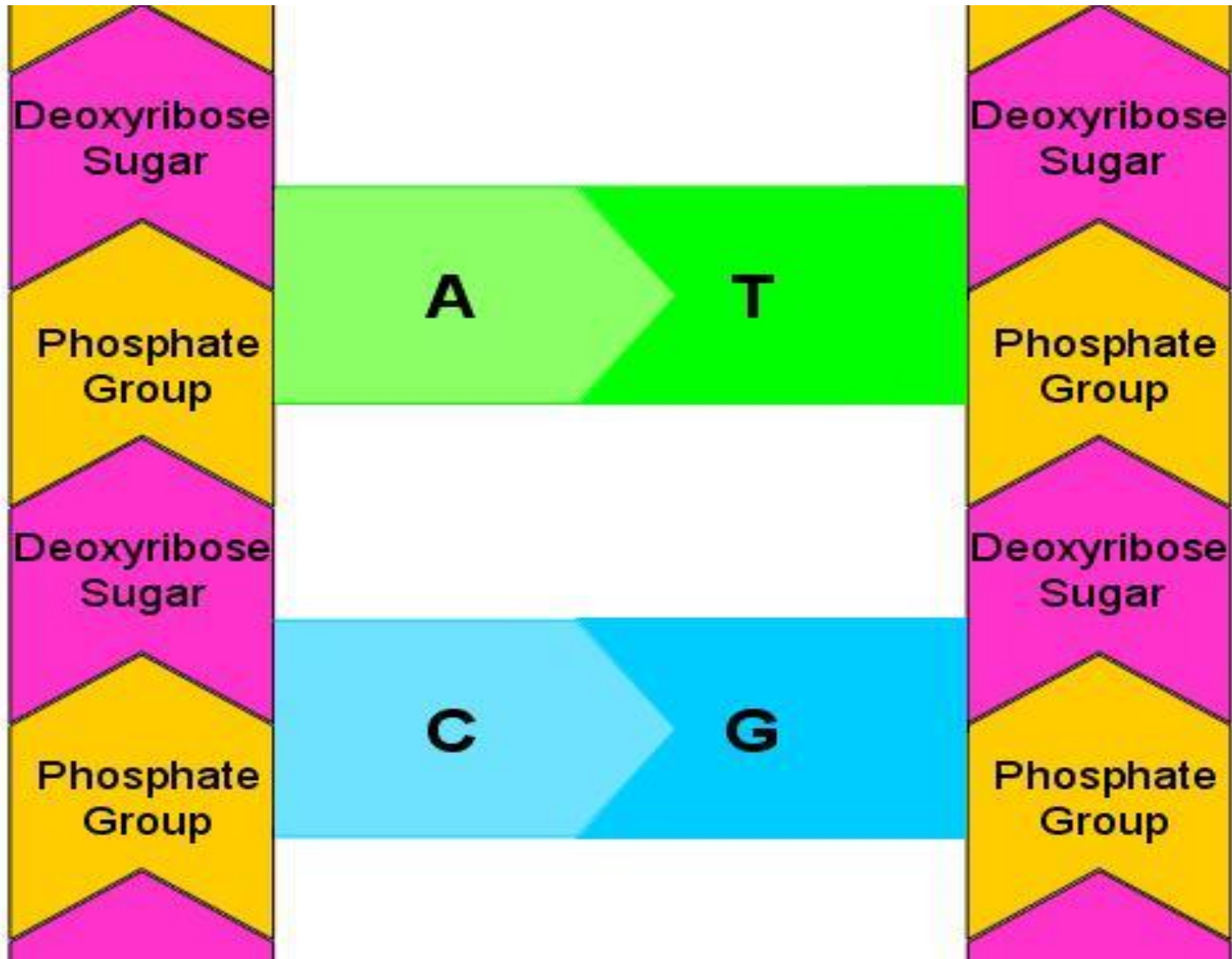

DNA STRUCTURE 2

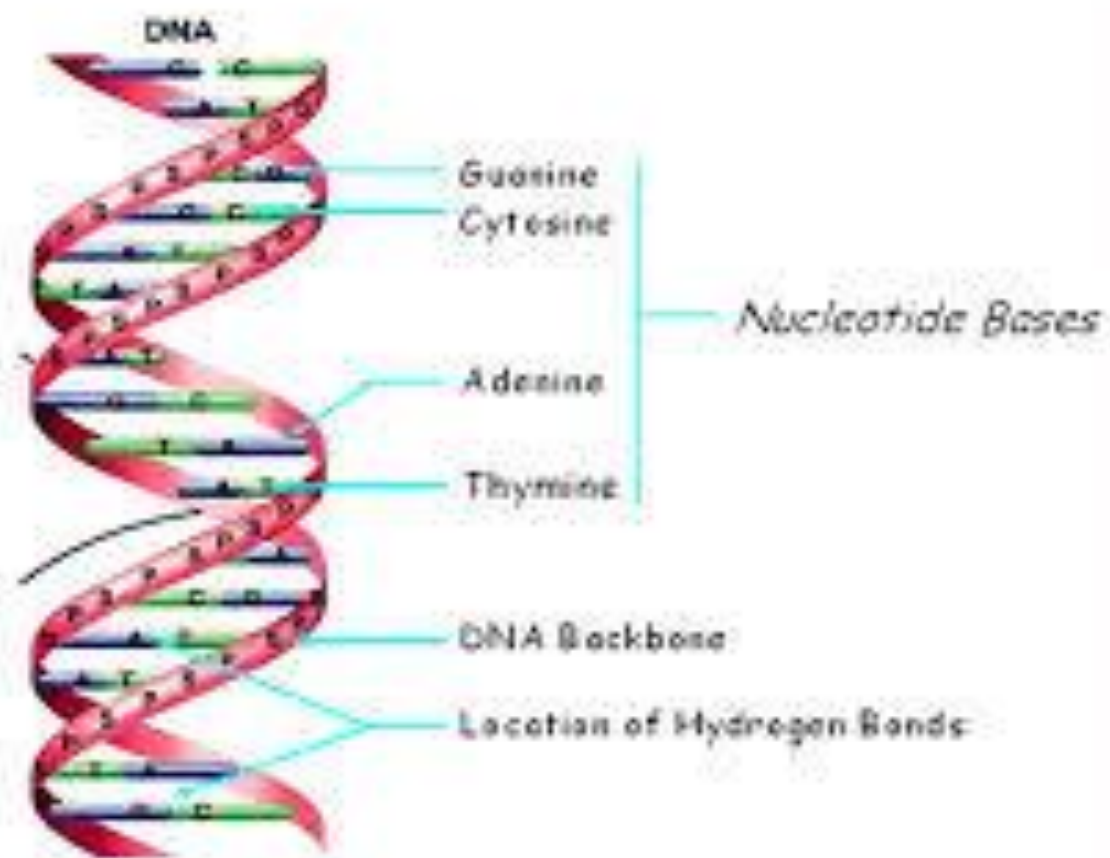

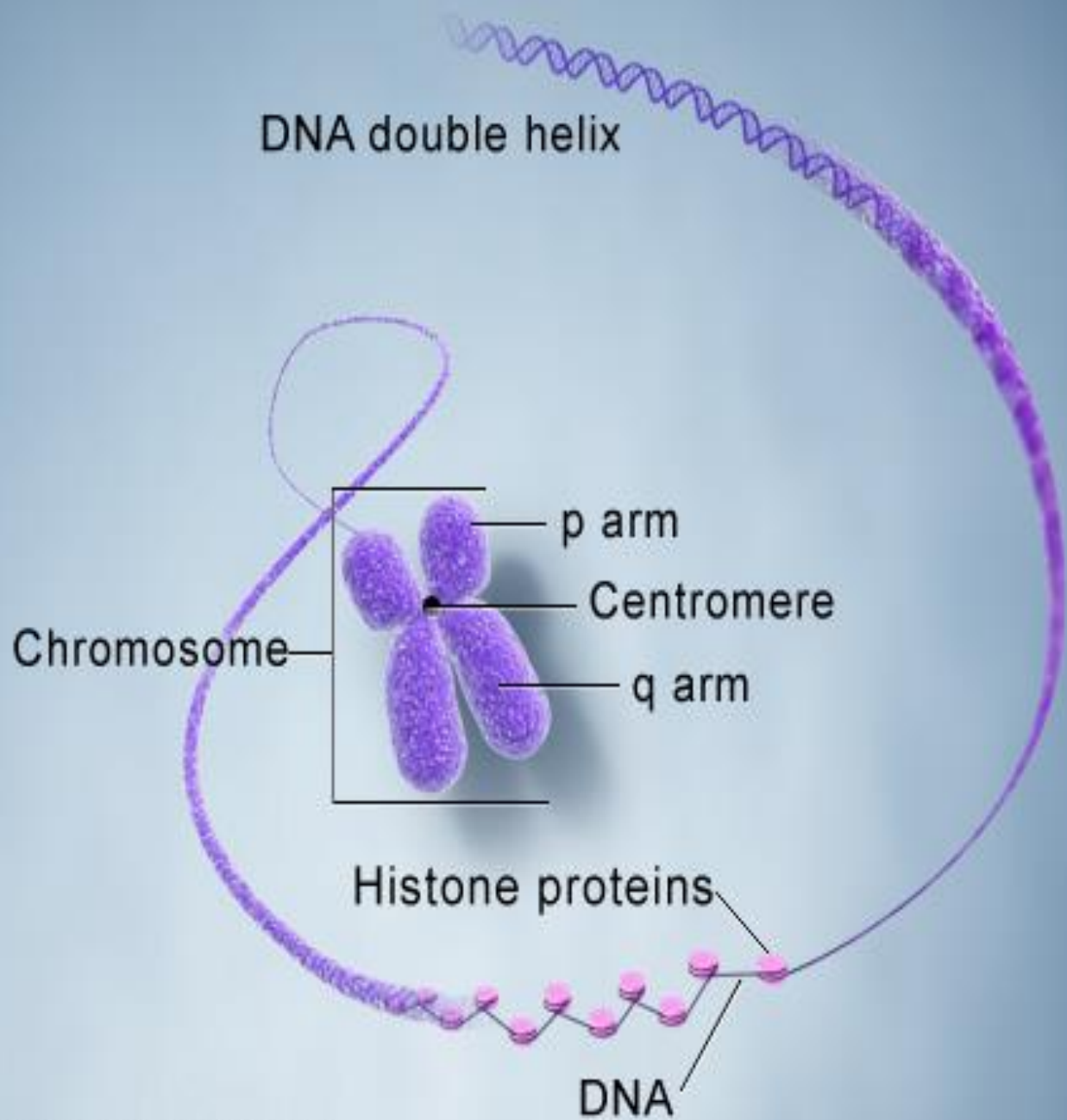

Chromosomes and DNA

- Our genes are on our chromosomes
- Chromosomes are made up of a chemical called DNA

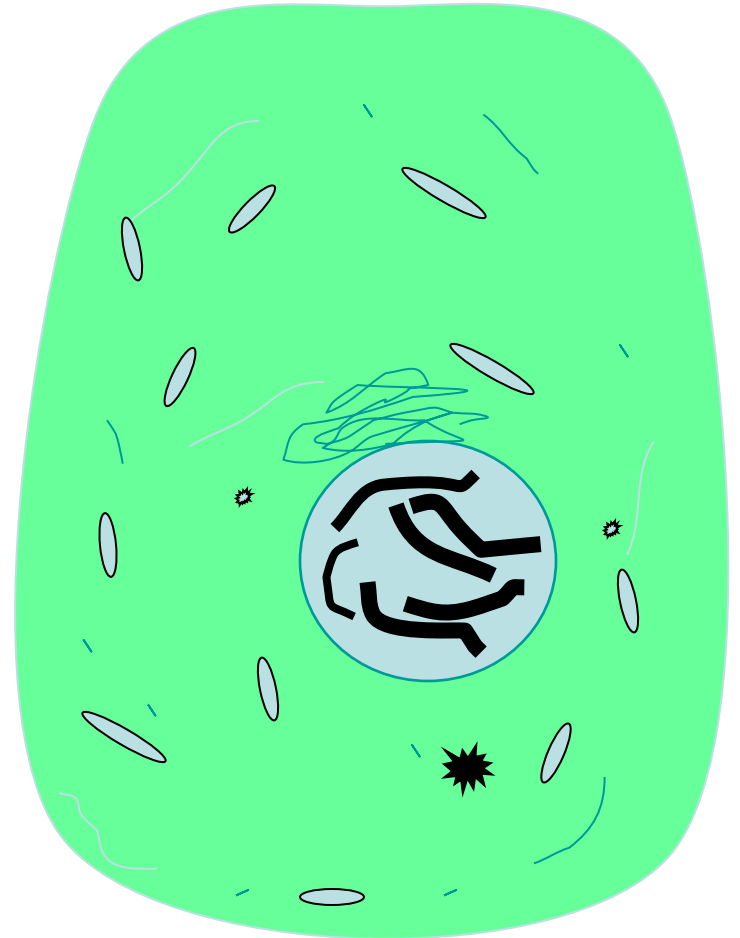

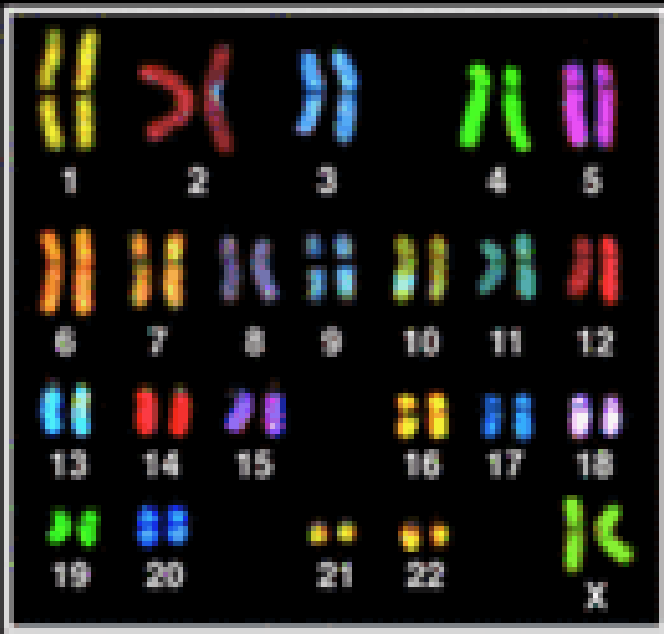
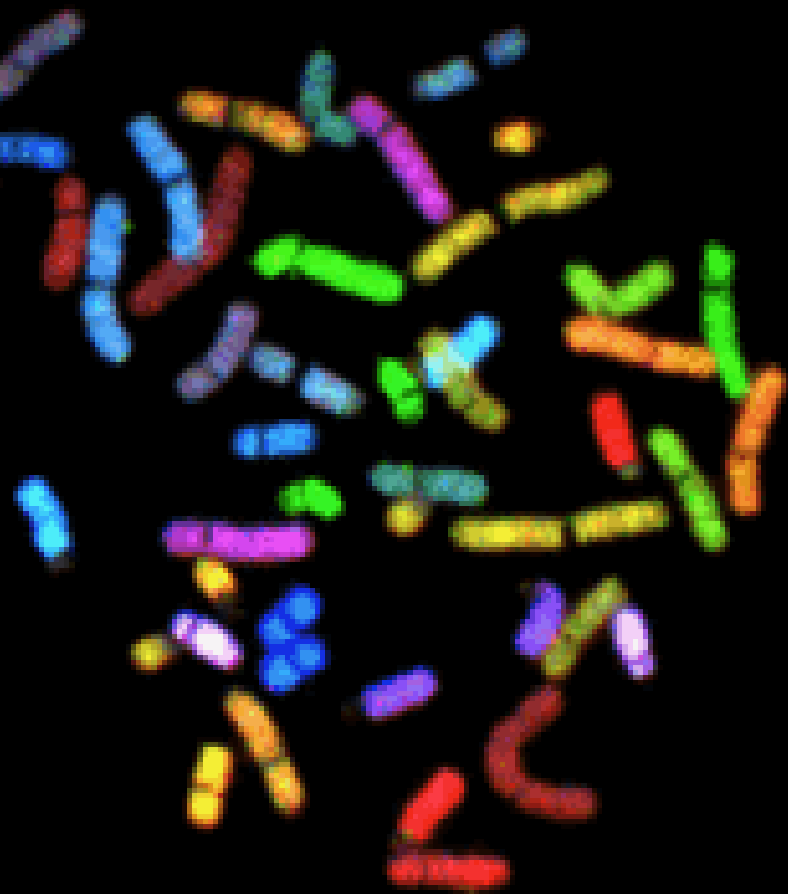
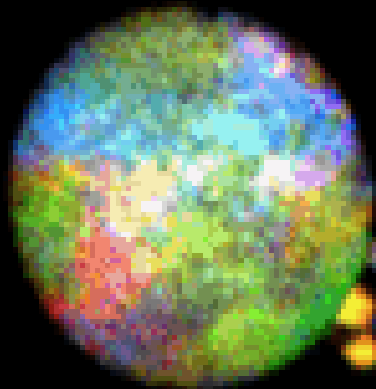

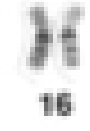
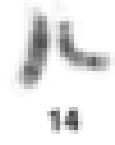
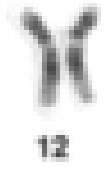
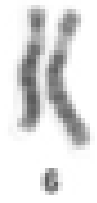
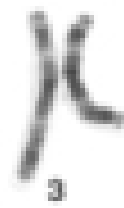

Human Genome

23 Pairs of Chromosomes + mtDNA

Located in cell nucleus

Autosomes *2 copies per cell*

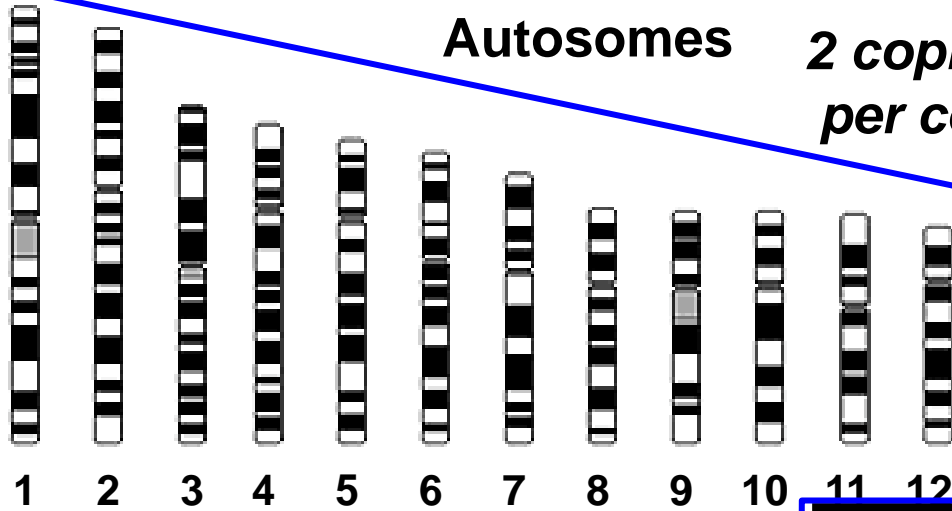

1 2 3 4 5 6 7 8 9 10 11 12

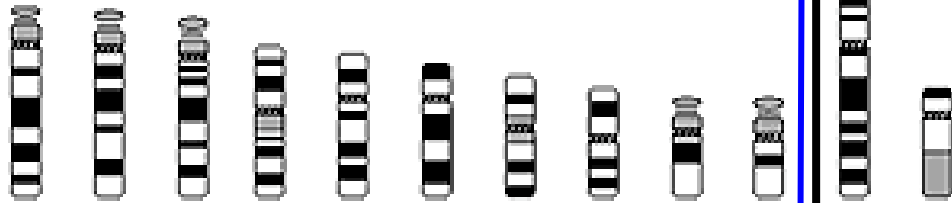

13 14 15 16 17 18 19 20 21 22 X Y

Nuclear DNA
3.2 billion bp

Sex-chromosomes

Located in mitochondria
(multiple copies in cell cytoplasm)

mtDNA
16,569 bp



Mitochondrial DNA

100s of copies per cell

One Strand of DNA

- The backbone of the molecule is alternating **phosphate** and **deoxyribose**, a sugar, parts.
- The teeth are nitrogenous **bases**.

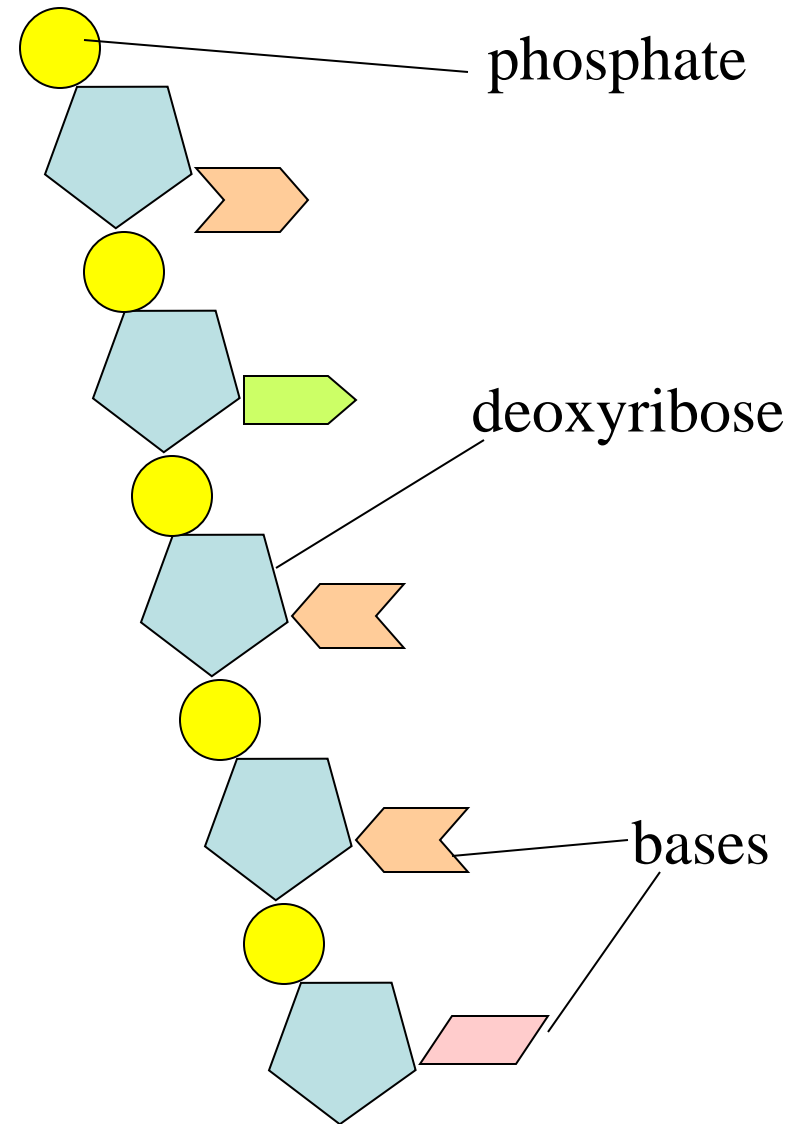

One Strand of DNA

- One strand of DNA is a polymer of nucleotides
- One strand of DNA has many millions of nucleotides

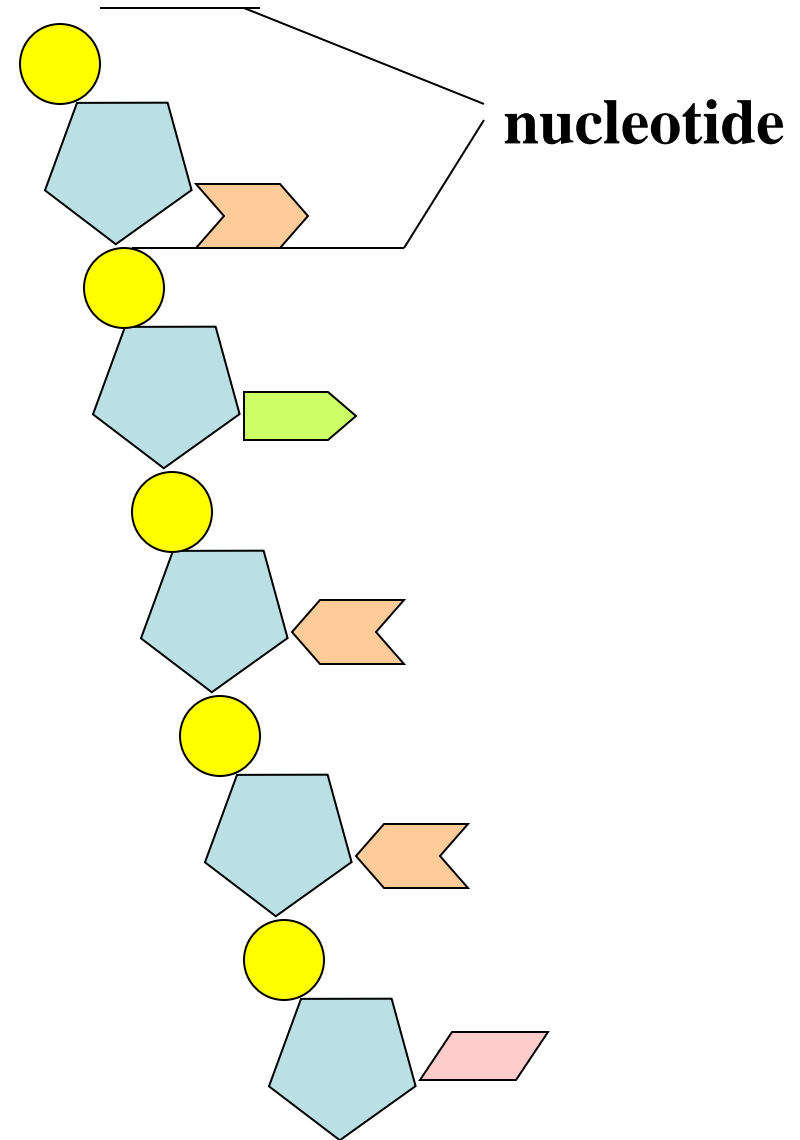

Two Stranded DNA

- Remember, DNA has two strands that fit together something like a zipper.
- The teeth are the nitrogenous bases .

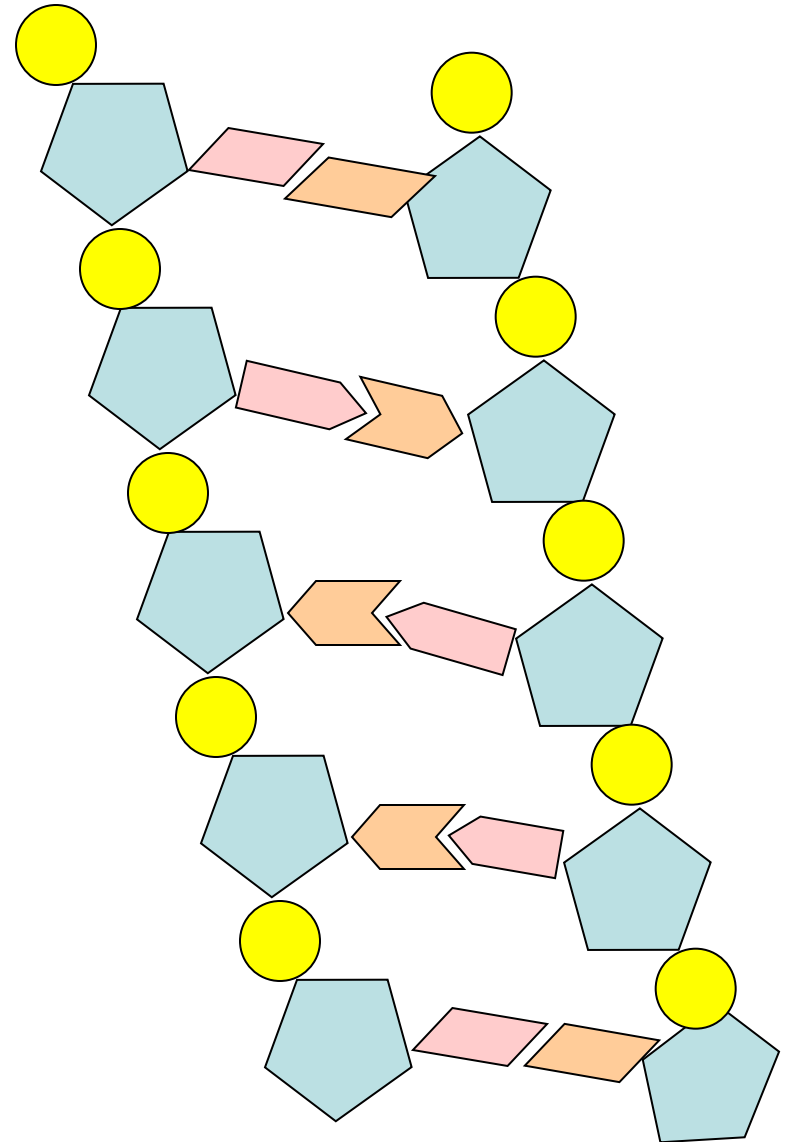

The Shape of the Molecule

- DNA is a very long polymer.
- The basic shape is like a twisted ladder or zipper.
- This is called a double helix.

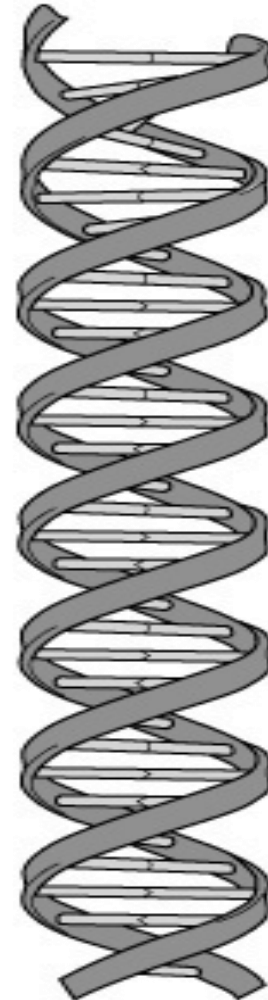

Four nitrogenous bases

DNA has four different bases:

- Cytosine **C**
- Thymine **T**
- Adenine **A**
- Guanine **G**

Important:

- Adenine and Thymine always join together

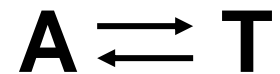

- Cytosine and Guanine always join together

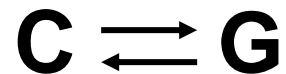

DNA Strand is made up of letters :

e.g TAGCTCGCCTAAAGCTCA

These letters make words like :

ATG CTC GCC TAA AGC TCA

These words make sentences like :

(ATG CTC GCC TAA)(AGC TCA)

Gene

Gene

DNA Sequence

- About 6.4 billion base pairs are arranged along the 46 chromosomes in a unique sequence in our each cell
- 2 lac pages of telephone directory are required to type the sequence of bases (DNA sequence) along the entire length of DNA
- Reading the DNA sequence nonstop at the rate of 10 bases/sec (ATCGATCGAT/sec) or 600 bases/min. or 3600 bases/hr or 8,64000 bases/day or 3,53,60,000 bases/year, it would take 9.5 years to complete the job

DNA by the numbers

- Each cell has about 2 m of DNA .
- The average human has 75 trillion cells.
- The average human has enough DNA to go from the earth to the sun more than 400 times.
- DNA has a diameter of only 0.000000002 m.



The earth is 150 billion m or 93 million miles from the sun.

Human body DNA is approx.
125 billion miles long , which
can go between earth and
moon 8000 times.

Gene: DNA

- ❑ Human Body contains ~ 220 types of specialized cells.
- ❑ Only Nucleated Cells contain chromosomes, made up of DNA.
- ❑ Sex cells act as vehicle for bringing $\frac{1}{2}$ the genetic information from each parent to the offspring
- ❑ DNA programmes the working of cell.
- ❑ 99.9% of human DNA is same in every individual, only 0.1% of our DNA is unique.

Overview of the DNA Testing Process

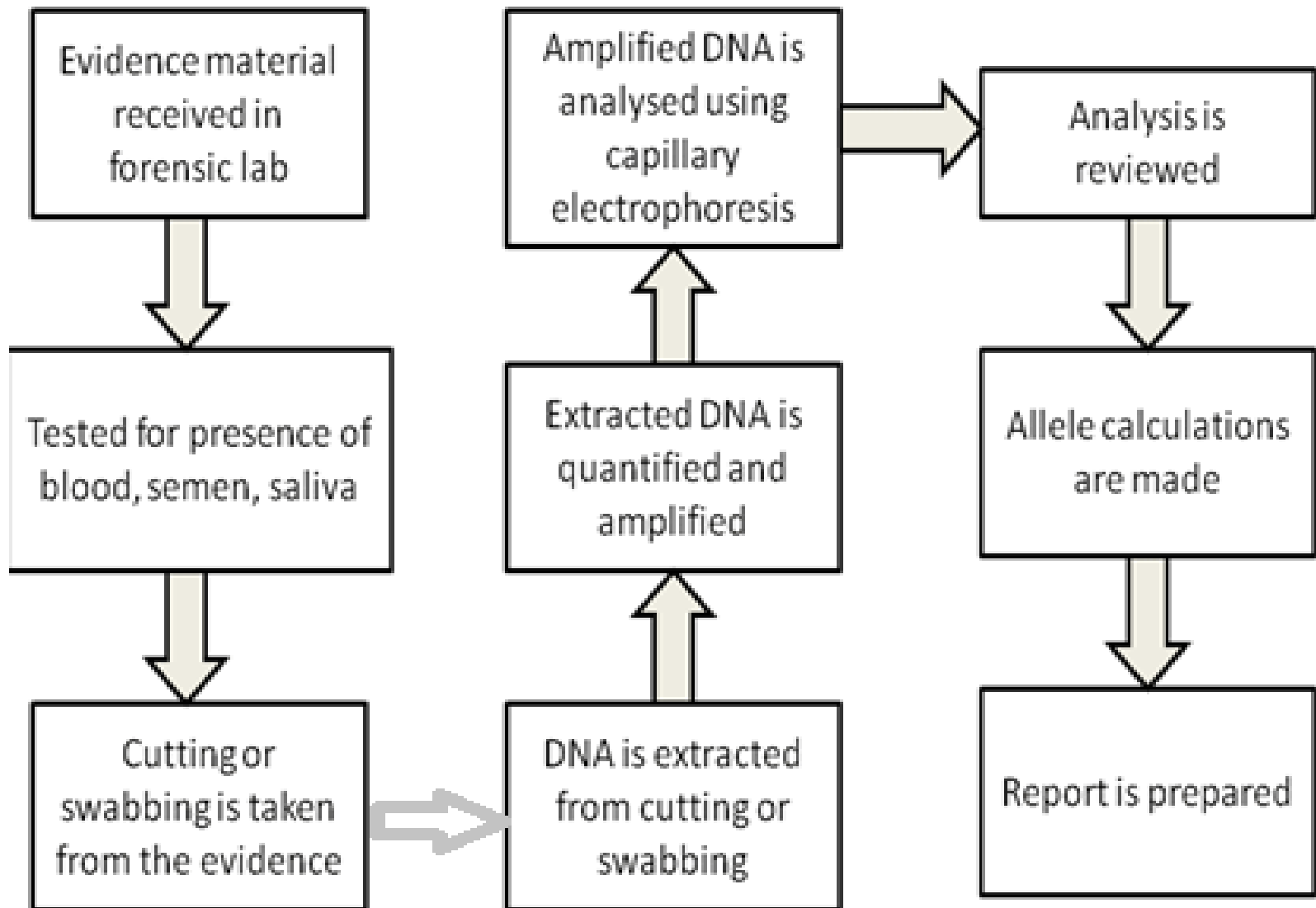

Steps in Sample Processing

Sample Obtained from
Crime Scene or Paternity
Investigation

Biology

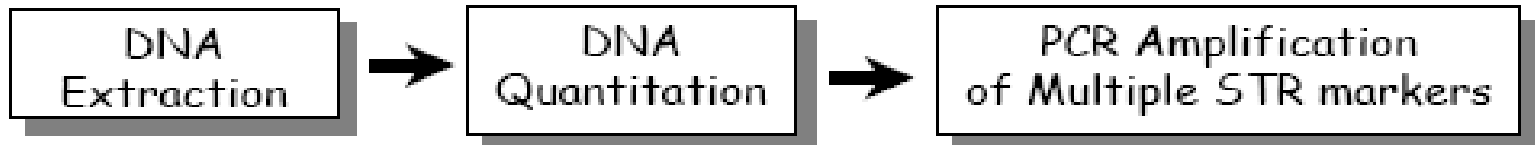

Technology

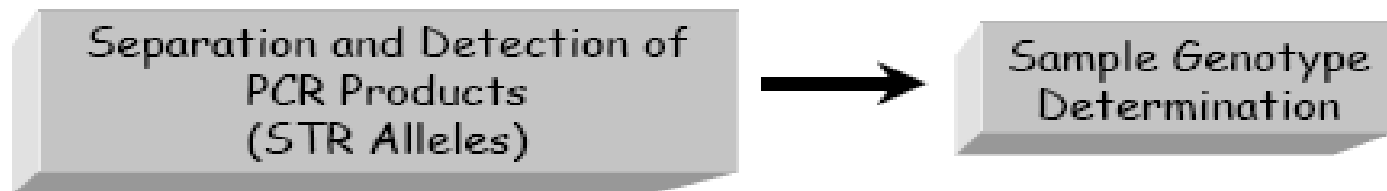

Genetics

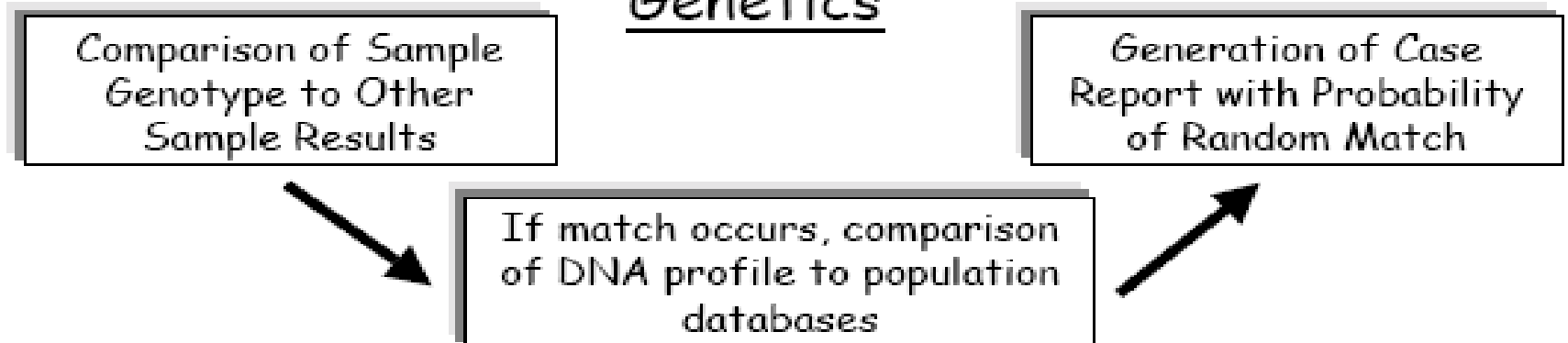

Biological materials used for DNA profiling



Almost all body fluids and organs containing cells with nucleus (blood, semen, saliva from bite marks/cigarette butts/postage stamps/mask, hair roots, bones, dandruff, mucus, ear wax, nasal secretion)

DNA can be extracted from :

- Blood /Semen/ Saliva and their stains
- Organs and tissues
- Bones, teeth
- Hair
- Urine and faecal matter
- Sweat, tears, ear wax, finger print
- Skin and muscle tissues
- Dandruff
- Samples of plant origin
- Microorganisms

- DNA samples have been obtained from **vaginal cells transferred to the outside of a condom** during sexual intercourse.
- Cells in the outside layer of skin contain few or no nuclei
- Nucleated cells may be transferred from the skin surface through sweat and sebaceous oil secretions.
- Hence, DNA deposited on any surface through casual contact can be recovered and typed using sensitive PCR based technique

- Urine (when concentrated) and faecal matter also contain nucleated cells
- Hair shaft and nail clipping contain mt. DNA
- Concentration of sperm and **semen** and epithelial cells in **saliva** is higher than that of blood cells in blood, hence less amount of semen/saliva is required as compared to blood. Thus quantity of all the samples depends upon density of the nucleated cell per sample.
- DNA can be isolated from liver, spleen, gonad, kidney and skin
- **Liver and brain decompose first, prostate gland and uterus gland are last to decompose**

- Wild life samples
 - Brain, heart, red muscles, hide with attached reddish tissues are best.
- Microbial samples
 - Identification of pathogens (Anthrax) in terrorist cases

DNA Content of tissues

| | |
|----------------|---------------|
| 1 Sperm | = 3 pg |
| 1 Blood cell | = 6 pg |
| 1 Plucked hair | = 300 ng |
| 1 Shed hair | = 10 ng |
| 1 Drop blood | = 1500 ng |
| 1 mg liver | = 15 micro gm |
| 1 mg muscle | = 3 micro gm |

Application of DNA in Forensics

- Criminal cases
 - Blood, Semen, saliva, bone, hair, and other body tissues encountered in physical and sexual assaults, murder, accident, concealment of birth
 - Identification/restoration of kidnapped/exchanged babies
 - Identification of babies born out of wedlock or sexual assault
 - Identification of mutilated bodies in mass disaster cases, when conventional method of identification fail

- Identification of plant materials and microbes
- Identification of species of biological evidence material in poaching cases.
- In cases of sudden death/unexplained deaths in athletes and in cases of sudden infant death syndrome, sequence analysis of human cardiac-beta-myosin heavy chain gene using mRNA extracted from PM tissues to verify genetic defect
- In linking cases e.g different rape cases –serial rapist
- Civil Cases
 - Determination of paternity/maternity
 - Inheritance cases
 - Immigration cases

- Medical Applications
 - Post transplant cell population identification
 - For monitoring engraftment.
 - Twin zygosity determination
 - Tumor analysis
 - Identification of micro organism
 - Tissue culture cell line identification

Soil microbial DNA profile

Represent the site of collection-
proves a link between suspects
and crime scene.

- Traditional Chinese medicine stated to contain Tiger-bone were found to contain cow and pig DNA.

- DNA profiling of azoospermic semen-epithelial /white cells –Y STR

- Micro organisms as foodstuff contamination , in medical negligence cases involving infections- HIV transmission.
- Natural disease out break.
Anthrax (spores of bacillus anthracis)- in act of bioterrorism.

- Success has been reported in the recovery of DNA from burned remains extracted from fire victims exhibiting extreme charring.

- In China - Bus with 35 sleeper berths caught fire at 4 am which was put off at about 6 am .
- Bodies inside the vehicle were carbonized, and could only be identified through DNA



- DNA typed successfully for STR from dental pulp after teeth had been exposed to temp. up to 300 degree C.
- And for Mt DNA up to 500 C

- Long bone fragments burnt at 800 C and thigh skeletal muscles at 900 C. have been typed for STRs

Identification of Unidentified Bodies

- If laboratory succeeds in extracting DNA (from the evidence material) and developing the profile.

Blood samples of suspected sources - parents/siblings/spouse of the unknown are obtained for comparison.

STR Typing

- 3-7 bp sequences, tandemly repeated, found throughout the human genome.
- More than 30 STR loci have been validated for forensic use.
- Several STR Loci can be co-amplified
- Amplified fragments are separated on PAGE and stained to visualize the bands
- STRs are also analyzed using automated DNA sequencer

➤ STR-based forensic testing has achieved worldwide public and professional acceptance as a reliable means of individual identification and has made a major impact on criminal justice system.

Why STRs are Preferred Genetic Markers

- Rapid processing is attainable
- Abundant throughout the genome
- Highly variable within various populations
- Small size range allows multiplex development
- Discrete alleles allow digital record of data
- Allelic ladders simplify interpretation
- PCR allows use of small amounts of DNA material
- Small product size compatible with degraded DNA

Short Tandem Repeats (STRs)

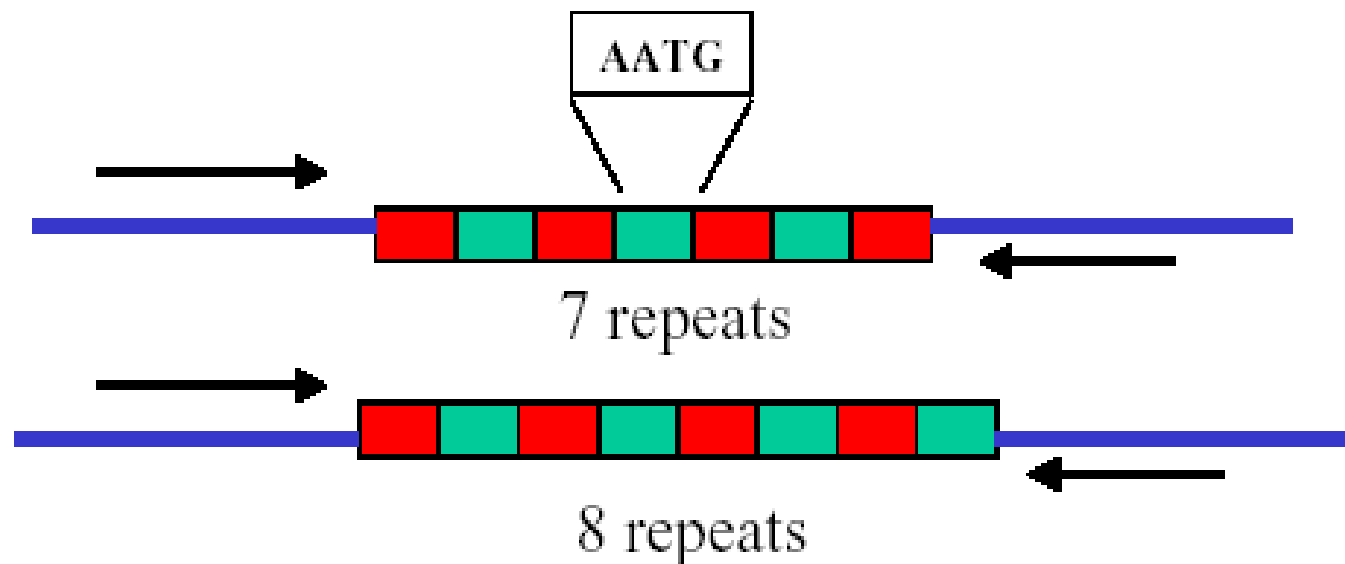

the repeat region is variable between samples while the flanking regions where PCR primers bind are constant

Homozygote = both alleles are the same length

Heterozygote = alleles differ and can be resolved from one another

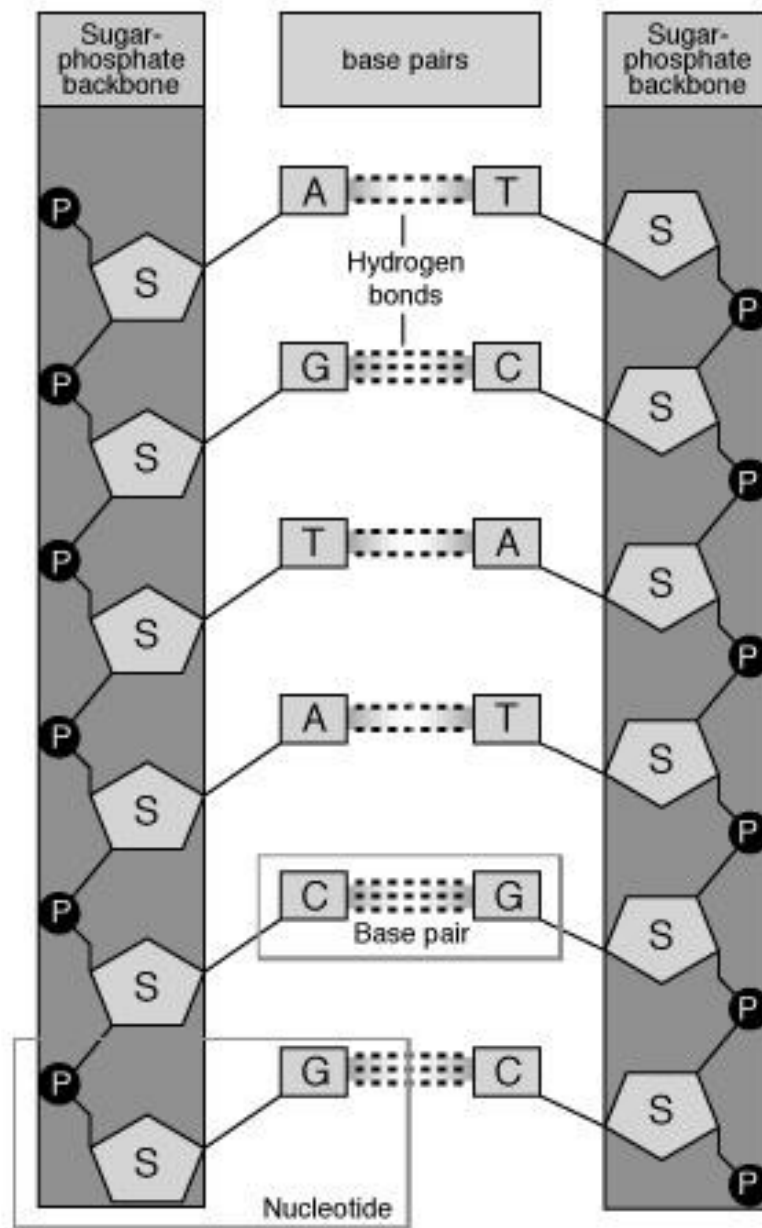

13 CODIS Core STR Loci with Chromosomal Positions

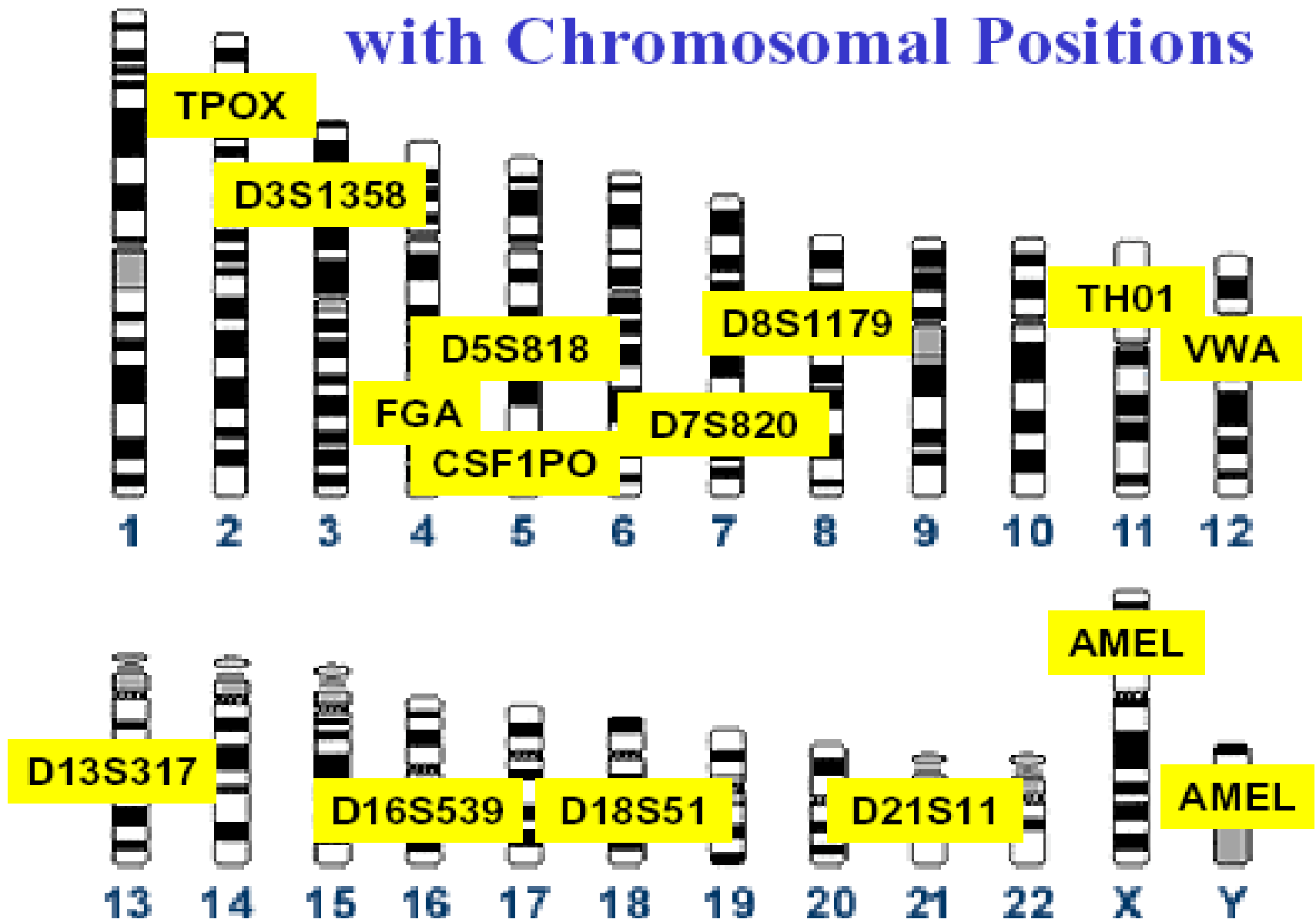

Chromosomal Positions

15 autosomal + Amelogenin STR Loci

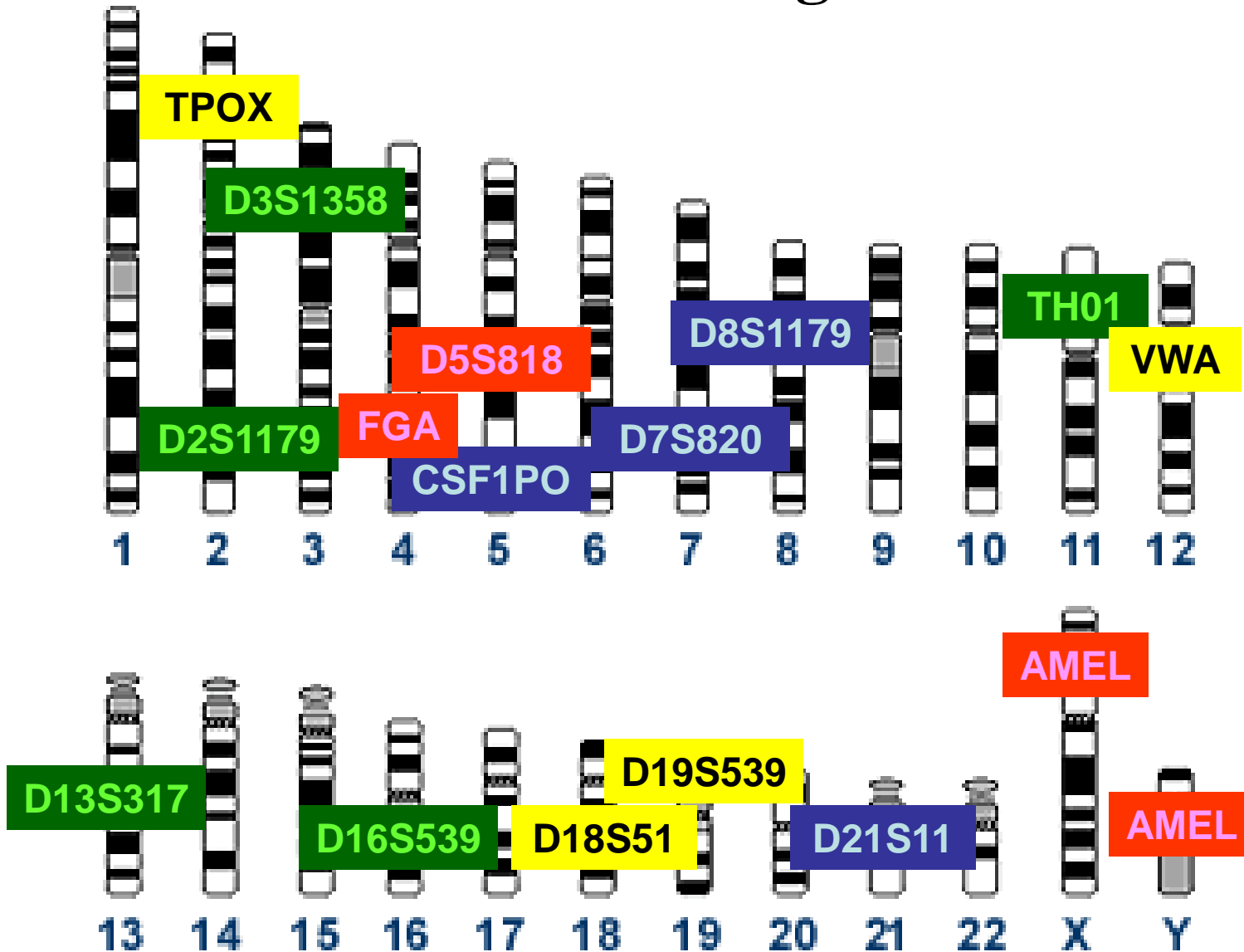

Thermal Cycling Temperatures

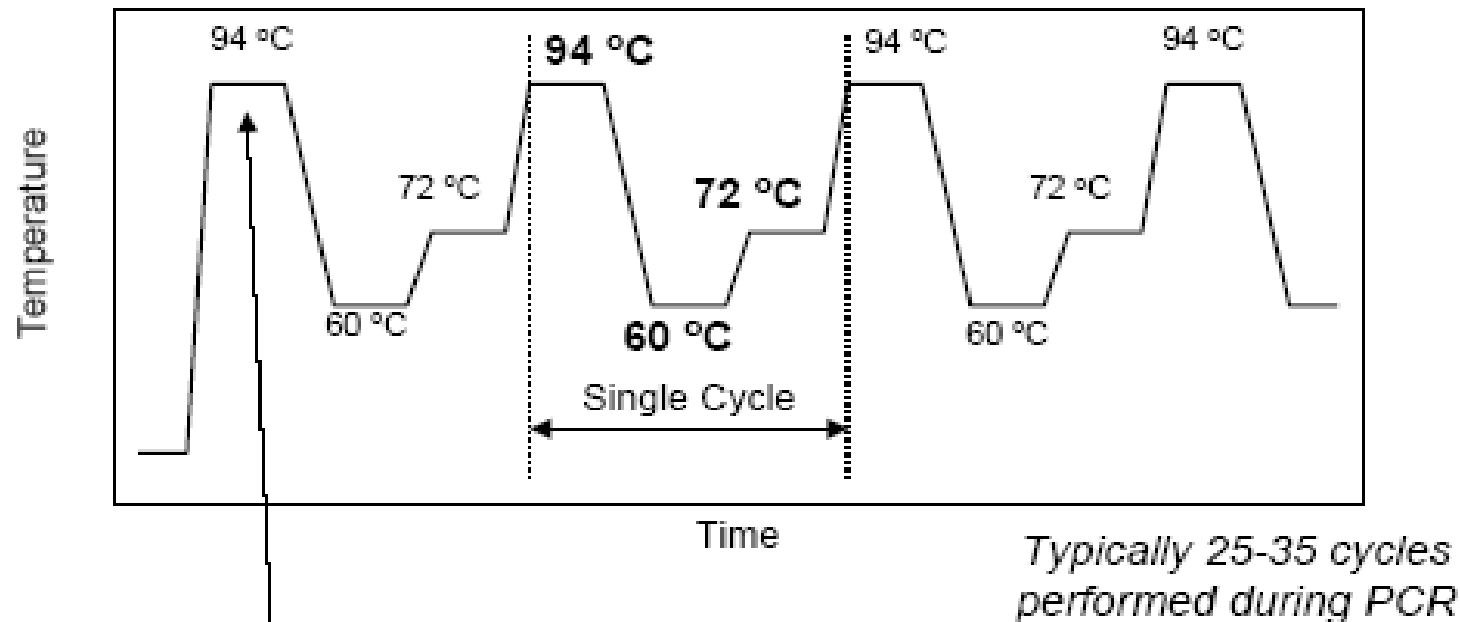

The denaturation time in the first cycle is lengthened to ~10 minutes when using AmpliTaq Gold to perform a "hot-start" PCR

X. Representative STR Data

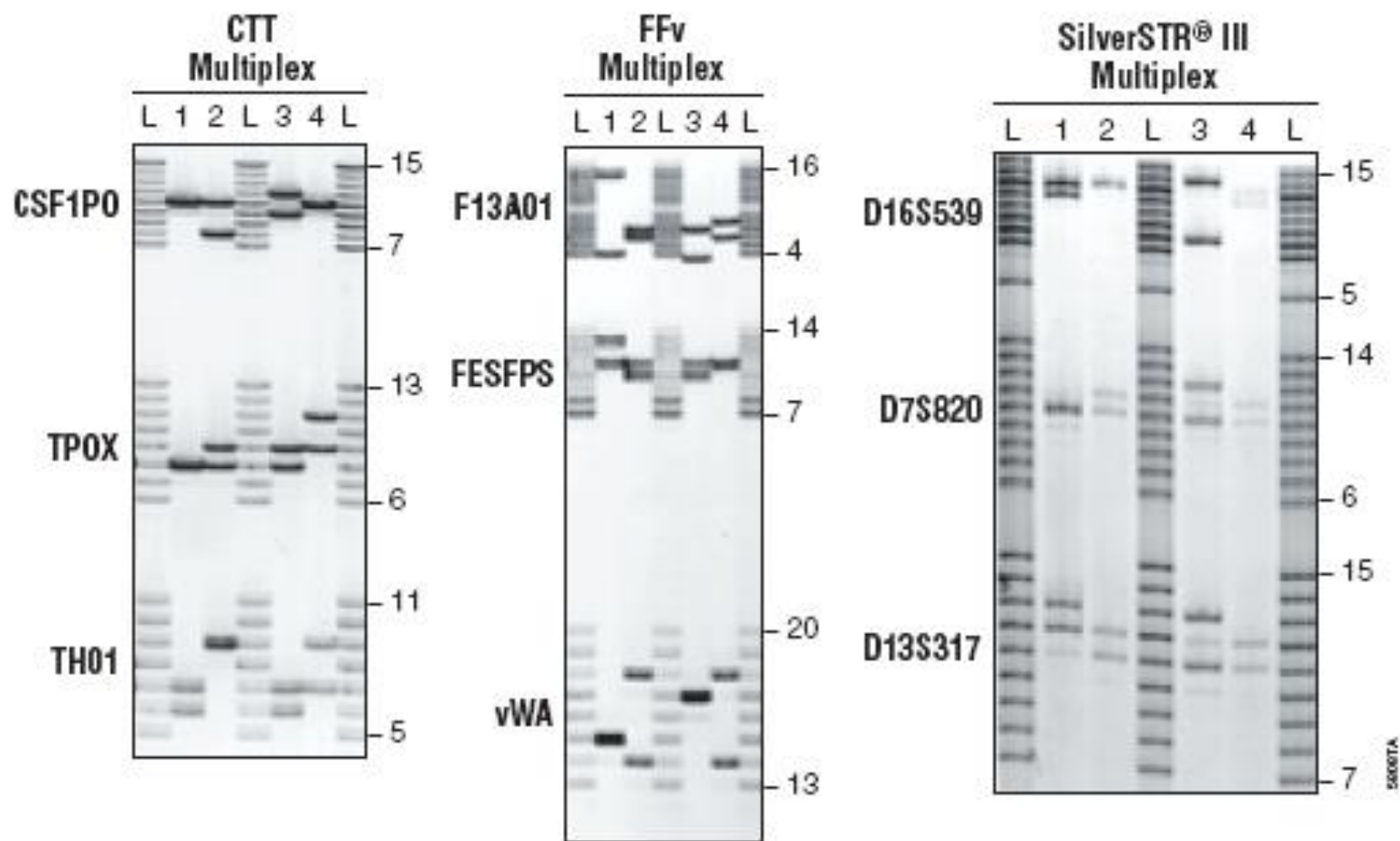

4% Denaturing Gel

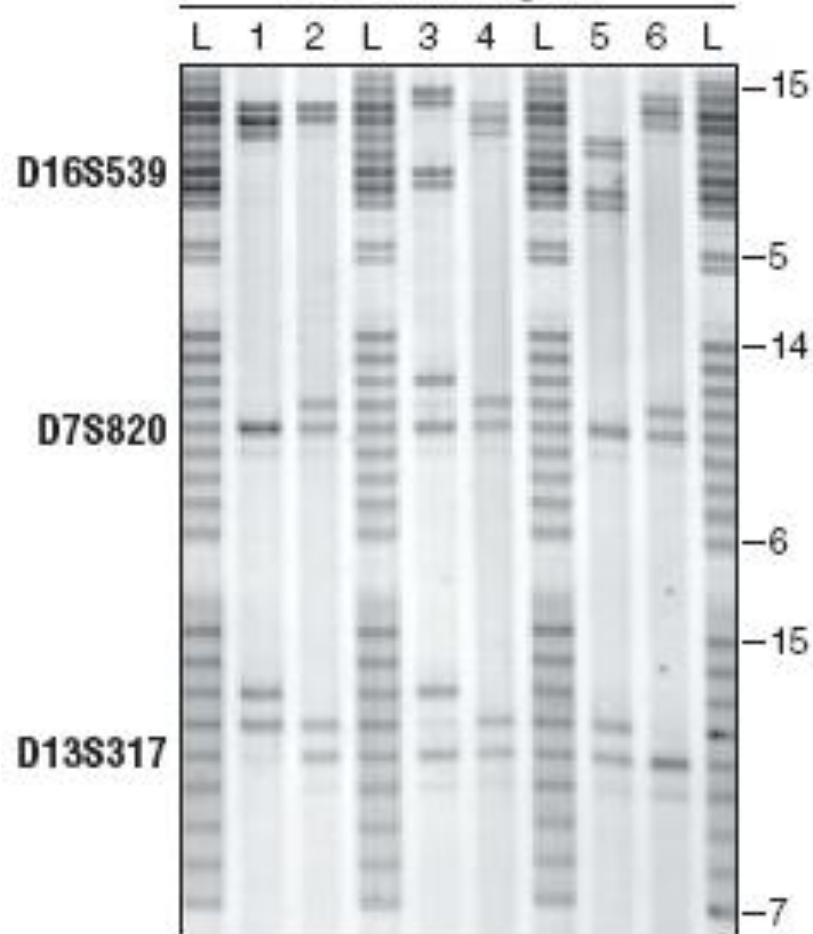

6% Denaturing Gel

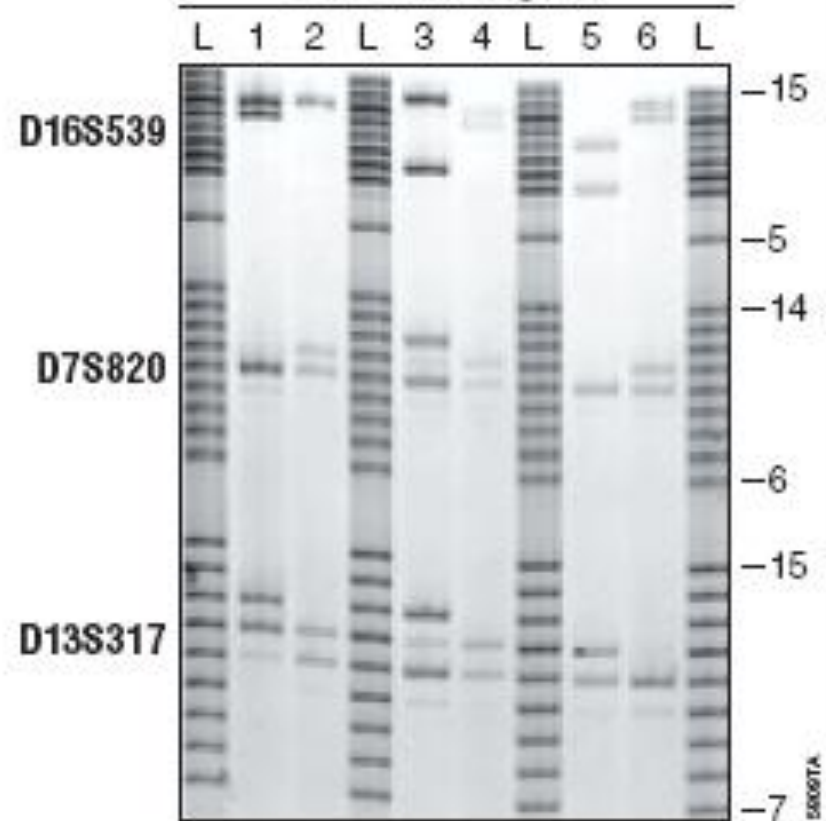

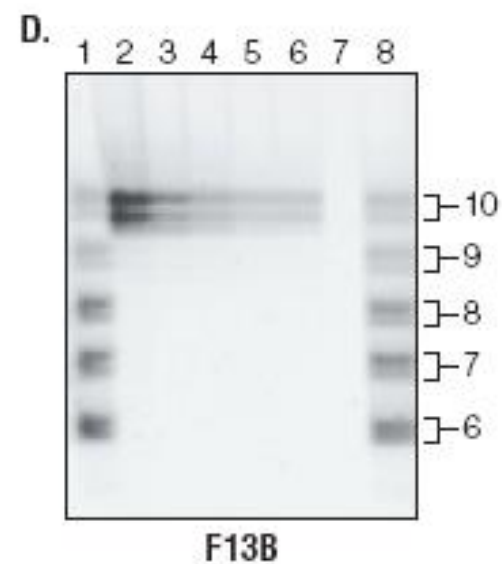
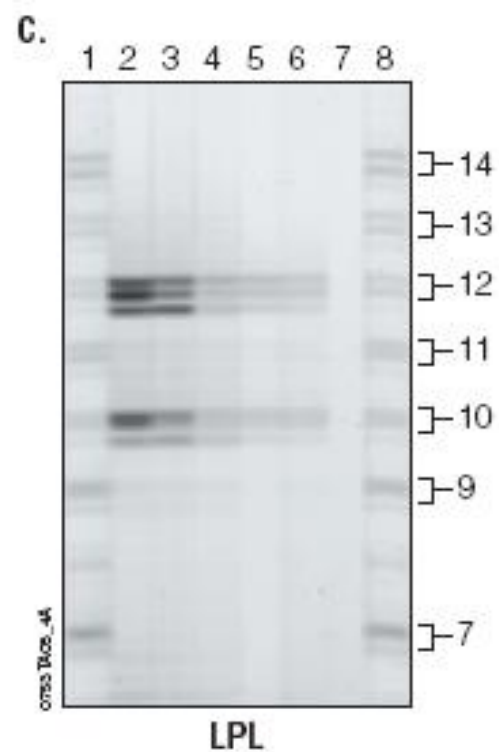
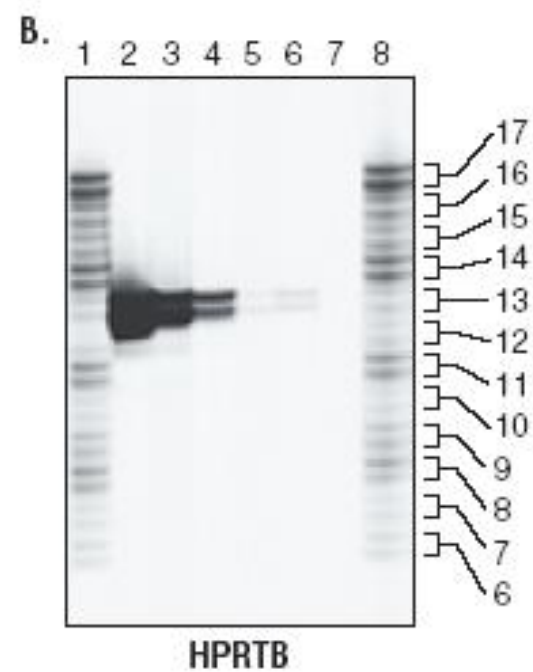
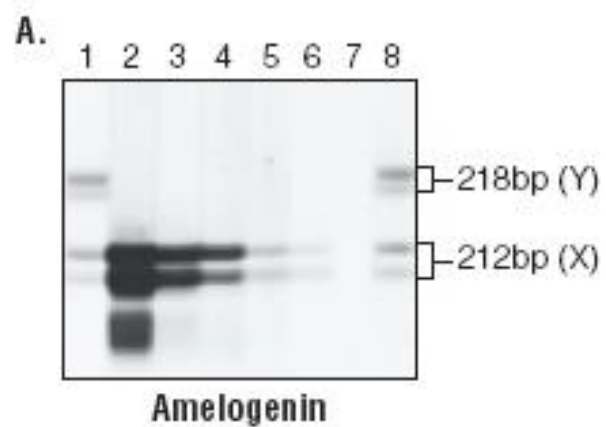

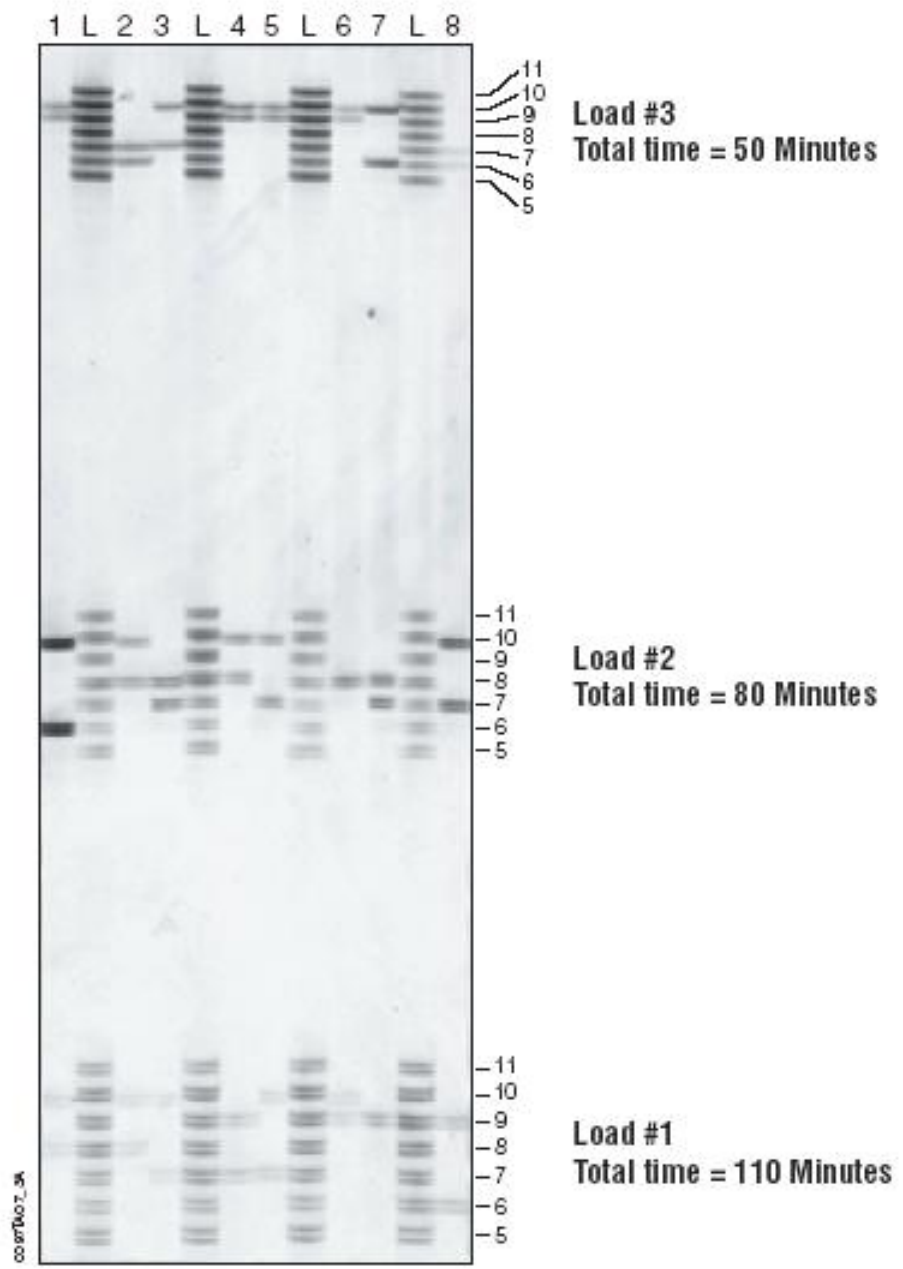

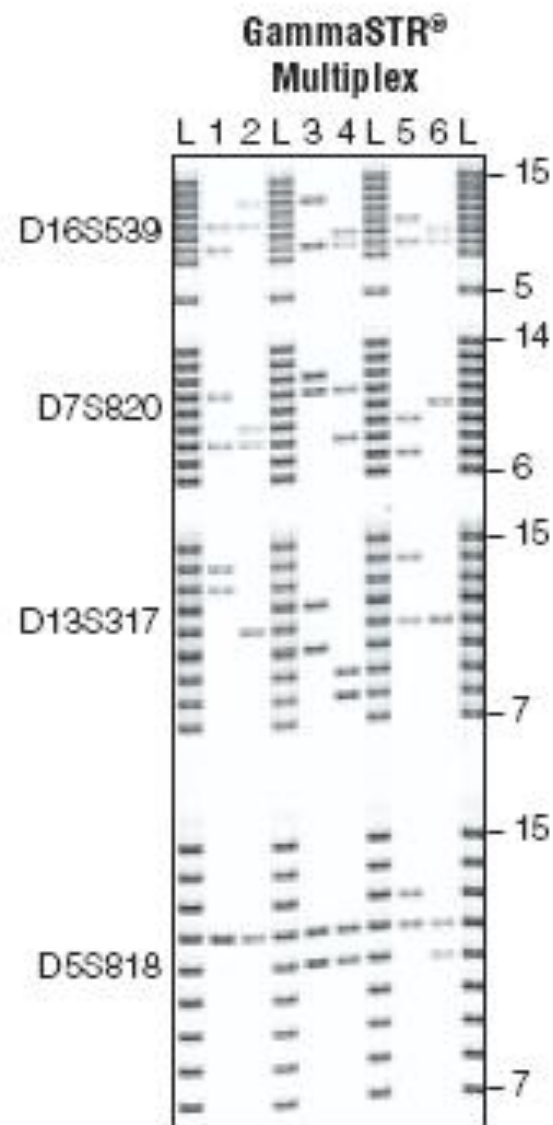
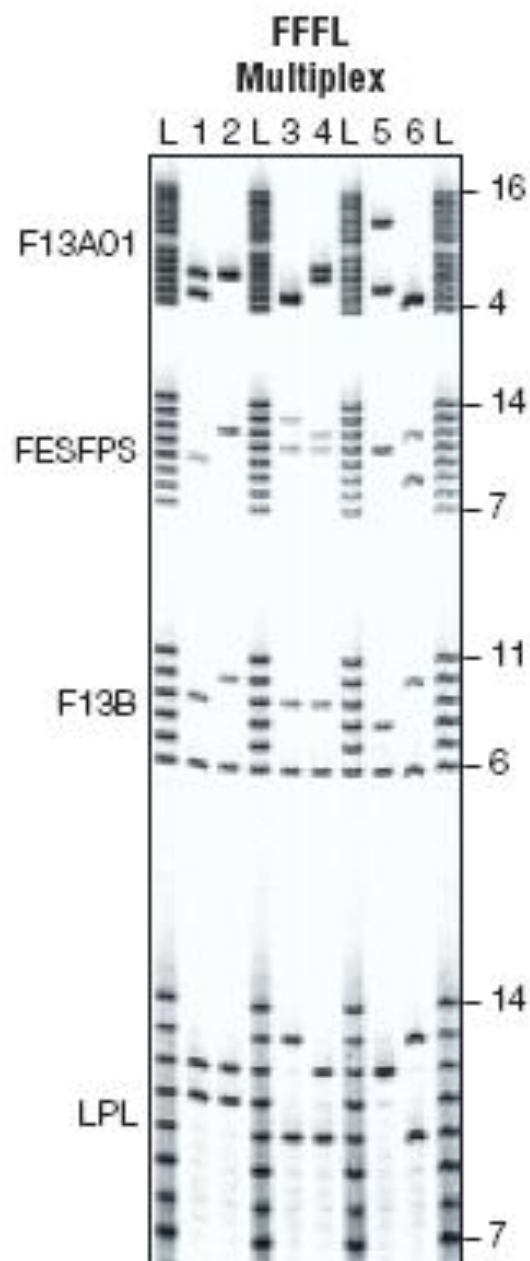
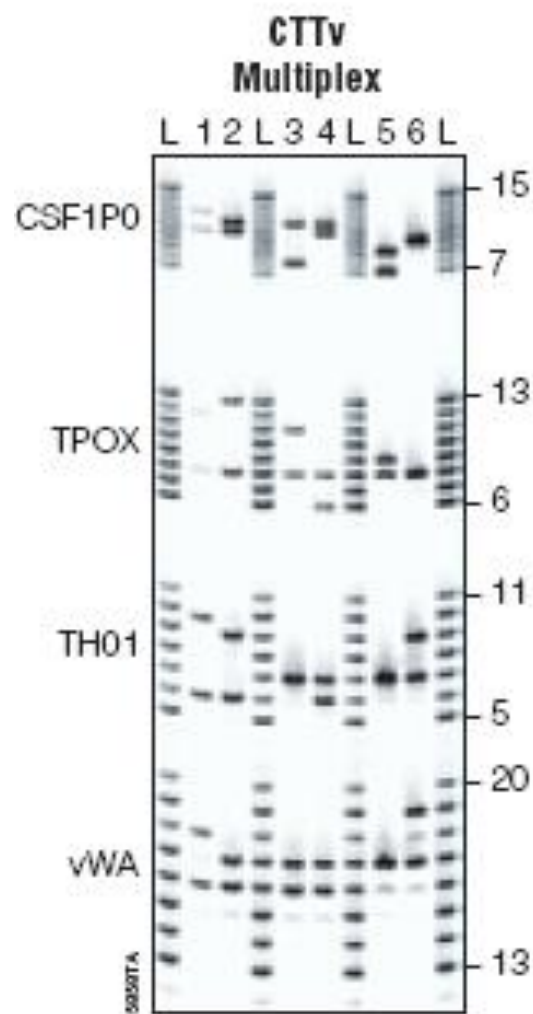

DNA Separation Mechanism



- Size based separation due to interaction of DNA molecules with entangled polymer strands
- Polymers are **not cross-linked** (as in slab gels)
- “Gel” is **not attached** to the capillary wall
- **Pumpable** -- can be replaced after each run
- Polymer length and concentration determine the separation characteristics

CE Animation

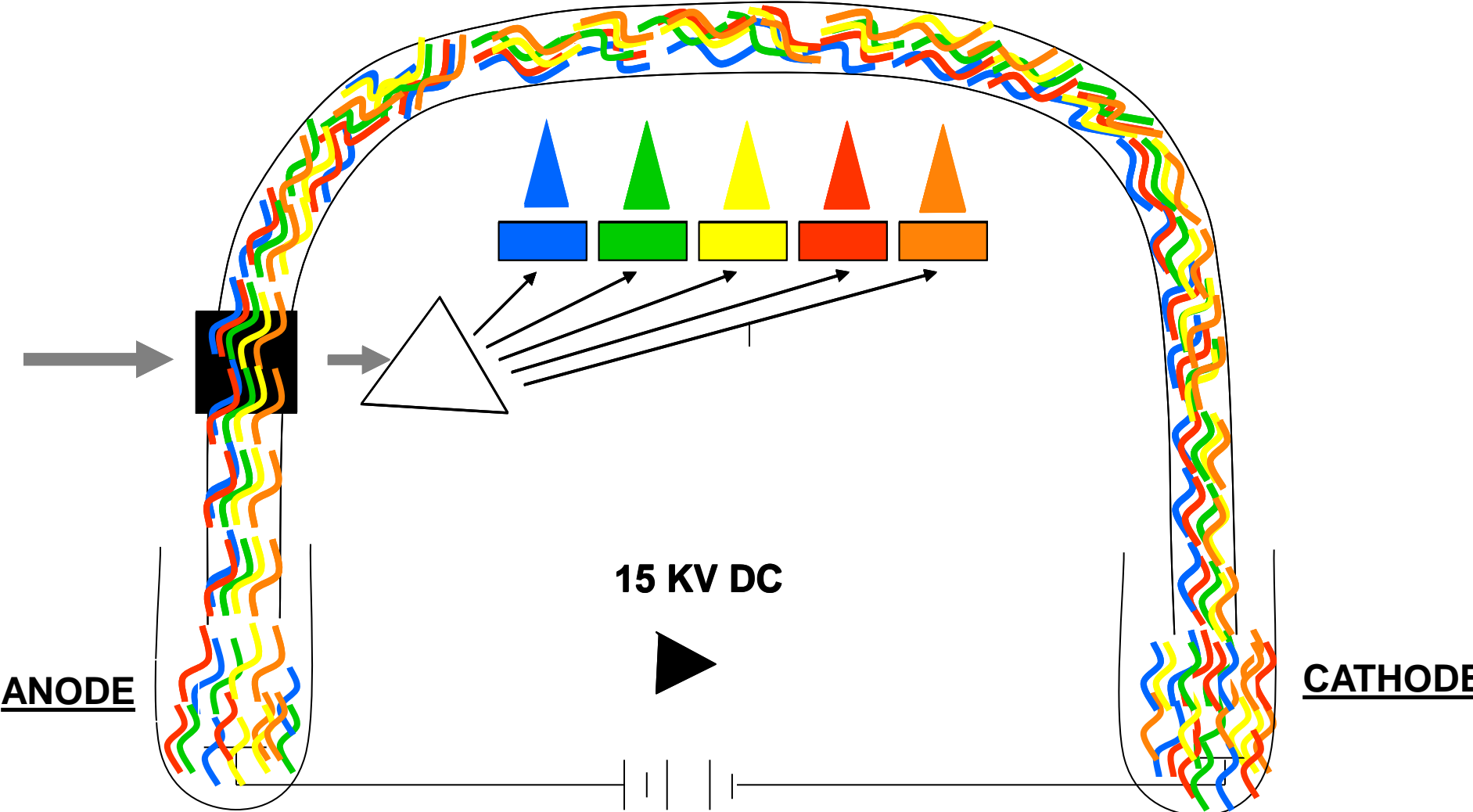

AmpFISTR®
Identifiler™

6FAM
(blue)

VIC
(green)

NED
(yellow)

PET
(red)

LIZ
(orange)

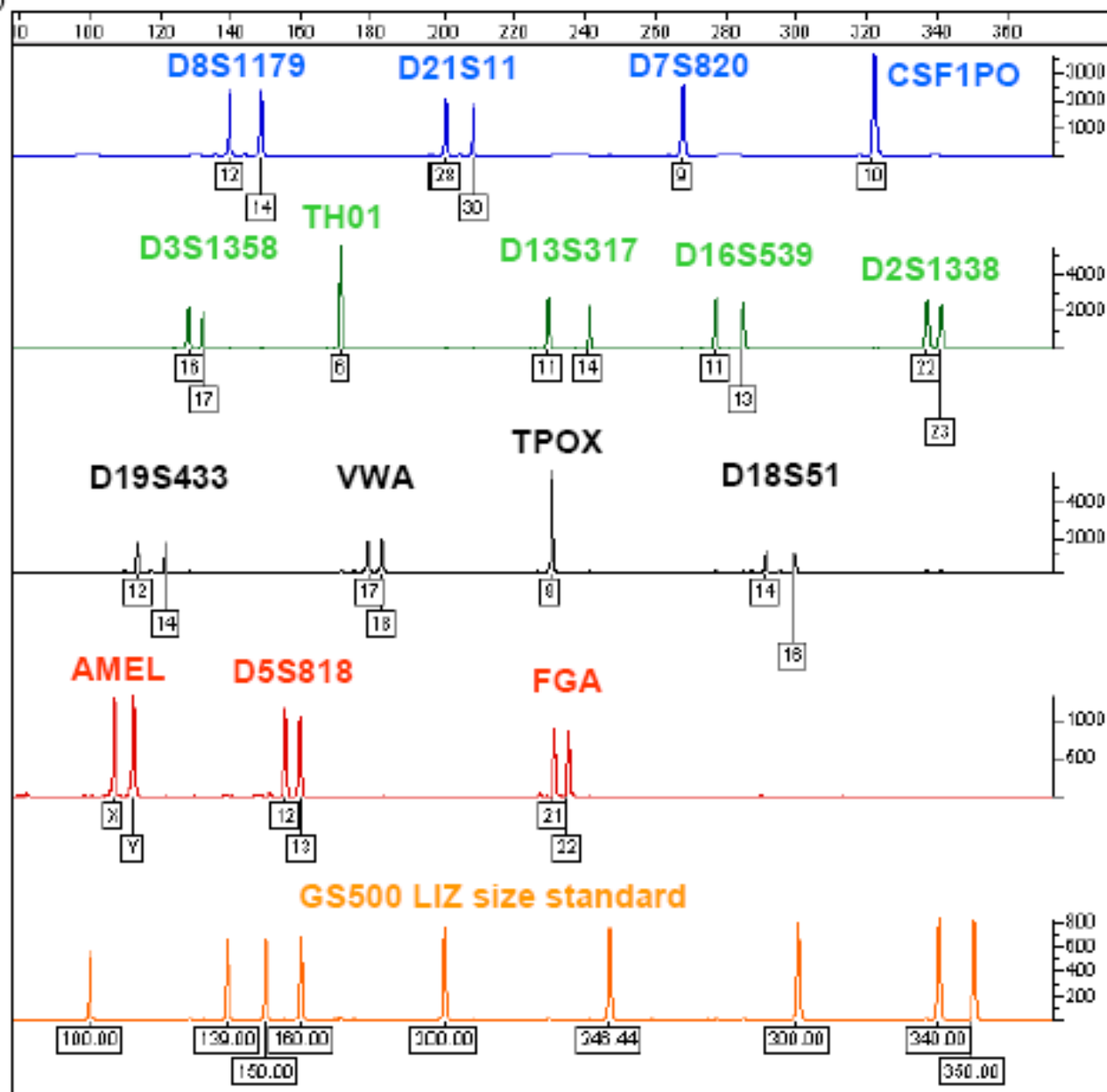

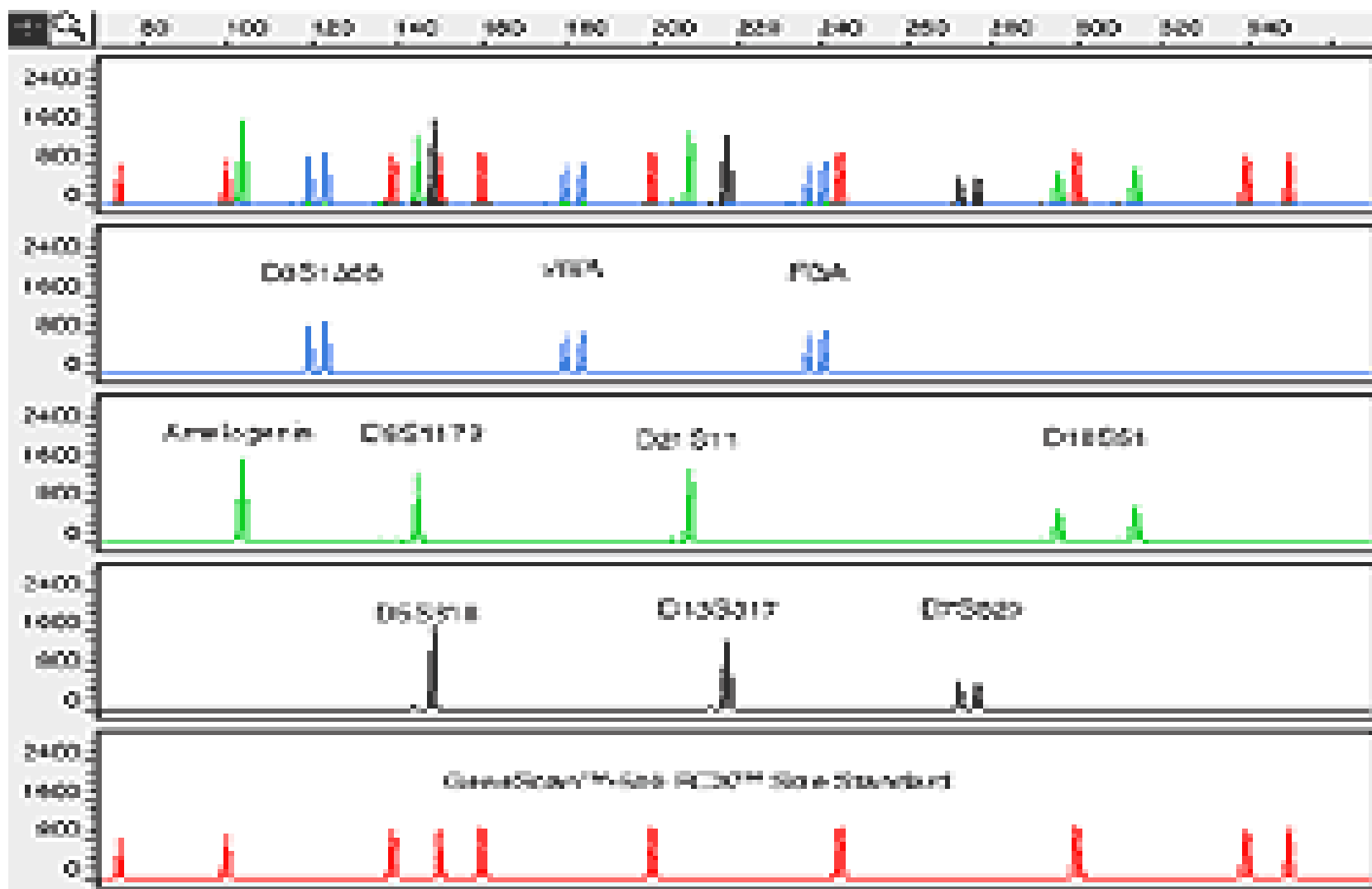

Human Identity Testing with Multiplex STRs

AmpFISTR® SGM Plus™ kit

100 125 150 175 200 225 250 275 300 325

DNA Size (base pairs)

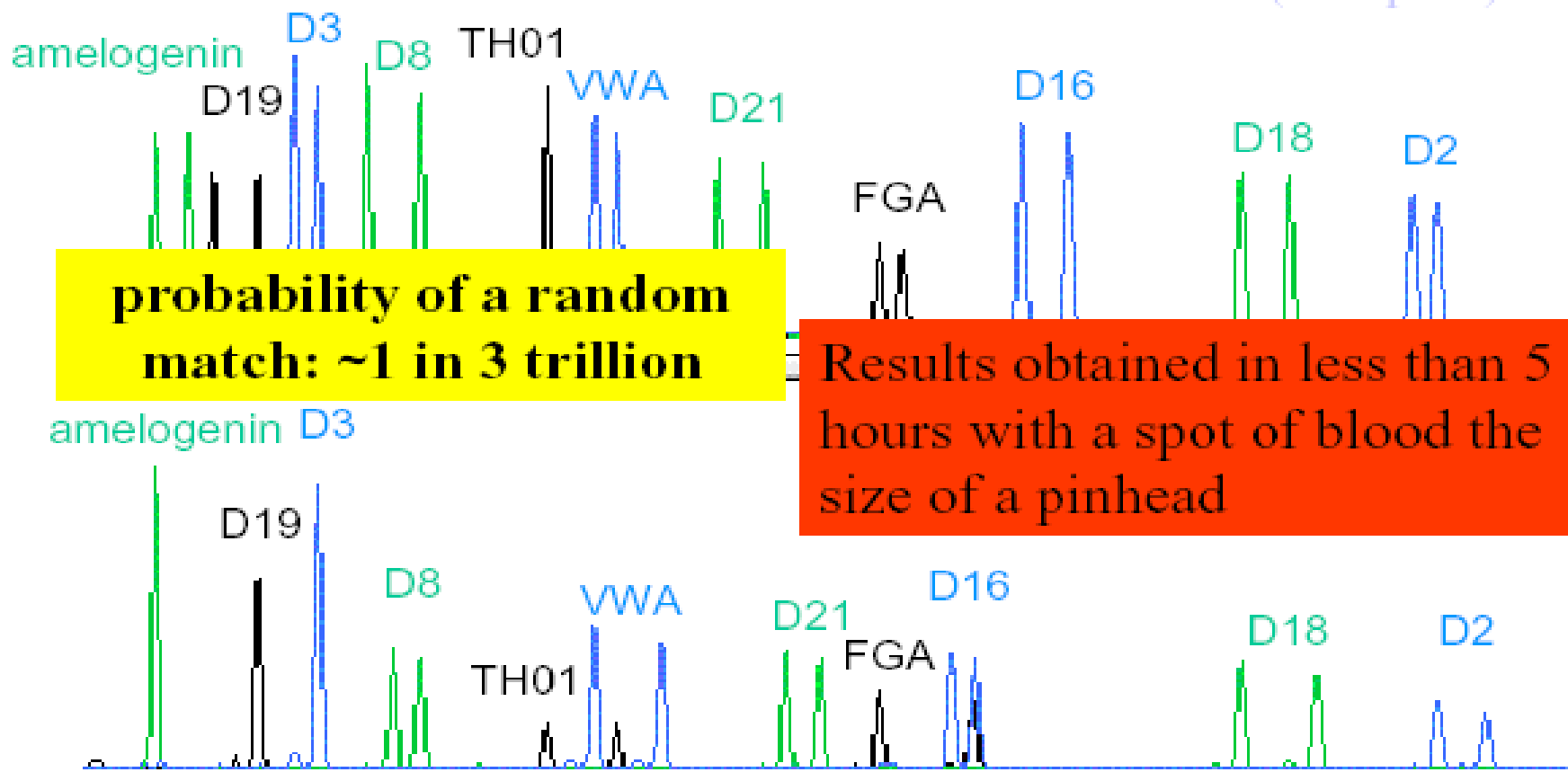

Simultaneous Analysis of 10 STRs and Gender ID

- Match probabilities obtained with STR profiling are so low that their reciprocals vastly exceed the entire human population.

13 Locus STR Profile

Discriminating power

1 in 837 trillion

These values are for unrelated individuals
assuming no population substructure (using only p^2 and $2pq$)

| S.No. | STR Profile | Freq. in population |
|--------------|--------------------|-----------------------------------|
| 1. | 15,15 | 0.27 x 0.27 = 0.073 |
| 2. | 14,18 | 0.14 x 0.18 x 2 = 0.05 |
| 3. | 22,26 | 0.17 x 0.207 x 2 = 0.07 |
| 4. | 13,16 | 0.34 x 0.088 x 2 = 0.023 |
| 5. | 31,32 | 0.109 x 0.142 x 2 = 0.026 |
| 6. | 14,17 | 0.298 x 0.065 x 2 = 0.038 |
| 7. | 8,10 | 0.007 x 0.137 x 2 = 0.0019 |
| 8. | 11,12 | 0.277 x 0.264 x 2 = 0.146 |
| 9. | 8,11 | 0.215 x 0.230 x 2 = 0.0989 |
| 10. | 8,8 | 0.154 x 0.154 = 0.023 |
| 11. | 8,10 | 0.412 x 0.124 x 2 = 0.10 |
| 12. | 10,11 | 0.198 x 0.264 x 2 = 0.10 |

Combined frequency = 3.6×10^{-17}

| S.No. | Gene/Locus | No. of Repeats | Possible Comb. |
|--------------|-------------------|-----------------------|-----------------------|
| 1. | CSF1PO | 7 to 15 | 45 |
| 2. | TPOX | 6 to 13 | 36 |
| 3. | THO1 | 5 to 11 | 28 |
| 4. | vWA | 13 to 20 | 36 |
| 5. | F13A01 | 4 to 16 | 91 |
| 6. | FESFPS | 7 to 14 | 36 |
| 7. | F13B | 6 to 11 | 21 |
| 8. | LPL | 7 to 14 | 36 |
| 9. | D16S539 | 5 to 15 | 66 |
| 10. | D7S820 | 6 to 14 | 45 |
| 11. | D13S317 | 7 to 15 | 45 |
| 12. | D58S18 | 7 to 15 | 45 |
| 13. | Amelogenin | - | XX or XY |

| STR | Mother | Child | Father |
|---------|--------|-------|---------|
| DS1179 | 10,12 | 12,15 | 11,12 |
| D21S11 | 29,29 | 28,29 | 29,32.2 |
| D7S820 | 8,11 | 8,8 | 10,11 |
| CSF1PO | 9,12 | 9,12 | 12,13 |
| D3S1358 | 15,17 | 16,17 | 15,17 |
| TH01 | 6,7 | 6,9 | 6,6 |
| D13S317 | 8,12 | 8,8 | 9,11 |
| D16S539 | 13,13 | 10,13 | 12,13 |

| | | | |
|-------------|-------|-------|-------|
| D2S133 8 | 18,21 | 18,23 | 19,19 |
| D19S41 3 | 14,14 | 14,15 | 14,15 |
| vWA | 16,19 | 16,16 | 17,17 |
| TPOX | 8,11 | 10,11 | 11,11 |
| D18S51 | 13,14 | 13,15 | 15,18 |
| D5S818 | 11,12 | 12,12 | 11,12 |
| FGA | 22,24 | 24,25 | 23,25 |
| AMEL | XX | XX | XY |

New Technologies for Forensic DNA Testing

- Additional STR Markers
- Mini STRs
- Mt DNA
- DNA Phenotyping
- SNP markers
- DNA chip
- CpG markers
- RNA profiling

- DNA has long been used to implicate or exonerate individual suspects
- Phenotyping is a more predictive method by which investigators can narrow or broaden their suspect searches, based on general categories of physical traits.
- Law enforcement can now publicly announce that they are looking for a suspect who “probably” has dark skin, or who “probably” has blue eyes, and so on.

Lineage DNA markers

STR markers on non-sex chromosomes (X & Y) and polymorphic DNA sequence of mitochondrial DNA are used for

- criminal casework, identification of victims in mass disasters, or paternity/immigration disputes.
- These markers have also been used for evolutionary purposes to reconstruct the movement of man since leaving Africa some 90,000 years ago.
- In some kinship analyses involving maternal relatives, mitochondrial DNA analysis is also being used.

Y-STR markers

- Y chromosome is transmitted from father to son, hence all male siblings share the same Y chromosome and are transferred from one generation to the next, to the next, to the next and so on.
- A set of 16 to 23 such male-specific STRs are in use particularly in sexual assaults and in determining paternal lineage of a person.

X-STR markers

- A large number of short tandem repeats (STR) markers on the human X chromosome have been described and established for use in forensic genetic testing.
- These markers located on X chromosome have a particular inheritance pattern,, women are dizygous and men are hemizygous, with the latter receiving the single X from the mother similarly father transmit their X chromosome to daughter as haplotypes.
- Analysis of X-chromosomal loci is beneficial in deficiency paternity cases, where half-sister and/or grandmothers are examined.
- 12 STR marker multiplex STR kit is available which can amplify 12 markers in a single reaction.

Mitochondrial DNA

- Highly compromised samples which contain damaged, degraded, and/or low quality DNA fail to be characterised by normal autosomal STR markers.
- In such cases analysis of mitochondrial DNA (mtDNA) can prove to be a valuable tool.

- Mitochondrial DNA is inherited down the maternal line and is particularly useful in cases of missing persons when maternal relatives separated by several generations can act as reference samples.
- The use of mitochondrial DNA analysis is still not that common and most of the forensic laboratories

DNA Methylation in Forensics

1. Authentication of DNA samples
2. Age prediction
3. Tissue sources and body fluid identification
4. Differentiating monozygotic twins

In cases where identical twins are involved, DNA methylation provides an attractive alternative for positive identification. This is good news for crime fighters.

DNA methylation analysis can be used to complement and enhance DNA fingerprinting and other currently existing forensic technologies.

- DNA Evidence gained legal validity in India in 1989 in a paternity case (Anil Kumar Vs Turaka Kondala Rao, 1998 Cr.LJ4279(AP)).

Limitations

1. Unavailability of suspect specimen
2. Refusal by suspect to provide blood sample
3. Potential problem over which analyst has little control
 - Insufficient specimen
 - Specimen degradation
 - Contamination
 - Mutation (1 in 1,00,000 in one generation at any locus)
 - Population allele frequency

DNA-Window to the Past

Hunting for ancient DNA molecules is exciting field for DNA technologist

- 1985: DNA from 2400 yrs old Egyptian mummy's amplified and sequenced for 3400 bases.
- 1989: DNA extracted from 5500 yrs old human bones.
- 1991: DNA extracted from 18 million yrs old fossilized Magnolia leaves.
- 1992 :DNA extracted from 30 million yrs old fossilized bee and termite. DNA of 14,000 yrs cat was sequenced.

- 1993-94 : DNA extracted from 65 and 80 million yrs old dinosaur
- 1994 : DNA extracted from 25 million yrs old spores of Bacillus Bacteria
- 1998 :From fossilized dung of extinct giant sloth which matched with DNA of modern sloth.

- DNA has been cloned from extinct animals (Quagga) and plant(18 million yrs. old magnolia leaves
- Mt. DNA studies support the origin of human in Africa –200,000 yrs. ago.
- DNA studies revealed that Neanderthals were not on direct line of succession to modern human.
- Analysis of Mt DNA of Skeleton of early farmers of Neolithic or New Stone Age (who brought agriculture about 7500 yrs. ago) from 16 locations in Germany, Austria and Hungary showed that they did not leave much genetic mark on the modern European population.

Roots of European ancestry traced to Old Stone Age (Paleolithic hunter-gatherers who arrived in Europe around 40,000 yrs. ago.)

Thus, ability to retrieve DNA from ancient materials and museum specimens gives archeologists, anthropologists a glimpse of ancient life and important information for evolutionary events.

Information on 13 CODIS STRs

| Locus Name | Chromosomal Location | Repeat Motif ISFH format | GenBank Accession | Allele in GenBank | Allele Range | Number of Alleles Seen* |
|------------|----------------------|--------------------------|-------------------|-------------------|--------------|-------------------------|
| CSF1PO | 5q33.3-34 | TAGA | X14720 | 12 | 6-16 | 15 |
| FGA | 4q28 | CTTT | M64982 | 21 | 15-51.2 | 69 |
| TH01 | 11p15.5 | TCAT | D00269 | 9 | 3-14 | 20 |
| TPOX | 2p23-pter | GAAT | M68651 | 11 | 6-13 | 10 |
| VWA | 12p12-pter | [TCTG][TCTA] | M25858 | 18 | 10-24 | 28 |
| D3S1358 | 3p | [TCTG][TCTA] | NT_005997 | 18 | 9-20 | 20 |
| D5S818 | 5q21-31 | AGAT | G08446 | 11 | 7-16 | 10 |
| D7S820 | 7q11.21-22 | GATA | G08616 | 12 | 6-15 | 22 |
| D8S1179 | 8 | [TCTA][TCTG] | G08710 | 12 | 8-19 | 13 |
| D13S317 | 13q22-31 | TATC | G09017 | 13 | 5-15 | 14 |
| D16S539 | 16q24-qter | GATA | G07925 | 11 | 5-15 | 10 |
| D18S51 | 18q21.3 | AGAA | L18333 | 13 | 7-27 | 43 |
| D21S11 | 21q21 | Complex [TCTA][TCTG] | AP000433 | 29 | 24-38 | 70 |

Probability of a Random Match Using 13 CODIS STR Markers

| STR Marker | #Alleles | Random match probability (FBI Caucasian) |
|------------|----------|--|
| CSF1PO | 11 | 0.112 |
| FGA | 19 | 0.036 |
| TH01 | 7 | 0.081 |
| TPOX | 7 | 0.195 |
| VWA | 10 | 0.062 |
| D3S1358 | 10 | 0.075 |
| D5S818 | 10 | 0.158 |
| D7S820 | 11 | 0.065 |
| D8S1179 | 10 | 0.067 |
| D13S317 | 8 | 0.085 |
| D16S539 | 8 | 0.089 |
| D18S51 | 15 | 0.028 |
| D21S11 | 20 | 0.039 |
| | | |
| | Product | 0.00000000000000001683 |
| | | |
| | One in | 594,059,679,247,540 |
| | | 1 in 594 trillion |

DNA EVIDENCE-Sci. Value

Earlier Fingerprints & Blood Groups were being used for identification /discrimination.

Use of DNA has strengthened the analytical value of evidence material in identifying the individuals involved in crime, dead in mass disasters and unidentified bodies which helps in effective and speedy administration of justice

Evaluating weight of DNA evidence

Evidential weight of a match between crime stain profile and suspect profile is quantified by match probability (p_m) i.e. chance of two unrelated people sharing a profile (calculated by multiplying the individual allele frequencies in the profile in question).

More loci & greater heterozygosity of each locus
–Lower the value of p_m

P_m increases if :

Profile is partial due to degradation reducing no. of informative loci.

Suspect and perpetrator share many alleles by descent (brothers).

Suspect and perpetrator originate from the same subpopulation.

- According FBI(1997) :

If the estimated probability of DNA profile found in a crime sample is less than 1

in 260 billion, and it is seen in a person, then that person is the source of the sample.

- Identification of the body fluid origin of dried forensic biological material (blood, semen, saliva, vaginal secretions and menstrual blood) involves expression profiling of body fluid specific messenger and small RNAs (mRNA and miRNA).
- RNA analysis may permit not only a molecular-based approach with a greater specificity than that of conventional methodologies for the identification of forensically relevant biological fluids, but may also provide strategies particularly suited for the analysis of environmentally impacted or degraded samples frequently encountered in forensic casework.

- Messenger RNA is a temporary copy of DNA used in the synthesis of proteins. Once it accomplishes its task it begins deteriorating.
- Depending on the type of mRNA it can last anywhere from several hours to several weeks, contrarily to DNA that remains intact

- DNA has its limits, as it cannot date a stain of bodily fluid to help investigators determine when a crime was committed. But messenger ribonucleic acid (mRNA) can.
- Bodily fluids are the most common elements of proof on crime scenes

- **InnoTyper™ 21** – a small amplicon DNA typing system containing 20 Retrotransposable Insertion Polymorphism (RIP) markers and Amelogenin.
- This kit has amplicons ~60-125bp and can provide discriminating results from extremely low-level and/or degraded forensic samples including bone fragments or single hair shafts.
- The RIP markers in this kit provides valuable utility for difficult kinship, missing person and mass disaster victim identification cases.

Application of epigenetic markers in the identification of bio fluids that are commonly found at the crime scene

- DNA methylation in body fluid identification
- Age determination of the donor of biological evidence,
- Parentage testing and personal identification,
- Differentiation between monozygotic twins due to their different DNA methylation patterns.
- Artificial DNA detection

- Age predictions correlate with telomere length
- Telomere length is well known to decline during aging - an average of 39 bp per year in granulocytes - and this approach can also be used to estimate donor age
- The precision of age predictions based on telomere length was relatively low

- 'Biological age' is influenced by additional parameters such as genetic background, disease and lifestyle.
- Biomarkers for biological aging are relevant for geriatric assessment and may support the adaptation of habits to assist healthy aging. Leukocyte telomere length has been suggested as a marker for biological age.

- In fact, telomere attrition seems to be enhanced by various parameters, such as obesity and cigarette smoking . Several other molecular methods can be used to estimate human age, including analysis of age-dependent deletions of mitochondrial DNA
- Epigenetic aging signature provides a simple biomarker to estimate the state of aging in blood

- Human aging is associated with DNA methylation changes at specific sites in the genome.
- These epigenetic modifications may be used to track donor age for forensic analysis or to estimate biological age.

- Genetics is a new field of applied science that will have a huge impact on the security of citizens.
- However, genetic methods to identify offenders and the creation of national DNA databases pose the possibility of violation of privacy rights.
- Moreover, applications such as the use of genetics to predict a person's visible characteristics are subject to concern.

- Sets of messenger RNA (mRNA), microRNA (miRNA) and epigenetic DNA markers for the identification of human body fluids and tissues

- The methylation patterns can differentiate blood, sperm, and epithelial cells .
- Epigenetic markers as a novel tool for the determination of bio fluids .

- Non-human forensic genetics, including identification of bacteria and viruses, animals and plants.

The Veterinary Genetics

- **Animals can be the Victim**
- Animal cruelty
- Identifying the remains of a lost pet
- Theft of an animal
- **Animals can be the Perpetrator**
- Identification of an animal involved in an attack on a person or other animal
- Identification of an unrestrained animal causing an accident
- Identification of an animal responsible for property damage
- **Animals can be the Witness**
- Animal DNA can link a suspect with a crime scene or victim. Transfer of DNA from hair, saliva, blood, urine, or feces can occur during the commission of a crime—from the victim's pet to the suspect or crime scene, and from the suspect's pet to the victim or crime scene.

Future Developments

Hand- held-device (lab. on chip) for rapid DNA profiling at S.O.C. Single integrated platform which can extract, amplify and sequence DNA have been developed.

STR typing from single cell (1ng=200 cell) pm 1 in 50 million

DNA Profiling Report in the Court

- The report of DNA testing duly signed & stamped by Examining Scientist(s) should be sent to the forwarding authority only in a sealed cover to maintain the confidentiality of the result.
- The report should include the details of the date(s) of the receipt of samples into the laboratory and case details, sample description/source of the sample etc.
- Report should contain the details of the kit(s) and software used.

- Result of the examination of each sample analysed and the necessary comparison of samples carried in the test.
- Which samples were taken for examination & Why the other samples were not taken for examination
- The probability of match in case of rape cases and paternity index in case of paternity cases by the use of the frequencies of the DNA sample from the available data base should be included.
- The report should contain the definite opinion about the result of the examination like, whether the accused/suspect can be excluded or cannot be excluded.
- Finally, the list of enclosures attached to the report viz., electropherograms, allelic data if any.

Form No. FSD-CH/FM/40 Dt. 19/05/2022



தடய அறிவியல் ஆய்வறிக்கை
Forensic Examination Report



தடய அறிவியல் துறை
(தலைமை ஆய்வகம்)

TC-10611

'பாரன்சிக் ஹவுஸ்', 30A, காமராசர் சாலை, மைலாப்பூர், சென்னை-600004

FORENSIC SCIENCES DEPARTMENT
(Main Laboratory)

'Forensic House', 30A, Kamarajar Salai, Mylapore, Chennai-600 004

* ஐந்தெட்டு எழுத்துகள்

ஐந்தெட்டு எழுத்துகள்

* Report No: T.No.xx/2022 DNA/PAT/xx/2022

Dated: 0x.06.2022

இயக்குநர், தடய அறிவியல் துறை, 30A, காமராசர் சாலை, மைலாப்பூர், சென்னை-600 004, அவர்களுக்கு, வழக்கு தொடர்பான நீதிமன்ற விசாரணைகளின் முடிவுகள் அறிவிக்கப்படவேண்டும். (1962 ஆம் ஆண்டு சூலைத் திங்கள் 16 ஆம் நாளிட்ட உள் துறை அரசு நிலையாணை எண் 2408 மற்றும் 1968 ஆம் ஆண்டு சூலைத் திங்கள் 29 ஆம் நாளிட்ட உள் துறை அரசு நிலையாணை எண் 2158 ஆகியவற்றைக் காண்க.)

The result of the Judicial inquiries into the case should be reported to the Director, Forensic Sciences Department, 30A, Kamarajar Salai, Mylapore, Chennai-600 004, vide G.O. Ms. No. 2408, Home, dated 16th July 1962 and G.O. Ms. No.2158, Home, dated 29th July 1968.

அனுப்புநர்: இயக்குநர், தடய அறிவியல் துறை, 'பாரன்சிக் ஹவுஸ்', 30A, காமராசர் சாலை, மைலாப்பூர், சென்னை --600 004.

From: The Director, Forensic Sciences Department, 'Forensic House', 30A, Kamarajar Salai, Mylapore, Chennai-600 004.

ஐந்தெட்டு எழுத்துகள்: Sessions Judge,

To: Special Court for Exclusive Trial of
Cases under POCSO Act,

XXX (P.A.C.)

A paper cover containing the following items was received for DNA analysis on 12.01.2022 through WHC 1xx Ms A xxxx under correct seals.

Item 1: A white pouch enclosing a blood card with blood stains and marked, "----- 21/M".

Item 2: A white pouch enclosing a blood card with blood stains and marked, "----- 2 month/mch".

Item 3: A white pouch enclosing a blood card with blood stains and marked, "----- 16/F".

REPORT: DNA was extracted from each of the above blood samples and amplified for 15 STR loci using PCR amplified STR technique after taking due care for the integrity of each sample. The blood samples were analysed from xx.0x.2022 to xx.0x.2022 and labelled as (i) Alleged Father - DNA_PAT_xx_2022_AF_M (ii) Child - DNA_PAT_xx_2022_C_T (iii) Biological Mother - DNA_PAT_xx_2022_BM_T.

A comprehensive analysis of the test results of the above samples and the interpretations thereof is given in the enclosed annexure. From the comprehensive analysis of the test results as shown in the annexure, the Alleged Father Mr. Xxxxx is not found excluded from the paternity of the Child Xxxxx under any of the 15 STR loci tested. Hence the cumulative probability of paternity of Mr. Xxxxx for being the father of the Child Xxxxx and the cumulative chance of exclusion of any random man from the paternity of the Child Xxxxx were computed.

- (i) the cumulative probability of paternity of Mr. Xxxxx for being the father of the Child Xxxxx is found to be 99.9999999%.
- (ii) the cumulative chance of exclusion of any random man from the paternity of the Child Xxxxx is 99.9999999999999%.

Conclusion: From the DNA typing results of the above samples, it is found that in the absence of identical twins, Mr. Xxxxx is the Biological Father of the Male Child Xxxxx.

Note:

1. This report may be used as evidence in any inquiry, trial or other proceedings as per Sec.293 CrPC.
2. Result/opinion relates only to the items examined.
3. Report shall not be reproduced except in full, without the written approval of the Director, Forensic Sciences Department, Chennai.
4. Reference to procedure used: Working Procedure Manual - Forensic DNA, Forensic Sciences Department (Main Laboratory), Chennai-4.

Forensic Sciences Department, Chennai - 600 004.
DNA Typing Unit

No.DNA/PAT/XX/2022

Comprehensive Analysis of the test results

| Sl. No. | STR Locus Tested | Genotype | | | Cumulative probability of paternity of Alleged Father Mr.XXX | Cumulative chance of exclusion of Random man % |
|---------|------------------|-----------------------|-------------|--------------------------|--|--|
| | | Alleged Father Mr.XXX | Child Xxxxx | Biological Mother Ms.XXX | | |
| 1 | D8S1179 | 11,12 | 12,14 | 12,14 | 94.34 | 98.50 |
| 2 | D21S11 | 28,30 | 30,32.2 | 31,32.2 | 97.71 | 99.85 |
| 3 | D7S820 | 8,12 | 8,8 | 8,8 | 99.02 | 99.96 |
| 4 | CSF1PO | 10,11 | 11,11 | 11,12 | 99.37 | 99.99 |
| 5 | D3S1358 | 15,16 | 16,18 | 15,18 | 99.70 | 99.999 |
| 6 | TH01 | 7,10 | 7,10 | 7,9 | 99.97 | 99.9999 |
| 7 | D13S317 | 9,12 | 9,12 | 9,12 | 99.98 | 99.99999 |
| 8 | D16S539 | 11,14 | 11,12 | 10,12 | 99.99 | 99.999999 |
| 9 | D2S1338 | 18,25 | 18,20 | 18,20 | 99.9991 | 99.99999993 |
| 10 | D19S433 | 14,15.2 | 14,14 | 14,14 | 99.9993 | 99.999999997 |
| 11 | vWA | 16,16 | 16,18 | 18,18 | 99.9998 | 99.999999994 |
| 12 | TPOX | 8,11 | 8,11 | 11,11 | 99.99992 | 99.999999998 |
| 13 | D18S51 | 14,16 | 16,19 | 16,19 | 99.99997 | 99.999999999 |
| 14 | D5S818 | 12,12 | 12,12 | 12,12 | 99.999999 | 99.99999999999 |
| 15 | FGA | 19,21 | 19,19 | 19,26 | 99.9999999 | 99.999999999999 |

Note: The numbers given under genotype represent the nomenclature of alleles under the locus

No.DNA/PAT/XX/2022

Inference: In a child, under each of the STR locus, one allele should be contributed by the biological mother (maternal) and the other allele should be contributed by the biological father (paternal).

1. Of the two alleles under each of the 15 STR loci found in the Child Xxxxx, one allele (maternal) was contributed by the Biological Mother Ms.xxxx and hence the other allele (paternal) is ought to have been contributed by the father to this child.
2. All such paternal alleles which ought to have been contributed by the father to the Child Xxxxx are found to be present in the Alleged Father Mr.Xxxxx.
3. Apart from the alleles accounted as present either in the Biological Mother Ms.xxxx or in the Alleged Father Mr.Xxxxx, no other unaccounted allele is present in the Child Xxxxx.
4. Since the Alleged Father Mr.Xxxxx is not found excluded from the paternity of the child Xxxxx under any of the 15 STR loci tested, his probability of paternity has been computed.
5. The cumulative probability of paternity of the Alleged Father Mr.Xxxxx, for being the father of the Child Xxxxx is 99.9999999%
6. The cumulative chance of exclusion of any random man from the paternity of the Child Xxxxx is 99.9999999999999%.



தடய அறிவியல் ஆய்வறிக்கை
Forensic Examination Report



TC-10611

'பாரன்சிக் ஹவுஸ்', 30A, காமராசர் சாலை, மைலாப்பூர், சென்னை-600004

FORENSIC SCIENCES DEPARTMENT
(Main Laboratory)

'Forensic House', 30A, Kamarajar Salai, Mylapore, Chennai-600 004

* ஐந்தெழுத்து எண்

ஐந்தெழுத்து

* Report No: T.No.xx/2022 DNA/PAT/xx/2022

Dated: 0x.06.2022

இயக்குநர் தடய அறிவியல் துறை 30A, காமராசர் சாலை, மைலாப்பூர், சென்னை-600 004, அவர்களுக்கு வழக்கு தொடர்பான நீதிமன்ற விசாரணைகளின் முடிவுகள் அறிவிக்கப்படவேண்டும். (1962 ஆம் ஆண்டு சூலைத் திங்கள் 16 ஆம் நாளிட்ட உள் துறை அரசு நிலையாணை எண் 2408 மற்றும் 1968 ஆம் ஆண்டு சூலைத் திங்கள் 29 ஆம் நாளிட்ட உள் துறை அரசு நிலையாணை எண் 2158 ஆகியவற்றைக் காண்க.)

The result of the Judicial inquiries into the case should be reported to the Director, Forensic Sciences Department, 30A, Kamarajar Salai, Mylapore, Chennai-600 004, vide G.O. Ms. No. 2408, Home, dated 16th July 1962 and G.O. Ms. No.2158, Home, dated 29th July 1968.

அனுப்புநர்: இயக்குநர் தடய அறிவியல் துறை 'பாரன்சிக் ஹவுஸ்', 30A, காமராசர் சாலை, மைலாப்பூர், சென்னை -600 004.

From: The Director, Forensic Sciences Department, 'Forensic House', 30A, Kamarajar Salai, Mylapore, Chennai-600 004.

ஐந்தெழுத்து: Sessions Judge,

To: Special Court for Exclusive Trial of
Cases under POCSO Act,
XXX (FAC),
XXX District.

A paper cover containing the following items was received for DNA analysis on 21.01.2022 through WPC GrI 1xx2 Ms.S.xxx under correct seals.

Item 1: A white pouch enclosing a blood card with blood stains and marked, "Xxxxx 26/M DNA 74/21 31.12.2021 Xxx GMC, xxx".

Item 2: A white pouch enclosing a blood card with blood stains and marked, "B/o Xxxxx 29 days old/Mch DNA 75/21 31.12.2021 Xxx, xxx".

Item 3: A white pouch enclosing a blood card with blood stains and marked, "DNA 73/21 Date: 31.12.2021 Xxxxx 17/F Xxx, xxx".

REPORT: DNA was extracted from each of the above blood samples and amplified for 15 STR loci using PCR amplified STR technique after taking due care for the integrity of each sample. The blood samples were analysed from 25.04.2022 to 09.05.2022 and labelled as (i) Alleged Father - DNA_PAT_17_2022_AF_B (ii) Child - DNA_PAT_17_2022_C_BOY (iii) Biological Mother - DNA_PAT_17_2022_BM_M.

A comprehensive analysis of the test results of the above samples and the interpretation thereof is given in the enclosed Annexure. From the comprehensive analysis of the test results as shown in the annexure, it is found that under each of the nine STR loci i.e. D8S1179, D21S11, D3S1358, D13S317, D16S539, vWA, D18S51, D5S818 and FGA, the Alleged Father Mr.Xxxx is lacking an allele of a system which he ought to have contributed to the Male Child.

Further, under each of the seven STR loci (ie) D8S1179, D21S11, D3S1358, D13S317, vWA, D18S51 and FGA, the Male Child is lacking either of the alleles present in the Alleged Father Mr.Xxxxx.

The situation in which the alleged father is lacking an allele of a system that ought to have been contributed by him to the child and the situation in which the child lacks either of the alleles of the system present in the alleged father are the instances of definite exclusion of a non father from the paternity of the child.

Conclusion: From the DNA typing results of the above samples, it is found that the Alleged Father Mr.Xxxxx is excluded from the paternity of the Male Child.

Note:

1. This report may be used as evidence in any inquiry, trial or other proceedings as per Sec.293 CrPC. If evidence of the scientist is absolutely required as to the subject-matter of this report, summons may kindly be issued to Dr.M. Usha Rani, Scientific Officer well in advance, for deposing evidence.
2. Result/opinion relates only to the items examined.
3. Report shall not be reproduced except in full without the written approval of the Director

Comprehensive Analysis of the test results



| S.No | STR Locus Tested | Alleged Father Mr.Xxxxx | Male Child | Biological Mother Ms.Xxxxx | Remarks |
|------|------------------|-------------------------|------------|----------------------------|----------|
| 1 | D8S1179 | 10,15 | 12*,14 | 11,12 | * |
| 2 | D21S11 | 28,32.2 | 29*,30 | 29,32.2 | * |
| 3 | D7S820 | 8,11 | 11,12 | 9,12 | |
| 4 | CSF1PO | 11,12 | 12,12 | 10,12 | |
| 5 | D3S1358 | 17,19 | 15,16 | 15,16 | O |
| 6 | TH01 | 6,9 | 9,9 | 9,9 | |
| 7 | D13S317 | 11,12 | 8*,13 | 8,11 | * |
| 8 | D16S539 | 8,9 | 9*,11 | 8,9 | * |
| 9 | D2S1338 | 23,23 | 23,23 | 18,23 | |
| 10 | D19S433 | 13,14 | 13,14 | 13,15.2 | |
| 11 | VWA | 14,17 | 15*,16 | 14,15 | * |
| 12 | TPOX | 10,11 | 8,11 | 8,11 | |
| 13 | D18S51 | 15,15 | 14*,16 | 13,14 | * |
| 14 | D5S818 | 12,13 | 11,13* | 12,13 | * |
| 15 | FGA | 21,25 | 20.2,22* | 22,24 | * |

Note: The numbers given under genotype represent the nomenclature of alleles under the locus

Inference: In a Child, under each of the STR locus, one allele should be contributed by the biological mother (maternal) and the other allele should be contributed by the biological father (paternal).

- * In the Male Child, one of the alleles present in each of the eight STR loci (ie) D8S1179, D21S11, D13S317, D16S539, vWA, D18S51, D5S818 and FGA, is the maternal allele contributed by the Biological Mother Ms.Xxxxx.
- In the Male Child, either of the alleles present in the STR locus D3S1358 is the maternal allele contributed by the Biological Mother Ms.Xxxxx.

Hence, the other allele present in each of the above nine STR loci is ought to have been the paternal alleles contributed by the father to this Male Child. But these alleles are not present in the Alleged Father Mr.Xxxxx.

In view of the above observations, Mr. Xxxxx is excluded from being the father of the Male Child.

(Dr.N.Mahalakshmi, M.Sc.,Ph.D.)
Asst. Chemical Examiner to Govt. &
Deputy Director

(Dr.M.Usha Rani,M.Sc.,M.Phil.,Ph.D.,PGDCFS)
Scientific Officer



தடய அறிவியல் ஆய்வறிக்கை
Forensic Examination Report



TC-10611

தடய அறிவியல் துறை
(குலைமை ஆய்வகம்)
'பாரன்சிக் ஹவுஸ்', 30A, காமராசர் சாலை, மைலாப்பூர், சென்னை-
600004

FORENSIC SCIENCES DEPARTMENT
(Main Laboratory)

'Forensic House', 30A, Kamarajar Salai, Mylapore, Chennai-600 004

* ஐந்தெட்டு எழுத்து எண்

ஐந்தெட்டு எழுத்து

* Report No:

T.No.xx/2022 DNA/xx/2022

Dated: 0x.06.2022

இயக்குநர் தடய அறிவியல் துறை, 30A, காமராசர் சாலை, மைலாப்பூர், சென்னை-600 004, அவர்களுக்கு, வழக்கு தொடர்பான நீதிமன்ற விசாரணைகளின் முடிவுகள் அறிவிக்கப்படவேண்டும். (1962 ஆம் ஆண்டு சூலைத் திங்கள் 16 ஆம் நாள்ிட்ட உள் துறை அரசு நிலையாணை எண் 2408 மற்றும் 1968 ஆம் ஆண்டு சூலைத் திங்கள் 29 ஆம் நாள்ிட்ட உள் துறை அரசு நிலையாணை எண் 2158 ஆகியவற்றைக் காண்க.)

The result of the Judicial inquiries into the case should be reported to the Director, Forensic Sciences Department, 30A, Kamarajar Salai, Mylapore, Chennai-600 004, vide G.O. Ms. No. 2408, Home, dated 16th July 1962 and G.O. Ms. No.2158, Home, dated 29th July 1968.

அனுப்புநர்: இயக்குநர் தடய அறிவியல் துறை 'பாரன்சிக் ஹவுஸ்', 30A, காமராசர் சாலை, மைலாப்பூர், சென்னை --600 004.

From: The Director, Forensic Sciences Department, 'Forensic House', 30A, Kamarajar Salai, Mylapore, Chennai-600 004.

ஐந்தெட்டு எழுத்து: Sessions Judge,

To: Special Court for Exclusive Trial of
Cases under POCSO Act,
XXX (FAC),
XXX District.

A plastic bucket labelled, "CRIME NO: 196/2021 OF XXXX PS XXXX 15 YEARS/FEMALE MALE DEAD INFANT FOR DNA ANALYSIS" and containing a foetus in common salt was received for DNA analysis on 11.08.2021 through PC 1640 Mr.xxxx under correct seals.

REPORT:

DNA was extracted from the above item and amplified for amelogenin, i.e., sex locus and also for 15 STR loci using PCR amplified STR technique after taking due care for the integrity of the sample. The sample was analysed from 30.09.2021 to 01.11.2021.

The DNA typing results of the above item is given in the enclosed annexure. From the results of analysis as shown in the annexure, the gender of the foetus is found to be male.

A comprehensive analysis of the test results of the above item with that of alleged accused Mr.Xxx and biological mother Ms.Xxx and the interpretations thereof is given in this office report cited in ref 2.

The unexpended portion of the above item has been labelled as "DNA/XXX/2021" for identification.

Note:

1. This report may be used as evidence in any inquiry, trial or other proceedings as per Sec.293 CrPC. If evidence of the scientist is absolutely required as to the subject-matter of this report, summons may kindly be issued to Dr.M.Usha Rani, Scientific Officer well in advance, for deposing evidence.
2. Result relates only to the items examined.
3. Report shall not be reproduced except in full, without the written approval of the Director, Forensic Sciences Department, Chennai.
4. Reference to procedure used: Working Procedure Manual – Forensic DNA, Forensic Sciences Department (Main Laboratory), Chennai-4.

(Dr.N.Mahalakshmi, M.Sc., Ph.D.)
Asst. Chemical Examiner to Govt. &
Deputy Director

(Dr.M.Usha Rani, M.Sc., M.Phil., Ph.D., PGDCFS)
Scientific Officer

Copy to:

1. Sessions Judge,

No.DNA/XXX/2021

Name of the item : Foetus
Received on : 11.08.2021
Brought by : PC 164x, Mr.Xxxx
Label given : DNA_xx_2021

DNA Typing Results for Foetus

| S.No. | STR locus tested | Genotype Detected |
|-------|------------------|-------------------|
| 1 | D8S1179 | 10,15 |
| 2 | D21S11 | 29,32 |
| 3 | D7S820 | 8,10 |
| 4 | CSFIPO | 10,12 |
| 5 | D3S1358 | 15,16 |
| 6 | TH01 | 7,9 |
| 7 | D13S317 | 8,11 |
| 8 | D16S539 | 10,11 |
| 9 | D2S1338 | 23,23 |
| 10 | D19S433 | 13,14 |
| 11 | vWA | 15,18 |
| 12 | TPOX | 8,12 |
| 13 | D18S51 | 12,14 |
| 14 | D5S818 | 11,12 |
| 15 | FGA | 23,23 |
| 16 | Amelogenin | XY |



தடய அறிவியல் ஆய்வறிக்கை
Forensic Examination Report



தடய அறிவியல் துறை
(குலைமை ஆய்வகம்)

TC-10611

'பாரன்சிக் ஹவுஸ்', 30A, காமராசர் சாலை, மைலாப்பூர், சென்னை-600004

FORENSIC SCIENCES DEPARTMENT
(Main Laboratory)

'Forensic House', 30A, Kamarajar Salai, Mylapore, Chennai-600 004

* ஐந்தெட்டு எழுத்து எண்

ஐந்தெட்டு எழுத்து

* Report No:

T.No.xx/2022 DNA/xx/2022

Dated: 0x.06.2022

இயக்குநர் தடய அறிவியல் துறை, 30A, காமராசர் சாலை, மைலாப்பூர், சென்னை-600 004, அவர்களுக்கு, வழக்கு தொடர்பான நீதிமன்ற விசாரணைகளின் முடிவுகள் அறிவிக்கப்படவேண்டும். (1962 ஆம் ஆண்டு சூலைத் திங்கள் 16 ஆம் நாள்ிட்ட உள் துறை அரசு நிலையாணை எண் 2408 மற்றும் 1968 ஆம் ஆண்டு சூலைத் திங்கள் 29 ஆம் நாள்ிட்ட உள் துறை அரசு நிலையாணை எண் 2158 ஆகியவற்றைக் காண்க.)

The result of the Judicial inquiries into the case should be reported to the Director, Forensic Sciences Department, 30A, Kamarajar Salai, Mylapore, Chennai-600 004, vide G.O. Ms. No. 2408, Home, dated 16th July 1962 and G.O. Ms. No.2158, Home, dated 29th July 1968.

அனுப்புநர்: இயக்குநர் தடய அறிவியல் துறை 'பாரன்சிக் ஹவுஸ்', 30A, காமராசர் சாலை, மைலாப்பூர், சென்னை --600 004.

From: The Director, Forensic Sciences Department, 'Forensic House', 30A, Kamarajar Salai, Mylapore, Chennai-600 004.

ஐந்தெட்டு எழுத்து: Sessions Judge,

To: Special Court for Exclusive Trial of
Cases under POCSO Act,
XXX (FAC),
XXX District.

A paper cover containing the following items was received for DNA analysis on 16.03.2022 through PC 1640 Mr.Xxx xx under correct seals.

Item 1: A white pouch enclosing a blood card with blood stains and marked, "Xxx Cr.No: 196/2021 XXX PS"

Item 2: A white pouch enclosing a blood card with blood stains and marked, "Xxx Cr.No: 196/2021 Xxx PS"

REPORT: DNA was extracted from the above blood samples and amplified for 15 STR loci using PCR amplified STR technique after taking due care for the integrity of each sample. The blood samples were analysed from 07.06.2022 to 17.06.2022 and labelled as (i) Alleged Accused–DNA_xxx_2022_AA_G(ii) Biological Mother–DNA_xxx_2022_BM_S.

The DNA profile of the foetus (of ref 2) was compared with the DNA profiles of alleged accused Mr. Xxx and biological mother Ms.Xxx.

A comprehensive analysis of the test results and the interpretations thereof is given in the enclosed annexure. From the comprehensive analysis of the test results as shown in annexure, the alleged accused Mr.Xxx is not found excluded from the paternity of the foetus (of ref.2) under any of the 15 STR loci tested. Hence the cumulative probability of paternity of Mr.Xxx for being the father of the foetus (of ref 2) and the cumulative chance of exclusion of any random man from the paternity of the foetus (of ref.2) were computed.

- (i) the cumulative probability of paternity of Mr.Xxx for being the father of the foetus (of ref 2) is found to be 99.9999998%.
- (ii) the cumulative chance of exclusion of any random man from the paternity of the foetus (of ref 2) is 99.99999999999999%.

Conclusion: From the DNA typing results of the above samples, it is found that

- (i) the gender of the foetus (of ref 2) is found to be male.
- (ii) Mr. Xxx is the biological father of the foetus (of ref 2).

Note:

1. This report may be used as evidence in any inquiry, trial or other proceedings as per Sec.293 CrPC. If evidence of the scientist is absolutely required as to the subject-matter of this report, summons may kindly be issued to Dr.M.Usha Rani, Scientific Officer well in advance, for depositing evidence.
2. Result relates only to the items examined.
3. Report shall not be reproduced except in full, without the written approval of the Director, Forensic Sciences Department, Chennai.
4. Reference to procedure used: Working Procedure Manual – Forensic DNA, Forensic Sciences Department (Main Laboratory), Chennai-4.

No.DNA/XXX/2022

**Comprehensive Analysis of the test results**

| Sl. No. | STR Locus Tested | Genotype | | | Cumulative probability of paternity of alleged accused Mr.Xxx % | Cumulative chance of exclusion of Random man % |
|---------|------------------|------------------------|---------------------|--------------------------|---|--|
| | | Alleged Accused Mr.Xxx | DNA/XXX/2021 Foetus | Biological Mother Ms.Xxx | | |
| 1 | D8S1179 | 15,17 | 10,15 | 10,10 | 71.94 | 80.50 |
| 2 | D21S11 | 29,29 | 29,32 | 31,2,32 | 93.95 | 98.39 |
| 3 | D7S820 | 10,11 | 8,10 | 8,10 | 97.93 | 99.86 |
| 4 | CSF1PO | 10,11 | 10,12 | 12,12 | 98.97 | 99.96 |
| 5 | D3S1358 | 15,16 | 15,16 | 15,16 | 99.41 | 99.99 |
| 6 | TH01 | 7,9 | 7,9 | 7,9 | 99.73 | 99.999 |
| 7 | D13S317 | 11,12 | 8,11 | 8,10 | 99.88 | 99.9999 |
| 8 | D16S539 | 11,13 | 10,11 | 10,12 | 99.92 | 99.99999 |
| 9 | D2S1338 | 20,23 | 23,23 | 18,23 | 99.98 | 99.9999994 |
| 10 | D19S433 | 13,14 | 13,14 | 14,14 | 99.990 | 99.9999998 |
| 11 | vWA | 15,18 | 15,18 | 15,19 | 99.997 | 99.9999999 |
| 12 | TPOX | 8,12 | 8,12 | 8,8 | 99.999 | 99.999999999 |
| 13 | D18S51 | 12,13 | 12,14 | 14,15 | 99.99999 | 99.99999999999 |
| 14 | D5S818 | 11,12 | 11,12 | 10,11 | 99.9999994 | 99.9999999999999 |
| 15 | FGA | 23,26 | 23,23 | 22,23 | 99.9999998 | 99.99999999999999 |

Note: The numbers given under genotype represent the nomenclature of alleles under the locus

No.DNA/XXX/2022

Inference: In a child, under each of the STR locus, one allele should be contributed by the biological mother (maternal) and the other allele should be contributed by the biological father (paternal).

1. Of the two alleles under each of the 15 STR loci found in the foetus (of ref 2), one allele (maternal) was contributed by the biological mother Ms.Xxx and hence the other allele (paternal) is ought to have been contributed by the father to this foetus (of ref 2).
2. All such paternal alleles which ought to have been contributed by the father to this foetus (of ref 2) are found to be present in the alleged accused Mr.Xxx.
3. Apart from the alleles accounted as present either in the biological mother Ms.Xxx or in the alleged accused Mr.Xxx, no other unaccounted allele is present in the foetus (of ref 2).
4. Since the alleged accused Mr.Xxx is not found excluded from the paternity of the foetus (of ref 2) under any of the 15 STR loci tested, his probability of paternity has been computed.
5. The cumulative probability of paternity of the alleged accused Mr.Xxx for being the father of the foetus (of ref 2) is 99.9999998%.
6. The cumulative chance of exclusion of any random man from the paternity of the foetus (of ref 2) is 99.99999999999999%.

(Dr.N.Mahalakshmi, M.Sc., Ph.D.,)
Asst. Chemical Examiner to Govt. &
Deputy Director

(Dr.M.Usha Rani, M.Sc., M.Phil., Ph.D., PGDCFS)
Scientific Officer



FORENSIC SCIENCE LABORATORY, HARYANA, MADHUBAN- KARNAL
(An ISO/IEC 17025 Accredited Laboratory)

DNA FINGERPRINTING WORKSHEET: DNA DIVISION

FILE NO. _____ NO. OF Parcel(s)/Item(s) _____ DATED _____ The parcels/items have been opened verified and found to be as per the Letter of Advice. Specific Information relevant for examination as per LOA/requisition of IO for _____.

ANALYTICAL PLAN:

Routine SSO : **Siddharth Kaushik**

I. ISOLATION/ORGANIC EXTRACTION

Pre processing:
 Phenol-Chloroform Extraction:
 DNA precipitation

II. QUANTIFICATION OF DNA

| | | | | | | | |
|------------------------------|--|--|--|--|--|--|--|
| DNA source, Item No: | | | | | | | |
| Readings at 260 nm: | | | | | | | |
| Readings at 280 nm | | | | | | | |
| Ratio at 260/280 | | | | | | | |
| Quantity of DNA ng / μ l | | | | | | | |
| Vial No | | | | | | | |

III. QUALITY CHECK:

| | |
|----------------------------|--------------------------|
| Electrophoresis: | Mini gel Electrophoresis |
| Size of Gel- | 0.3 mm |
| Agarose %- | 0.8% |
| No. of DNA samples loaded: | _____ |
| Amount of sample loaded: | 10µl |
| Electrophoresis condition: | _____ |
| Buffer Current/Voltage- | 40V, 220Amp., 1 Hr. |

IV. PURIFICATION

Kit used: 30 K

Column used: Nanocep

Sample No.: _____

V. PCR AMPLIFICATION

Sample Vial No.: _____

Sample quantity: _____

Primers used

1. Forward primer
2. Reverse primer : _____ primer set

Condition maintained:

No. of Cycles run: _____ cycles

Amplicon Vial No. _____

VI. STR ANALYSIS ON ABI 3130/3500 GENTIC ANALYZER

Type of kit used: _____ Kit

Sample no. : _____

Number of samples loaded: _____ Run No _____

Number of loci studied: _____

Electrophoregram: Enclosed

Profile Chart: Enclosed

Conclusion: _____

FORENSIC SCIENCE LABORATORY, __

FSL (H) No.-: 15/DNA-_____, DNA-_____

Allele Chart

| Sr. No. | IDENTIFIER LOCUS/MARKER | ITEM NO.1(Baby) (corresponding allele) | TEM NO.2(Mother) (corresponding allele) | TEM NO.3(Father) (corresponding allele) |
|---------|----------------------------|--|---|---|
| 1. | D8S1179 | 11,14 | 14,15 | 11,13 |
| 2. | D21S11 | 30,32.2 | 30,32.2 | 29,32.2 |
| 3. | D7S820 | 8,10 | 8,9 | 10,11 |
| 4. | CSF1PO | 11 | 11,12 | 11 |
| 5. | D3S1358 | 15,16 | 16 | 15,16 |
| 6. | TH01 | 8,9 | 8,9 | 6,9 |
| 7. | D13S317 | 8,9 | 9,12 | 8 |
| 8. | D16S539 | 9,11 | 11 | 9 |
| 9. | D2S1338 | 18,19 | 19,24 | 18,19 |
| 10. | D19S433 | 14,15 | 13,15 | 13,2,14 |
| 11. | vWA | 16,18 | 17,18 | 16,19 |
| 12. | TPOX | 8,10 | 10,11 | 8 |
| 13. | D18S51 | 12,14 | 12,16 | 14 |
| 14. | AMELOGENIN | X | X | X,Y |
| 15. | D5S818 | 12,13 | 11,13 | 11,12 |
| 16. | FGA | 22 | 21,22 | 22,22.2 |

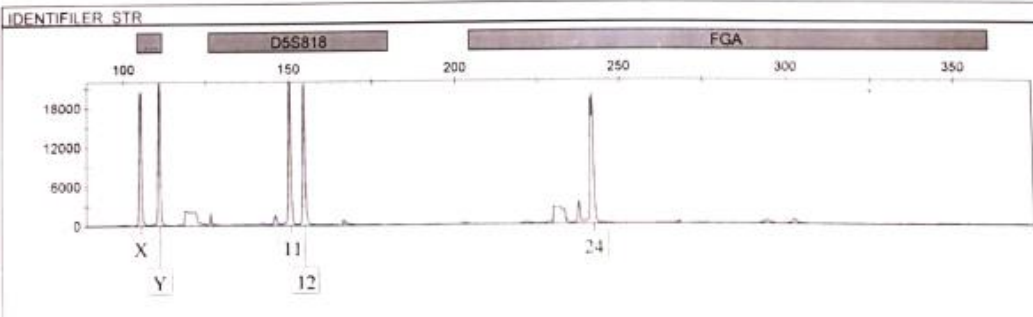
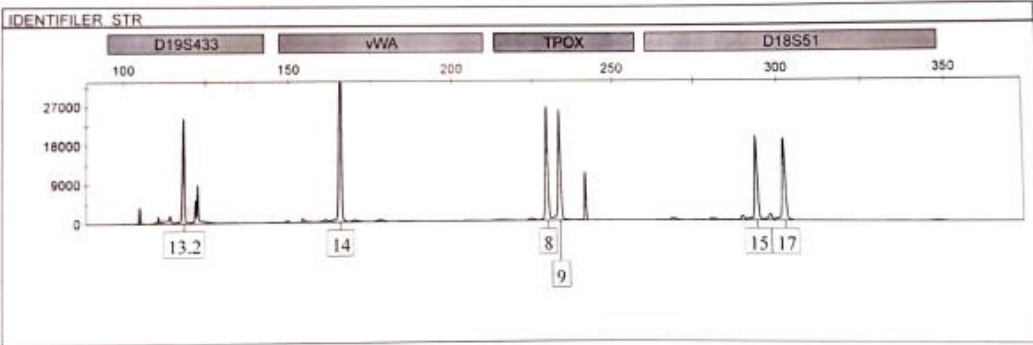
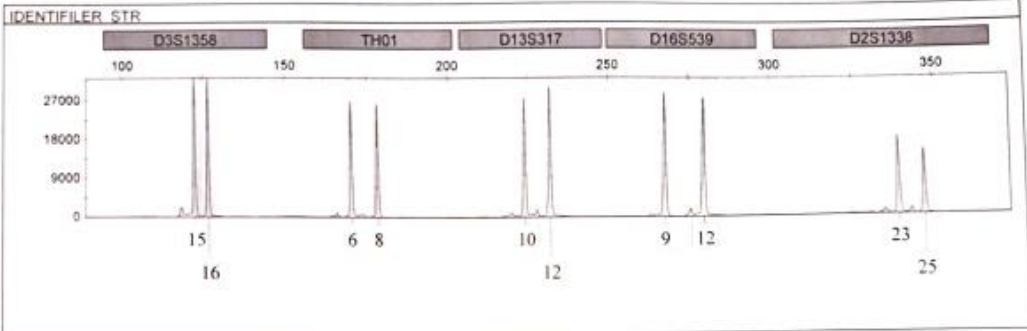
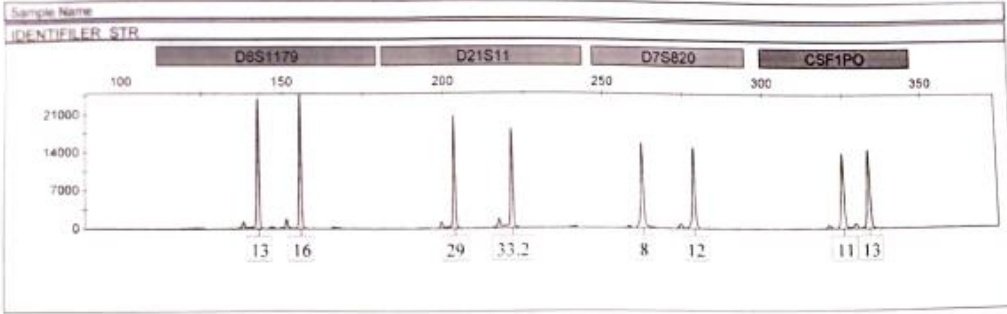

Annexure-III

**FORENSIC SCIENCE LABORATORY, HARYANA,
MADHUBAN-KARNAL**

(An ISO/IEC 17025 Accredited Laboratory)

IDENTIFICATION/AUTHENTICATION FORM

1. Name _____ Occupation _____
2. Visible Identification Mark _____
3. Father's/Guardian's/Husband's Name _____
4. Age _____
5. In case of Missing identity
(Relation with the deceased) _____
6. Gender (Tick appropriate) Male Female
7. Caste & Origin of State _____
8. Address _____
_____ Pin _____
9. Visible Genetic Abnormality (if any) _____
10. Date of sample collection _____
11. Case FIR no./PMR/MLR no. & date _____
12. Honorable court/Police Station _____

Affix recent
Photo

Duly
Attested

Do not staple

DECLARATION BY DONOR/GUARDIAN

I _____ son/daughter/wife/under guardian of _____ hereby declare that the blood/sample is given with my consent to FSL, Haryana, for DNA fingerprinting. The blood is mine/is of my child and I/Child did not receive a blood transfusion / bone marrow transplant within last three months.

(Thumb impression of the donor)



Signature Donor/Guardian

_____ ml of blood sample is collected in the presence of the following witness:

Witness 1

1. Name _____
2. Signature _____
3. Address _____

Witness 2

1. Name _____
2. Signature _____
3. Address _____

The content of this form was read and explained to the donor/party in the language which the donor/party understands and thus fully understood the content of it.

Sample collected by:

Name _____
Signature _____
Date: _____ Time: _____
Address _____

Investigating Officer representative:

Name, Number & Rank _____
Signature _____
Date: _____ Time: _____

Note: Case FIR no. /PMR/MLR no. and details of the donor should be clearly mentioned on the EDTA vials, the vial should be sealed properly & the seal should be duly attested. The sample should be transported immediately to the laboratory in thermal box and box stuffed with coolant pack or ice.

For office use only

FSL (H) file No. : _____

Forensic Science Laboratory, XXXXXX, XXXXXX
(XXXXXX)

Worksheet for Serological examination of Blood/Semen

Case No. _____

Date work started _____

Date work finished _____

| Sr. No | Name of the Exhibit | Area | A.B.O | Grouping | | Result |
|--------|---------------------|------|--------------------|--------------------|--------------------|--------|
| | | | Anti-A and A Cells | Anti-B and B Cells | Anti-H and O Cells | |
| | | | | | | |

S.A./S.S.A.

A.D./S.S.O

Forensic Science Laboratory, XXXXXX, XXXXXX
(XXXXXX)

Serology Division
Worksheet Identification of Species of Origin

Case No. _____

Date work started _____

Date work finished _____

| Exhibit No. | Name of Exhibit | Anti-Human | Anti-Cow | Anti-Buffalo | Anti-Dog | Anti-Sheep | Anti-Fowl | Anti-Pig | Results |
|-------------|-----------------|------------|----------|--------------|----------|------------|-----------|----------|---------|
| | | | | | | | | | |

S.A./S.S.A.

D.D./A.D./S.S.O

FORENSIC SCIENCE LABORATORY, XXXXXXXXXXXX
 XXXXXXXX, XXXXXXXX

REPORT (OPINION) FSL No. _____ DATED _____

Accredited By
 National Accreditation Board for Testing & Calibration Laboratories

1- Please quote the Report (Opinion) No. & Date in case of any further correspondence or summons.
 2- Reports shall not be reproduced except in full, without the written approval of the Director.

To

Your forwarding memo No. _____ dated _____ regarding
 _____ sealed/unsealed parcel(s) in connection with FIR/Enquiry No.
 _____ Dated _____ U/S _____ P.S. _____
 stated by you to have been dispatched vide R.C. No. _____ dated _____ through
 _____ and received in this division on _____.

Description of parcel (s) and condition of seal (s)

Description of article (s) contained in parcel (s)

| Parcel No. | No. & seal impression | Description of parcel (s) |
|------------|-----------------------|---------------------------|
| | | |

Laboratory Examination

Date of Performance:

| Test Parameters | Test Performed | Test Methods | Findings | Inference |
|-----------------|----------------|--------------|----------|-----------|
| | | | | |

OPINION :

ENCLS :

NOTES : i). After examination the exhibits/parcels has/have been sealed with seal of...
 ii). The result relates only to the items tested above.

Authorized signatory
 (Signature with stamp)

Questions frequently asked by court

- Whether, the brothers or the male persons of the same family will get the same DNA profile?

Ans: Two individuals other than the identical twins will not have the same DNA profile.

- By appearance, a child looks like the father. But excluded How?

Ans: Paternity is established by scientific means, only by determining the 50 – 50 contribution of genetic markers/ DNA from biological parents to child,

- Have you witnessed the collection of blood?

Ans: No. We receive the blood sample through court

5. Have you seen the victim girl, or the Alleged Accused or the child whose paternity is under question in person?

Ans: No.

6. How long can the Biological specimens forwarded and preserved in division can give positive DNA profile.

- Ans: depends upon the nature of preservation

- . Whether the chain of custody is properly maintained?

Ans: Yes

- . Why there is a time lapse between receipt, analysis and despatch?

Ans: Due to heavy receipt and pending cases

- Whether the instruments used for analysis are properly validated and calibrated?

Ans: Yes

- . Whether the case articles was examined by the same analyst through out the examination?

Ans: No. It is team work

- You are not giving blood groups of the persons concerned why?

Ans: DNA typing is based on alleles

WHAT AN INVESTIGATOR
SHOULD KNOW ?

- **APPROPRIATE** biological specimen in **ADEQUATE** amount
- Transport with **PROPER PRESERVATION** to avoid decomposition
- **RELEVANT CONTROL SAMPLES** –essential of comparison of two samples in DNA profiling
- **AUTHENTIC** sample- **TAMPER PROOF**- during transit to lab

WHAT A MEDICO-LEGAL EXAMINER SHOULD KNOW ?

- Ensure collected samples has ADEQUATE number of cells to yield High-Molecular wt. DNA
- Sexual assault cases – unless semen/sperm not in swab – DNA test is not possible
- Murder case – tissue of mutilated body
- Appropriate control samples for comparison
- Avoid contamination
- Quality assurance/ Quality control norms

WHAT A JUDICIAL FRATERNITY SHOULD KNOW ?

- **Chain of Custody of Evidence**
- **No Tampering Of Questioned Samples**
- **Test Conducted As Per **International Standard****
- **Exclusion/inclusion **Probability** is Enclosed in Report**

- Result of the examination of each sample analysed and the necessary comparison of samples carried in the test.
- Which samples were taken for examination & Why the other samples were not taken for examination
- **Probability of match in case of rape cases** .Paternity index in case of paternity cases
- The report should contain the definite opinion about the result of the examination like, whether the accused /suspect is excluded or cannot be excluded.
- Finally, the list of enclosures attached to the report viz., **electropherograms**, allelic data if any.

Forensic Report

- Result of the examination of each sample analysed and the necessary comparison of samples carried in the test.
- Which samples were taken for examination & Why the other samples were not taken for examination
- **Probability of match in case of rape cases** .Paternity index in case of paternity cases
- The report should contain the definite opinion about the result of the examination like, whether the accused /suspect is excluded or cannot be excluded.
- Finally, the list of enclosures attached to the report viz., **electropherograms**, allelic data if any.

On Chain of Custody

- When your laboratory received the case for DNA testing?
- How was the condition of samples whether sealed or not?
- Describe the chain of custody in your laboratory?
- How samples are stored while awaiting examination?
- How the samples are stored during examination?
- Was the entire sample used during the testing process?
- What were results in this case?
- Do you think that the reported results are correct?

Guidelines to be followed during collection and preservation of samples for DNA analysis

| Sl. No. | Type | Sample or Material to be sent for analysis | Precautions | Purpose of DNA analysis |
|---------|---|--|---|---|
| 1. | Unidentified body – Fresh –Not Decomposed | Blood | To be collected in sterile gauze cloth and air dried. Liquid blood should NOT be sent. | To identify the body- by comparison with DNA profile of parents or spouse and child |
| | | Tissues | Preserved in saline | |
| 2. | Unidentified body – Fresh –Not Decomposed | Femur Bone or any long bone (of legs or arms) | Dry bone: Wrapped in paper. Bone with adhering tissue: Preserved in common salt. Whole limb should not be sent | |
| | | In the absence of femur or long bone: Any bone | -do- | |

Guidelines to be followed during collection and preservation of samples for DNA analysis

| Sl. No. | Type | Sample or Material to be sent for analysis | Precautions | Purpose of DNA analysis |
|---------|----------------------------------|---|--|---|
| 3. | Skeletal remains | Femur bone or any long bone | Dry bone: Wrapped in paper. Bone with adhering tissue: Preserved in common salt. Whole limb should not be sent | To identify the body- by comparison with DNA profile of parents or spouse and child |
| | | In the absence of femur or long bone, any other bone. | -do- | |
| | | Molar teeth | Packed in a vial | |
| 4. | Unidentified body - Burnt | Partially burnt bones | -do- | |

Guidelines to be followed during collection and preservation of samples for DNA analysis

| Sl. No. | Type | Sample or Material to be sent for analysis | Precautions | Purpose of DNA analysis |
|---------|--|--|--|---|
| 5. | Unidentified body – Completely burnt bones, charred remains | Nil | Unsuitable for DNA analysis (Kindly do not forward the item) | To identify the body- by comparison with DNA profile of parents or spouse and child |
| 6. | Unidentified body – Where none of the materials mentioned above are available | Hair with root | Packed in a vial | |

Guidelines to be followed during collection and preservation of samples for DNA analysis

| Sl. No. | Type | Sample or Material to be sent for analysis | Precautions | Purpose of DNA analysis |
|---------|-----------------------------|--|---|--|
| 7. | Sexual assault cases | <p>1. Clothings/Articles stained with blood or other body fluids.</p> <p>2. Vaginal smear/Swab – to be collected by Medical Officer.</p> | <p>Wrapped in paper after drying</p> <p>Smear – collected on glass slide, dried and kept in a paper cover</p> <p>Swab:- Kept in a sterile test tube after air drying.</p> | <p>To fix the culprit by comparing with the DNA profile of suspect</p> |
| 8. | Murder cases | Clothing/Articles stained with blood or other body fluids | Wrapped in paper after drying | -do- |

Guidelines to be followed during collection and preservation of samples for DNA analysis

| Sl. No. | Type | Sample or Material to be sent for analysis | Precautions | Purpose of DNA analysis |
|---------|---------------------------------|---|--|---|
| 9. | Scene of crime | 1. Blood stained articles 2. Articles with semen stains 3. Salivary stained items (Cigarette, beedi butt etc.) 4. Hair with root | Wrapped in paper after air drying. Packed in a vial | To identify the culprit- By comparing with DNA profile of any suspect |
| 10. | Suspect in rape or murder cases | Clothings/Articles stained with blood or other body fluids | Wrapped in paper after air drying. | -do- |

Guidelines to be followed during collection and preservation of samples for DNA analysis

| Sl. No. | Type | Sample or Material to be sent for analysis | Precautions | Purpose of DNA analysis |
|---------|---|--|---|--|
| 11. | Suspect – to compare with body fluids or tissue etc found at SOC or on victims. | Blood | To be collected on FTA card provided by Forensic Sciences Department through Courts | To fix the culprit by comparing with the DNA of body fluids or tissue etc found at SOC or victims. |
| 12. | Parents or spouse and child | Blood | -do- | To fix the identity of an unidentified body- By comparing with DNA material collected from body. |

| Do's | Don'ts |
|--|---|
| To establish identity of deceased from skeletal remains, always collect intact long bones (femur, humerus)/molar teeth in duplicate | Never prefer to collect the clavicle bone. |
| Preserve tissue, fetus and other similar samples in 0.9% DNS and keep it in refrigerator for a short period if there is any delay in completing legal formalities for forwarding the sample to the laboratory. | Never use formalin to preserve tissues and bones. |
| Liquid blood with EDTA in sterile vials and container having tissue, fetus and other similar samples should be kept in thermos flask/ thermocol box stuffed with ice/coolant packs. | |
| Always wrap stained clothes and fabrics in paper sheet after completely drying and pack in cotton cloth or aerated container. | Do not pack clothes/garments, stains and swab in wet condition. |
| If there is more than one sample pack them separately. | Never dry stains, swabs in direct sunlight, by use of heater, hot air blower etc. |
| From dead body always take two or more types of samples in duplicate. | Do not send completely burnt/broken bones, burnt or singed hairs. |
| Always use paper bag as packing material for biological evidence. | Never use polythene bag as packing material for biological evidence. |



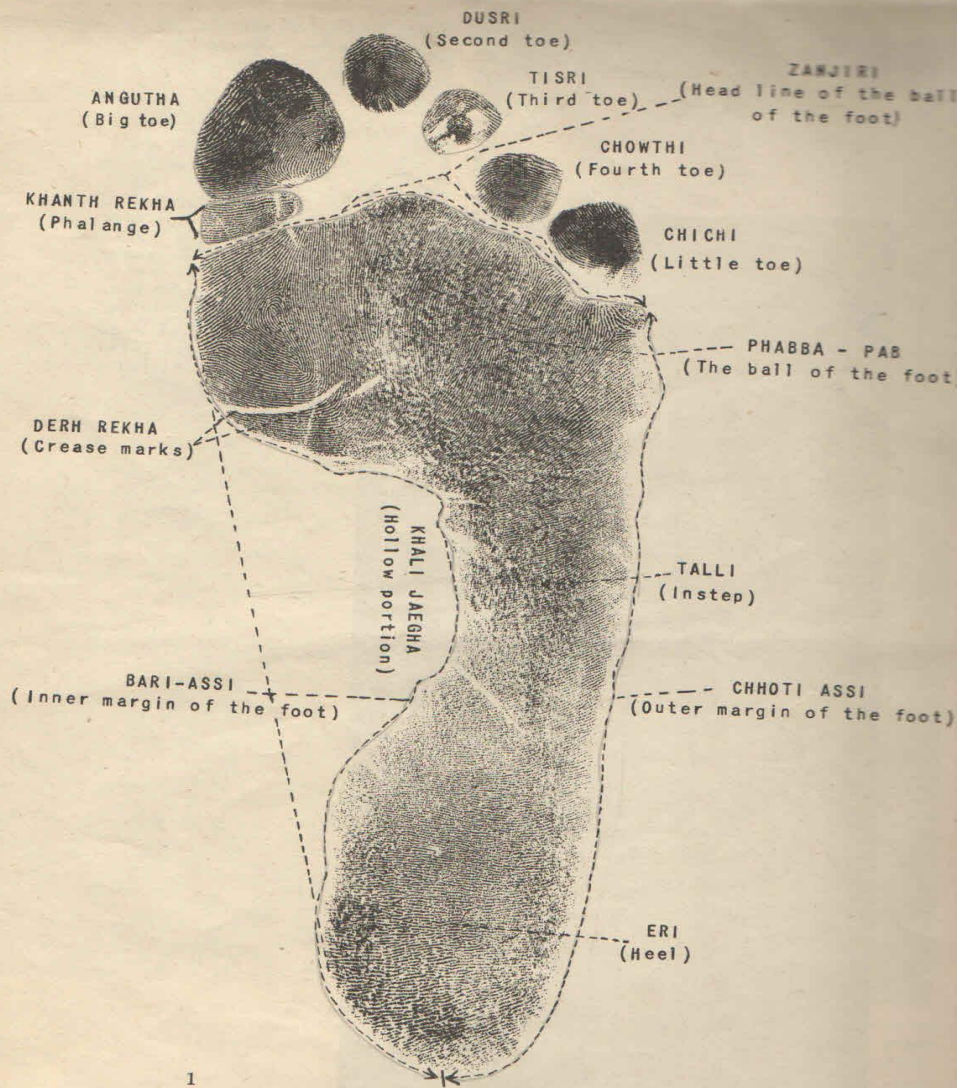

1
 A surface footprint taken with printers' ink.
 The different parts have been shown with the
 terms used by trackers. Their English equi-
 valents have been given in brackets.

Foot Print

- One of the valuable physical evidence left by criminal unintentionally at a crime scene .
- Analysis of footprints can provide useful information to establish personal identity and ease the crime investigation

- Footprint is similar to finger print in their uniqueness.
- Both have individual characteristics that are capable of proving positive identification.
- Like finger prints, no two people have the same palm print or footprint.

- According to Dr. Michael Nirenberg, a forensic podiatrist **footprint tells more than a fingerprint.**
- The detailed analysis of the characteristics like **phalange marks**, feature of toes, **humps**, crease marks, **flatfoot condition**, pits, **corns**, and crack marks can be used as valuable evidence to link the crime and the perpetrators.

Examination of footprint helps in the estimation of:

- stature, weight, sex,
- number of individuals present,
- direction in which individual was moving,
- speed at which he was moving and whether carrying anything heavy weight

- **Footprints and stride length can be used to estimate height of the person .**

$$\begin{aligned} \text{Height} &= 6.7x \text{ foot length} \\ &= 2.5x \text{ stride length} \end{aligned}$$

Case Laws

- Rejecting the contention that the study of footprints is not a science in *Din Muhammad v Emperor*, Central Provinces Police Gazette dated 27th May, 1914 pp. 125-130, the court of the Judicial Commissioner at Nagpur (H.J. Stanyon and H.F. Hallifax, A.J. Cs) as far back as in 1914 held:

“The knowledge of footprints has similarly been systematized and pursued by trackers, mainly uncivilized and ignorant people in all other respects, all over the world. The matter is therefore undoubtedly a science and the opinion of a person specially skilled in it is a relevant fact, under Sec-45 of the Evidence Act “

In the case of *Pritam Singh v State of Punjab* (AIR 1956 S.C. 415) there is an observation to the effect that the science of identification by footprints is a rudimentary science and much reliance cannot be placed on the result of such identification.

VIKRAM SINGH *versus* STATE OF HARYANA

High Court of Punjab and Haryana, Chandigarh

DATE OF DECISION: 26.5.2006

- The defence side has also examined 8 defence witnesses to counter the prosecution case. The prosecution witnesses so examined was Dr.K.P.S.Kushwaha (PW2), FSL, Madhuban, Karnal. He inspected the scene of occurrence in the presence of the Investigating Officer in the intervening night of 20/21.2.1996.

- Thirdly, the conviction of the appellants was based only on circumstantial evidence.
- One of such circumstances is the foot prints noticed on a leather bag allegedly found lying at the spot by Dr.K.P.S.Kushwaha (PW2).
- The impressions were faint and partial.
- Though the bag was picked up and taken to the laboratory but it was not duly sealed at the spot, nor was a seizure memo in respect thereof prepared, nor a witness to the seizure was cited.
- The bag was returned to the police station unsealed on 23.2.1996.

- The bag was then sent to Dr.S.K.Nagpal (PW4), who, later on, submitted his Crl.Appeal No.364-DB of 1998 18
- report (Ex.PJ) and concluded that the foot prints found on the bag could be that of shoes allegedly recovered from the accused-appellants at the time of their arrest.
- According to learned counsel, the opinion as such does not appear to be conclusive in nature and was of no use to the prosecution.

- Thus, there was a clear planning and motive to commit the offence.
- As argued by learned counsel for the complainant, this circumstance finds support from the observations of Hon'ble the Apex Court in the judgment reported in 1972 Cr.L.J. 7 (Udhaipal Singh versus State of U.P.), which on reproduction, read as under:-

- As regards the scientific evidence with regard to the trespassing into House No.F-2, the scientists from Forensic Science Laboratory, Madhuban, were immediately called through ratio message. They inspected the scene of occurrence and collected scientific evidence.
- Dr.K.P.S.Kushwaha (PW2),FSL, Madhuban, noticed faint and partial shoe impressions on the floor towards the head of the dead body vide photograph (P13). Its negative is Ex.P14.
- He also noticed a trail of blood showing that the body was dragged out of the drawing room after inflicting the injuries. This is shown in the photographs (Exs.P-15 and P-Crl.Appeal No.364-DB of 1998 25

- Thus, there was no chance of tampering with and padding out by the Investigating Officer.
- Tracings and the foot prints collected during the intervening night of 20/21.2.1996, tallied with the shoes taken into possession on the arrest of accused-appellants Vikram Singh and Surender Singh on 1.3.1996.
- Photographer, Ram Niwas (PW33) also proved the photographs taken by him. Dr.Hans Raj Aggarwal (PW3), Assistant Director, FSL, Madhuban, made trial cuts on the maxi (Ex.P1) of deceased, Smt. Usha Kundu, with the weapons recovered from accused Vikram Singh (knife-Ex.P6) and Surender Singh (kirpan-Ex.P5).
- Trial cuts were compared with the crime cuts and after microscopic examination, it was found that these two weapons had been used in the commission of offence.

- "In cases where only circumstantial evidence is available at the outset, one normally starts looking for motive and opportunity to commit the crime.
- If the evidence shows that the accused have a strong enough motive, had the opportunity of committing the crime and the established circumstances on the record considered along with explanation, if any, of the accused exclude reasonable possibility of anyone else being the real culprits then the chain of evidence can be considered to be so complete so as to show that within all probabilities, the crime must have been committed by the accused and he may be held guilty."

- Moreover, in judgment reported in AIR 1997 SC 2960 (Mohammad Aman etc. versus State of Rajasthan), Hon'ble the Apex Court has held that foot prints identification is not a fully developed science but it can be used to reinforce other evidence.
- In the present case, there is nothing to discard the foot prints because it was directly taken by the Scientists of the FSL, Madhuban, from the scene of occurrence and there was absolutely no scope for its being tempered with. Thus, the identity of the accused persons also stands established.

Answers to Questions

- Yes , it is a complete science
- It is definite science , if properly understood, collected & evaluated. It is covered under Sec.45 of Indian Evidence Act.
- It is not rudimentary / under developed science.
- It can be put at a level with ballistics and fingerprint examination (J.R. Abbot (1964), Footwear Evidence (page 8), Charles C Thomas Illionois ,U.S.A

Wildlife forensics - **Types of evidence analyzed**

- Any part of an animal including **blood**, tissue samples, hair, teeth, bones, claws, tusks, hides, fur, feathers, or stomach contents - poisons, pesticides, and weapons.
- Products made from animals , parts and products of plants.
- Footprints, tire/Pug marks , fingerprints

Hair : Identification of Species

- Hair characteristics-
Cutical, Medulla, Cross-Section using Light Microscopy and SEM help in Identification of species

Hair- Identification of Species

- Hair-made up of dead cells which do not change in appearance once extruded from the skin.
- Hence, hairs retain their structure and appearance even when detached from animal pelt.
- Comparison of unknown samples with known forms the basis of hair analysis.
- Hair characteristics- Cutical, Medulla, Cross-Section using Light Microscopy and SEM help in Identification of species

Hair: Identification of Species

- Electrophoresis Techniques – SDS-PAGE and IEF
- Keratin Protein Pattern have been used to differentiate Pashmina, Shahtoosh, Angora, Brown Bear, Black Bear, Sloth Bear, Wild Boar etc.
- Applicable to other species also

Bone : Identification of Species

- Whether material is bone or not ?
- If it is bone, is it human or nonhuman
- If nonhuman – Identification of species.
- Human and nonhuman mammals have same skeletal characteristics like number and types of bones

- Bone structure in most mammals is similar
- Large mammal bones e.g. Bear, Deer, Large Dogs and pigs are often confused with adult human bones
- Small animal bones may be confused with juvenile or fetal bone.

- Pelvis of small mammals can be confused with human or fetal pelvis.
- If small pelvis is fused into one unit, it will be a nonhuman pelvis.
- Human juvenile pelvis is in multiple pieces.
- The two adult pelvic bones do not fuse at all unless there is some pathological condition.

Bear Bile : Identification of Species

- Thin Layer Chromatography (TLC)
- High Performance Thin Layer Chromatography (HPTLC)
- Highly accurate and reproducible results

Pug Marks – Identification of Species

- Pug mark refers to footprint of most animal especially mega fauna.
- Every individual animal species has a distinct pugmark, hence used for identification.
- Pug marks also help in determination of sex, age and physical condition of an animal.

Pug Marks – Collection

- Photography
- Tracing
- Plaster Casts

Species identification

- **Physical inspection/morphological examination** - From a whole specimen, or even only parts of an animal or plant it may be possible to identify the species.
- **Serological method**- Using species specific anti-sera
 - a) Precipitin technique
 - b) Cross-over Electrophoresis
 - c) Elisa Method
- **Keratin Protein pattern analysis** -using Electrophoretic and Iso Electrophoretic techniques

DNA analysis

- When the evidence cannot be identified by conventional techniques, DNA can be analyzed to identify the species.
- Specific regions of DNA that show variation among species but are generally conserved within species are targeted.
- These regions of DNA are sequenced from the specimen, and compared to a validated reference database of known species.
- The level of similarity between the specimen and reference sequences enables the identification of species of origin.

Identification of geographic origin

- This may be important for species which are protected by varying legislation across their range,
- i.e ivory from African Elephants is listed under CITES Appendix I everywhere **except in Botswana, Namibia, South Africa and Zimbabwe where it is listed under CITES Appendix II** .
- Two possible methods can be employed.
 - a. Stable isotope analysis**
 - b. DNA analysis**

- Profiles from different environments will vary due to a number of physical, geological and biological factor
- These factors may correspond to different geographic localities and therefore these profiles can be used to infer the geographical origin of a sample.

Aging of samples-Radiocarbon dating:

- for ageing samples based on levels of carbon isotopes following the start of atmospheric nuclear bomb tests.
- The technique can be applied to discriminate specimens that were alive before and after the 1947 convention cut off.

- In some wildlife crime investigations it is necessary to know the age of a sample.
- For example, if a rhino horn was collected prior to 1947, then it pre-dates laws prohibiting trade in rhino horn.
- In order to determine whether the rhino horn was legally collected prior to 1947, a form of stable isotope analysis known as radio carbon dating can be employed

- During the early part of the 1950's atmospheric nuclear weapons testing became common and had the effect of artificially increasing the amounts of different isotopes of the element carbon, particularly the normally rare carbon 14 (^{14}C) which had doubled in abundance by 1965.
- As such, rhino horn that pre-dates this period will be expected to have a lower ratio of ^{14}C than more modern specimens.

Animal sexing

- Where the open and closed hunting season vary between males and females (e.g. deer) it is often necessary to know the gender of a specimen to determine whether an animal was legally killed.
- If a carcass has been prepared for sale, morphological differences between males and females are often no longer present (e.g. antlers or genitalia).
- DNA analysis can, however, determine the gender of the specimen.

Parentage analysis (captive breeding verification)

- The patterns of inheritance from parent to offspring allow **DNA profiles** to be used to verify family relationships.
- The genetic variants present in the DNA profile of an individual must be represented in its putative parents.
- If genetic variants are observed in an individual that do not match those found in the putative parents, then the possibility of the individual being their offspring can be excluded

- This method of parentage analysis has been used successfully on many occasions to challenge the captive breeding claims of people illegally laundering wild taken birds of prey.
- Tests are available for a number of birds of prey and other species..

Toxicology analysis

- Presence of pesticide residues in a variety of animal tissues including gut contents, vomit, feces, blood, urine, liver, kidney and lungs, as well as in poisoned bait.
- Pesticide analysis is a proven method of identifying deaths caused by poisoning or identifying pesticides held by suspects or finding traces in syringes, vehicles or other relevant items

Forensic Veterinary Pathology

- To determine whether the death or injury of an animal was caused by human activity or due to natural influences.
- **Radiographs** are a useful method to determine internal trauma such as broken bones or bullets. Samples (blood/tissue) may be sent for further analysis.
- Forensic veterinary pathology is particularly useful in cases where illegal killings have involved shooting, snaring, trapping, starvation, poisoning, drowning etc.

Taxidermy

- Taxidermy involves preparing, preserving and mounting the skins of deceased animals to replicate their lifelike state.
- It may be possible to determine the likely cause of death even once the specimen has been mounted.
- Taxidermist can reveal external traumas such as bullet wounds or feathers damaged by the passage of shot.
- Some of the larger bones and the skull may be left inside a prepared taxidermy specimen to help support the internal structure.
- **Radiographs** can be used to determine internal traumas.

- It is possible to estimate the age of a specimen.
- Materials used in modern taxidermy such as enamel and acrylic eyes, nylon thread and foam bodies can all be used to estimate a date.
- Birds of prey with full crops may also be indicative that the bird has been poisoned.

Soil characteristic analysis / Diatoms/microbes

- Soil evidence at a crime scene can be used to link a suspect with an offence.
- Soil is comprised of a mixture of organic, mineral and/or synthetic components and is considered as trace evidence.
- As the ratios of these components can vary over a very small area it is possible to profile the characteristics of the soil at the crime scene and compare this with a soil sample found on a person's clothes, shoes, tools or vehicle.

- This is done by comparing the soil colour, particle size and shape, mineralogical composition and biological components.
- **Reflected light microscopes** can be used to compare the particle size and shape and **x-ray diffraction** can be used to compare mineralogical and biological composition.
- Soil analysis can be useful in cases where small amounts of soil have been found on a spade thought to be involved in a badger digging incident or in the tread of a shoe of a suspected egg collector where the raided nest location is known.

Timber Identification

- Species identification from timber is usually possible using morphological, histological genetic analysis.
- Identification of treated wood products depends on the ability to recover DNA from the sample.
- Samples can also be aged with respect to being pre- or post- 1947, using radiocarbon dating (non-genetic technique).

A close-up photograph of a bouquet of daisies in various colors including yellow, pink, red, and magenta. A white card with the words "Thank You" written in a black cursive font is tucked into the flowers. The background is softly blurred, showing more of the bouquet and green foliage.

Thank You